



DESIGN STANDARDS FOR: CONSTRUCTION WASTE MANAGEMENT

The following specifications shall be incorporated into the Project Manual:

WWW.CAMPHANDBOOKS.COM

Description and Purpose

Prevent or reduce the discharge of pollutants to stormwater from concrete waste by conducting washout offsite, performing onsite washout in a designated area, and training employee and subcontractors.

Suitable Applications

Concrete waste management procedures and practices are implemented on construction projects where:

- Concrete is used as a construction material or where concrete dust and debris result from demolition activities
- Slurries containing portland cement concrete (PCC) or asphalt concrete (AC) are generated, such as from saw cutting, coring, grinding, grooving, and hydro-concrete demolition
- Concrete trucks and other concrete-coated equipment are washed onsite
- Mortar-mixing stations exist
- See also NS-8, Vehicle and Equipment Cleaning

Limitations

Offsite washout of concrete wastes may not always be possible.

Objectives

- **EC** Erosion Control
- **SE** Sediment Control
- **TC** Tracking Control
- **WE** Wind Erosion Control
- **NS** Non-Stormwater Management Control
- **WM** Waste Management and Materials Pollution Control

Potential Alternatives

None

Implementation

The following steps will help reduce stormwater pollution from concrete wastes:

1. Discuss the concrete management techniques described in this BMP (such as handling of

2. concrete waste and washout) with the ready-mix concrete supplier before any deliveries are made.
3. Incorporate requirements for concrete waste management into material supplier and subcontractor agreements.
4. Store dry and wet materials under cover, away from drainage areas.
5. Avoid mixing excess amounts of fresh concrete.
6. Perform washout of concrete trucks offsite or in designated areas only.
7. Do not wash out concrete trucks into storm drains, open ditches, streets, or streams.
8. Do not allow excess concrete to be dumped onsite, except in designated areas.
9. For onsite washout:
 - a. Locate washout area at least 50 feet from storm drains, open ditches, or water bodies.
 - b. Do not allow runoff from this area by constructing a temporary pit or bermed area large
 - c. enough for liquid and solid waste.
 - d. Wash out wastes into the temporary pit where the concrete can set, be broken up, and
 - e. then disposed properly.
10. Avoid creating runoff by draining water to a bermed or level area when washing concrete to remove fine particles and expose the aggregate.
11. Do not wash sweepings from exposed aggregate concrete into the street or storm drain.
12. Collect and return sweepings to aggregate base stockpile or dispose in the trash.

Education

1. Educate employees, subcontractors, and suppliers on the concrete waste management techniques described herein.
2. Arrange for contractor's superintendent or representative to oversee and enforce concrete waste management procedures.

Concrete Slurry Wastes

1. PCC and AC waste should not be allowed to enter storm drains or watercourses.
2. PCC and AC waste should be collected and disposed of or placed in a temporary concrete washout facility.
3. A sign should be installed adjacent to each temporary concrete washout facility to inform concrete equipment operators to utilize the proper facilities.
4. Below grade concrete washout facilities are typical. Above grade facilities are used if excavation is not practical.
5. A foreman or construction supervisor should monitor onsite concrete working tasks, such as saw cutting, coring, grinding and grooving to ensure proper methods are implemented.
6. Saw-cut PCC slurry should not be allowed to enter storm drains or watercourses. Residue from grinding operations should be picked up by means of a vacuum attachment to the grinding machine. Saw cutting residue should not be allowed to flow across the pavement and should not be left on the surface of the pavement. See also NS-3, Paving and Grinding Operations; and WM-10, Liquid Waste Management.
 - a. Slurry residue should be vacuumed and disposed in a temporary pit (as described in On-Site
 - b. Temporary Concrete Washout Facility, Concrete Transit Truck Washout Procedures, below) and allowed to dry. Dispose of dry slurry residue in accordance with WM-5, Solid Waste Management.

Onsite Temporary Concrete Washout Facility, Transit Truck Washout Procedures

1. Temporary concrete washout facilities should be located a minimum of 50 ft from storm drain inlets, open drainage facilities, and watercourses. Each facility should be located away from construction traffic or access areas to prevent disturbance or tracking.
2. A sign should be installed adjacent to each washout facility to inform concrete equipment operators to utilize the proper facilities.
3. Temporary concrete washout facilities should be constructed above grade or below grade at the option of the contractor. Temporary concrete washout facilities should be constructed and maintained in sufficient quantity and size to contain all liquid and concrete waste generated by washout operations.
4. Temporary washout facilities should have a temporary pit or bermed areas of sufficient volume to completely contain all liquid and waste concrete materials generated during washout procedures.
5. Washout of concrete trucks should be performed in designated areas only.
6. Only concrete from mixer truck chutes should be washed into concrete wash out.
7. Concrete washout from concrete pumper bins can be washed into concrete pumper trucks and discharged into designated washout area or properly disposed of offsite.
8. Once concrete wastes are washed into the designated area and allowed to harden, the concrete should be broken up, removed, and disposed of per WM-5, Solid Waste Management. Dispose of hardened concrete on a regular basis.
9. Temporary Concrete Washout Facility (Type Above Grade)
10. Temporary concrete washout facility (type above grade) should be constructed as shown on the details at the end of this BMP, with a recommended minimum length a minimum width of 10 ft, but with sufficient quantity and volume to contain all liquid and concrete waste generated by washout operations.
 - a. Straw bales, wood stakes, and sandbag materials should conform to the provisions in SE-9, Straw Bale Barrier.
 - b. Plastic lining material should be a minimum of 10 mil in polyethylene sheeting and should be free of holes, tears, or other defects that compromise the impermeability of the material.
11. Temporary Concrete Washout Facility (Type Below Grade)
 - a. Temporary concrete washout facilities (type below grade) should be constructed as shown on the details at the end of this BMP, with a recommended minimum length and minimum width of 10 ft. The quantity and volume should be sufficient to contain all liquid and concrete waste generated by washout operations.
 - b. Lath and flagging should be commercial type.
 - c. Plastic lining material should be a minimum of 10 mil polyethylene sheeting and should be free of holes, tears, or other defects that compromise the impermeability of the material.

Removal of Temporary Concrete Washout Facilities

1. When temporary concrete washout facilities are no longer required for the work, the hardened concrete should be removed and disposed of. Materials used to construct temporary concrete washout facilities should be removed from the site of the work and disposed of.
2. Holes, depressions or other ground disturbance caused by the removal of the temporary concrete washout facilities should be backfilled and repaired.

Costs

All of the above are low cost measures.

Inspection and Maintenance

1. Inspect and verify that activity-based BMPs are in place prior to the commencement of associated activities. While activities associated with the BMP are under way, inspect weekly during the rainy season and of two-week intervals in the non-rainy season to verify continued BMP implementation.
2. Temporary concrete washout facilities should be maintained to provide adequate holding capacity with a minimum freeboard of 4 in. for above grade facilities and 12 in. for below grade facilities. Maintaining temporary concrete washout facilities should include removing and disposing of hardened concrete and returning the facilities to a functional condition.
3. Hardened concrete materials should be removed and disposed of.
4. Washout facilities must be cleaned, or new facilities must be constructed and ready for use once the washout is 75% full.

References

Blueprint for a Clean Bay: Best Management Practices to Prevent Stormwater Pollution from Construction Related Activities; Santa Clara Valley Nonpoint Source Pollution Control Program, 1995.

Stormwater Quality Handbooks - Construction Site Best Management Practices (BMPs) Manual, State of California Department of Transportation (Caltrans), November 2000.

Stormwater Management for Construction Activities; Developing Pollution Prevention Plans and Best Management Practice, EPA 832-R-92005; USEPA, April 1992.

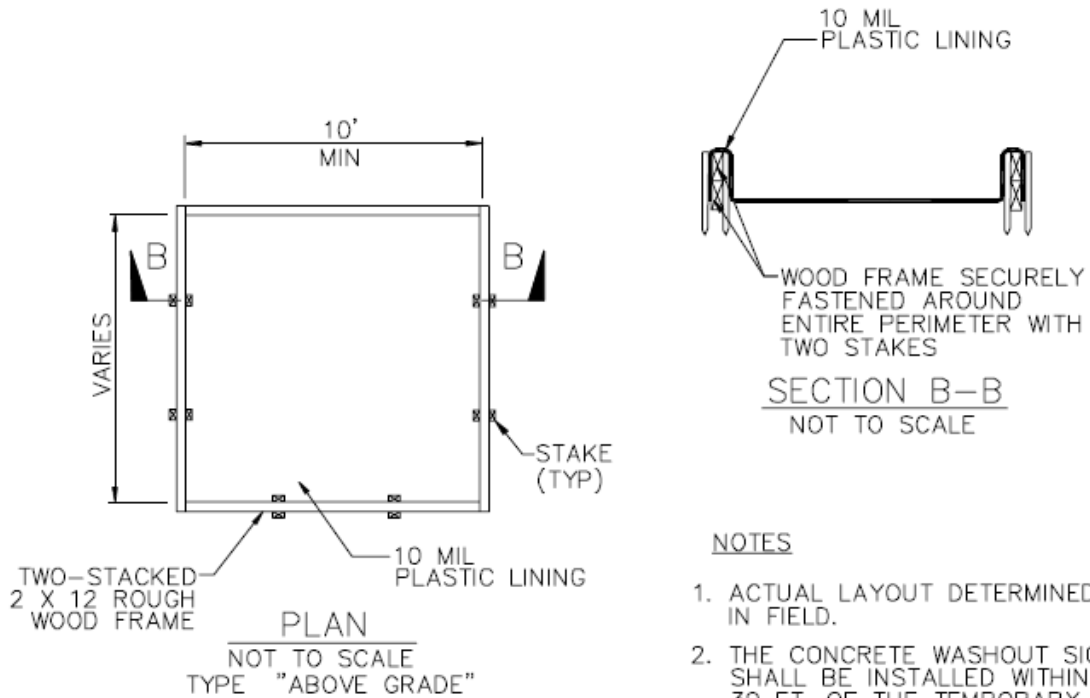
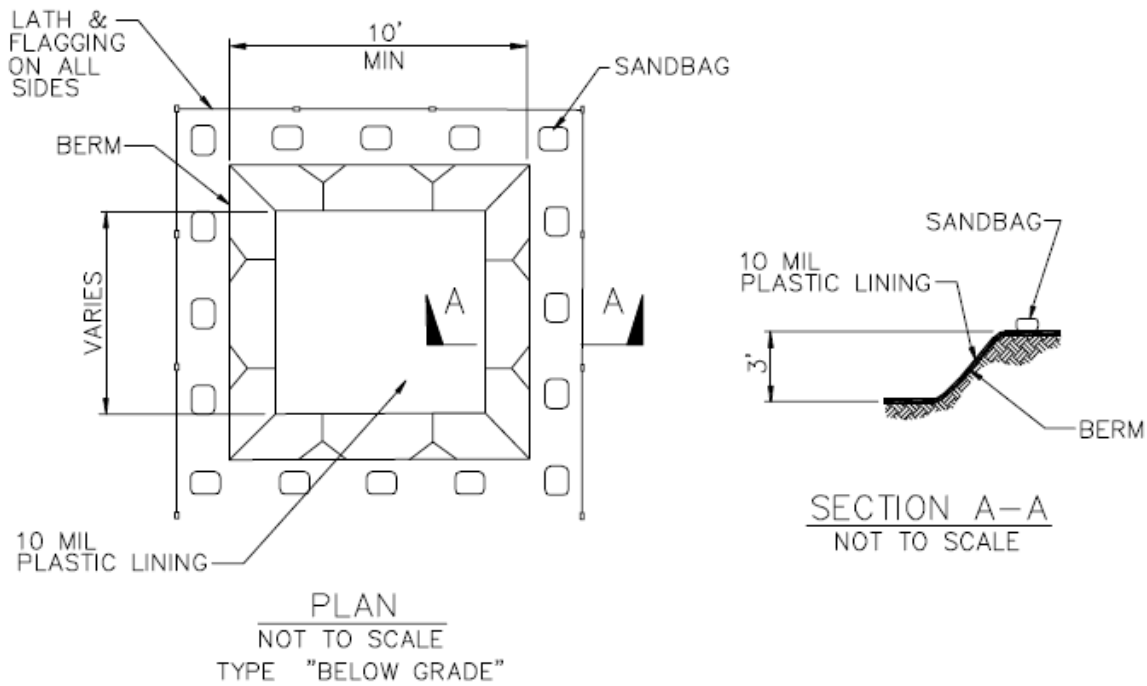

NOTES

1. ACTUAL LAYOUT DETERMINED IN FIELD.
2. THE CONCRETE WASHOUT SIGN SHALL BE INSTALLED WITHIN 30 FT. OF THE TEMPORARY CONCRETE WASHOUT FACILITY.

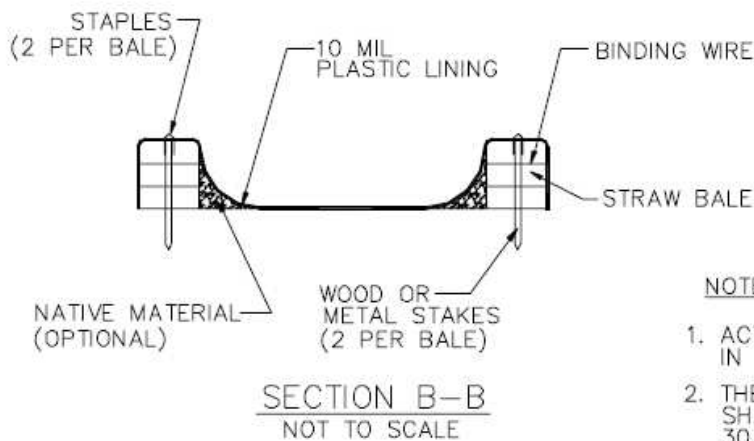
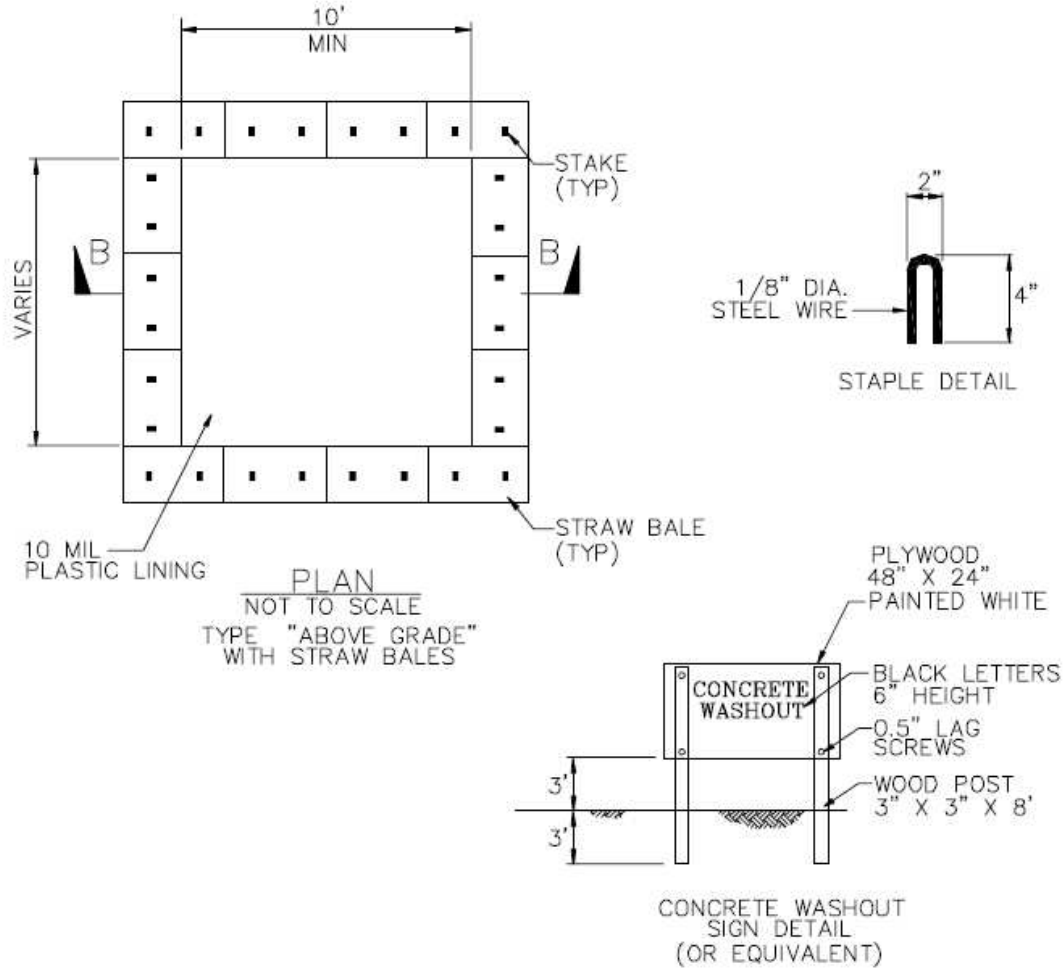

NOTES

1. ACTUAL LAYOUT DETERMINED IN FIELD.
2. THE CONCRETE WASHOUT SIGN SHALL BE INSTALLED WITHIN 30 FT. OF THE TEMPORARY CONCRETE WASHOUT FACILITY.

END OF SECTION