

TYPICAL SECTION

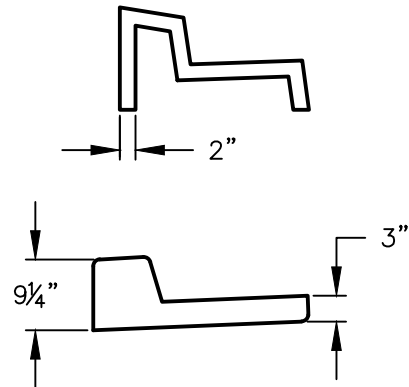

CONTRACTION JOINTS

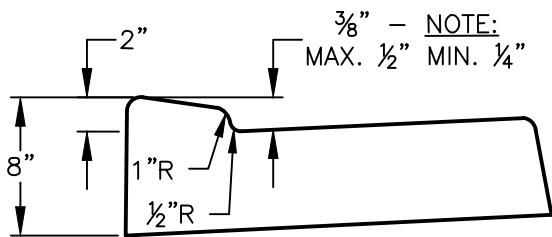

DRIVEWAY SECTION

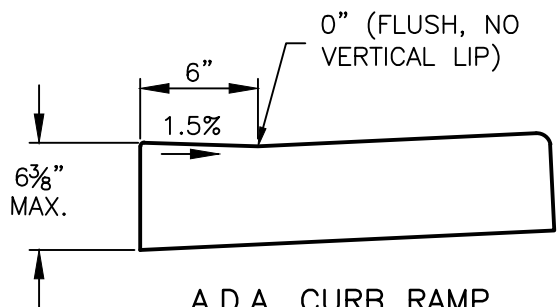

A.D.A. CURB RAMP

NOTES:

1. CONTRACTION JOINTS OF ONE OF THE TYPES SHOWN ABOVE TO BE PLACED 10' C/C. JOINTS MUST COMPLETELY SEVER THE STRUCTURE TO THE POINTS SHOWN. JOINTS MAY BE MADE BY INSERTING MIN. 3/16" BITUMINOUS FILLER DUMMY JOINTS. JOINTS SHALL BE CLEANED AND EDGED.
2. ALL RADII LESS THAN 100' SHALL USE FLEXIBLE WOOD OR METAL FORMS TO ELIMINATE ANGULAR POINTS AT 10' SECTION POINTS.
3. 2"Ø PVC SCHD 40 WEEP HOLES TO BE PLACED ON EACH SIDE OF DRIVEWAY SECTION AND AT MAX. OF 60' C/C IN CUT SECTIONS WHERE SIDEWALK DRAIN NOT REQUIRED BY CITY ENGINEER.
4. 1/2" EXPANSION JOINTS TO BE PLACED AT DRIVEWAY SECTIONS, CURB RETURNS, CURB RAMPS, & COLD JOINTS OR A MAX. OF 80' C/C. EXPANSION JOINTS SHALL PROTRUDE 1" BELOW THE BOTTOM OF GUTTER.
5. CONCRETE SHALL BE COMMERCIAL CONCRETE CLASS 3000 PER WSDOT SPEC. 6-02.3(2)B.
6. FINISHED WORK SHALL NOT VARY MORE THAN 1/8-INCH IN GRADE AND 1/4-INCH IN ALIGNMENT WHEN CHECKED WITH A 10-FOOT STRAIGHT EDGE.
7. EXPOSED SURFACES SHALL BE BRUSHED WITH A FIBER HAIR BRUSH.
8. WHITE PIGMENTED OR TRANSPARENT CURING COMPOUND SHALL BE APPLIED AS OUTLINED IN THE STANDARD SPECIFICATIONS.
9. FURTHER REQUIREMENTS SHALL BE AS SPECIFIED IN THE STANDARD SPECIFICATIONS.

APPROVED

City Engineer

Date

CITY OF BELLINGHAM

CURB AND GUTTER

DRAWING

CG-200