

NOTE:

SAMPLE TAP TO BE INSTALLED WHERE HYDRANT SPOOL IS GREATER THAN ONE STICK OF PIPE OR CONTAINS A BELL JOINT.

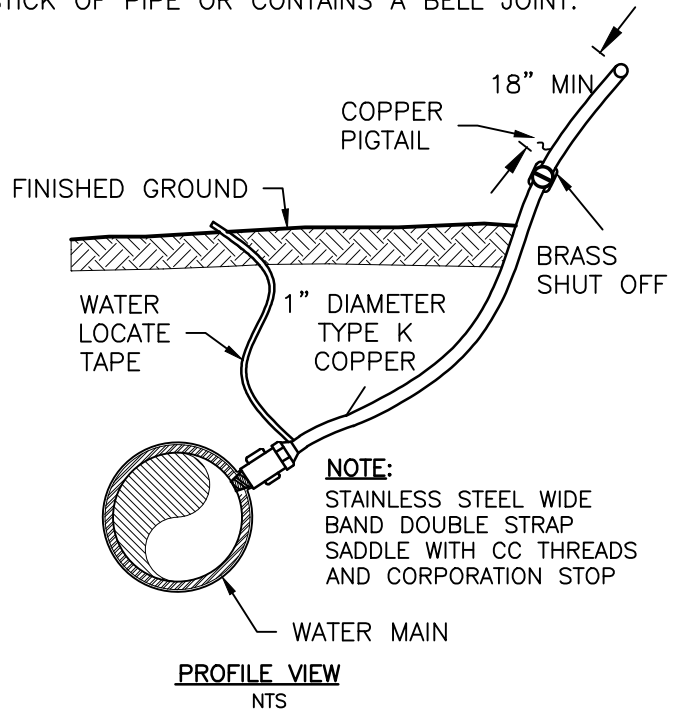
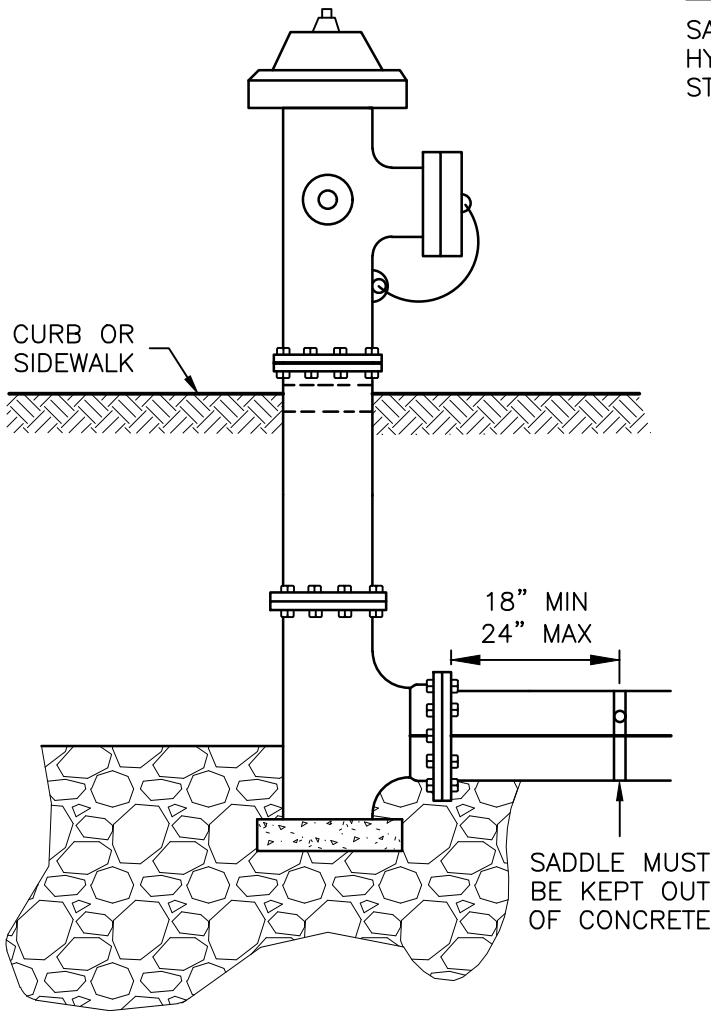

AFTER SAMPLING PROCEDURE, DISCONTINUE SERVICE AS FOLLOWS:

1. SHUT OFF CORPORATION STOP
2. REMOVE COPPER PIPE AND SHUTOFF
3. ATTACH LOCATE TAPE TO CORPORATION STOP
4. CAP CORPORATION STOP
5. BACKFILL WITH LOCATE TAPE TRAILING UP

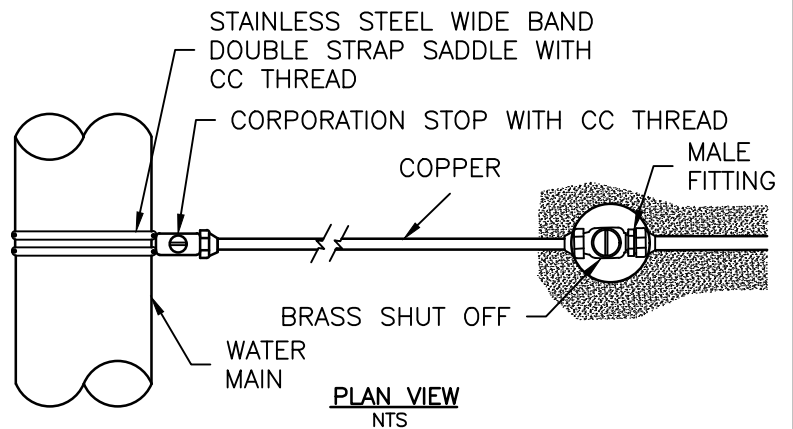

APPROVED

City Engineer

Date

CITY OF BELLINGHAM

SAMPLE TAP ON FIRE HYDRANT

DRAWING

WA-803