

DETAIL C
FOOTING DETAIL

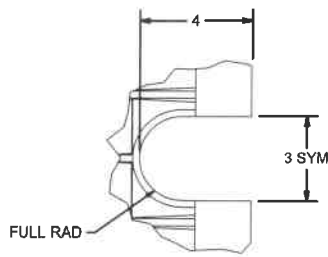

DETAIL D
MOUSEHOLE DETAIL, THRU BOTH ENDS

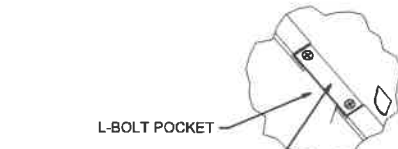

L-BOLT POCKET
L-BOLT RETAINING PLATE
(OPTIONAL, SOLD SEPARATELY)
DETAIL E
OPTIONAL L-BOLT RETAINING PLATE



SST SPEED NUT,
AVAIL AS 1/2-13
OR 3/8-16.
(OPTIONAL, SOLD
SEPARATELY)
DETAIL F
OPTIONAL SST SPEED NUT

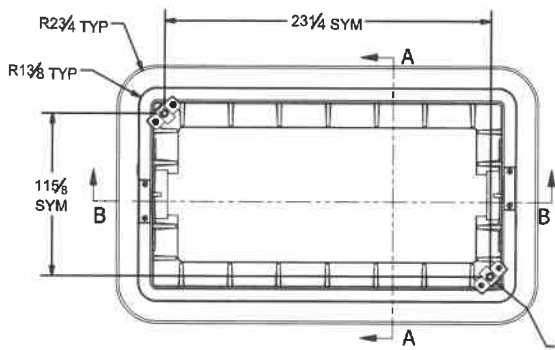

OPTIONAL SPEED NUT
(SEE DETAIL F)

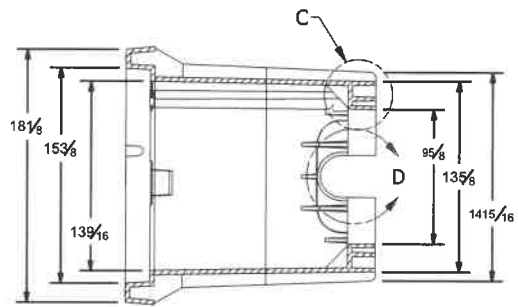

SECTION A-A

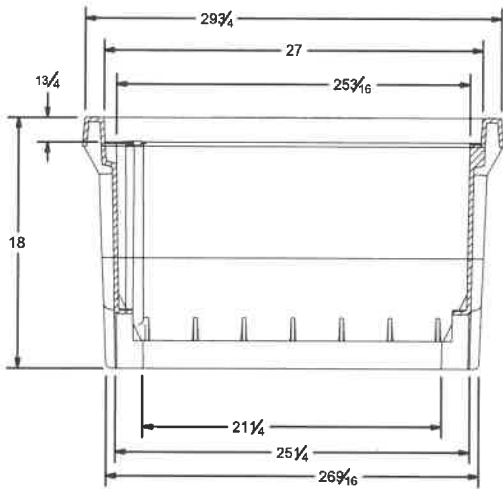

SECTION B-B

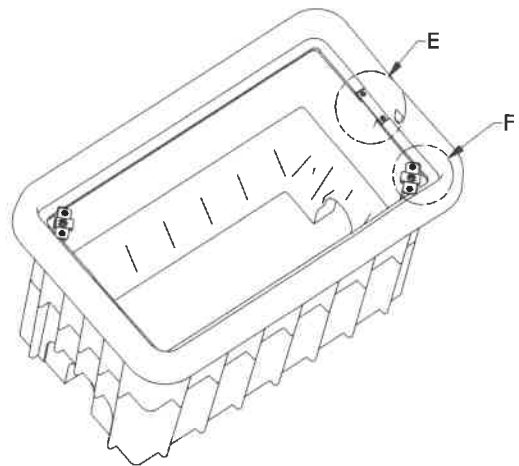

EST. WEIGHT: 21.75 LBS
MATERIAL: HIGH DENSITY POLYETHYLENE, BLACK
ALL DIMENSIONS IN INCHES

APPROVED

City Engineer

14 Nov 2019
Date

CITY OF BELLINGHAM
STANDARD RESIDENTIAL
METER BOX

DRAWING
WA-850
1 of 2

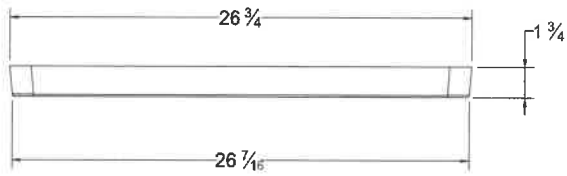
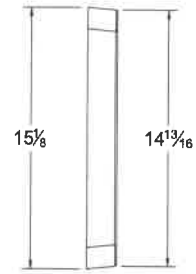
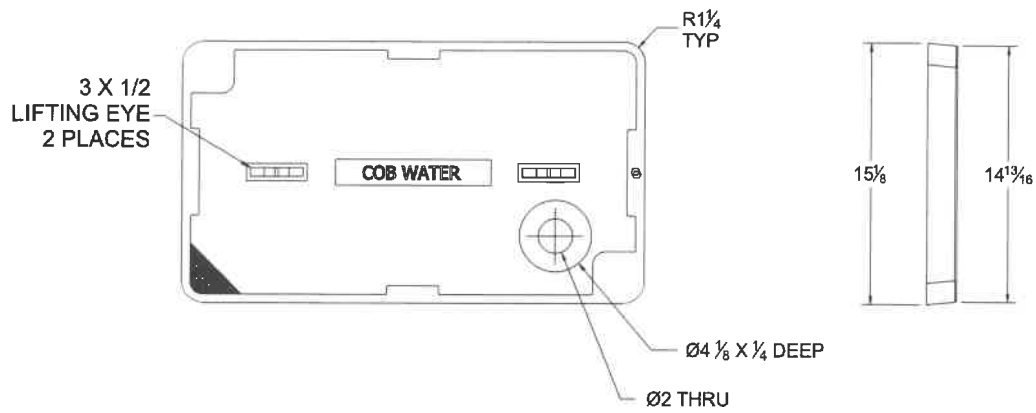

NON-SKID TREAD PATTERN
PARTIALLY OMITTED
FOR CLARITY

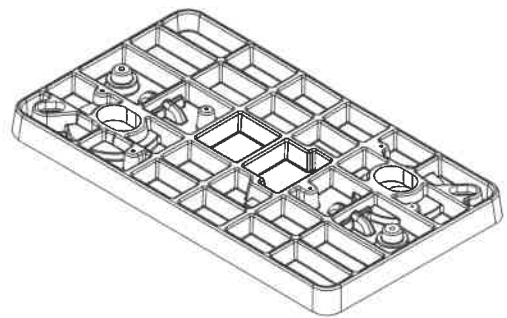
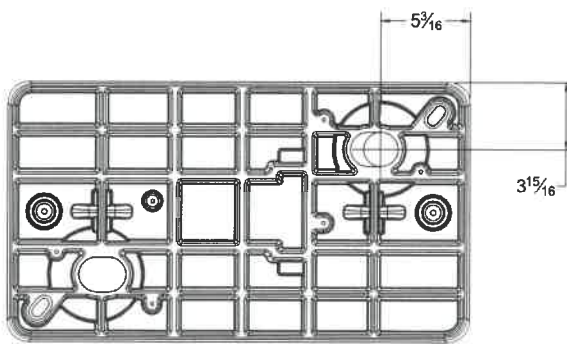
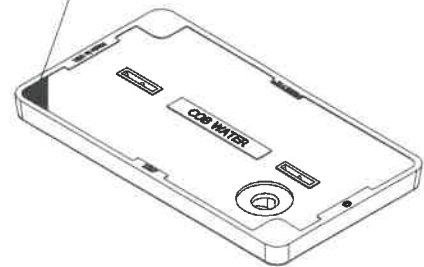

MATERIAL: POLYMER COMPOSITE
ALL DIMENSIONS IN INCHES

APPROVED

City Engineer

14 Nov 2019
Date

CITY OF BELLINGHAM
STANDARD RESIDENTIAL
METER BOX

DRAWING
WA-850
2 of 2