

Preliminary Stormwater Management Report

THE WOODS AT VIEWCREST



Photo Courtesy of the WSDOE Coastal Atlas

December 4, 2023

Prepared by:

Pacific Surveying and Engineering Services, Inc.
909 Squaticum Way, Suite 11
Bellingham, Washington 98225
(360) 671-7387
www.psesurvey.com

Prepared for:

Ann C. Jones Family
807 Chuckanut Shore Road
Bellingham, Washington 98229

1 TABLE OF CONTENTS

1	TABLE OF CONTENTS	1
2	CERTIFICATION	3
3	INTRODUCTION	4
3.1	PURPOSE AND OBJECTIVES	4
3.2	PROJECT BACKGROUND	4
4	EXISTING CONDITIONS.....	5
4.1	LAND USE & ZONING	5
4.2	VEGETATION.....	5
4.3	EXISTING SOIL CONDITIONS.....	5
4.4	TOPOGRAPHY & DRAINAGE	5
5	STORMWATER SYSTEM EVALUATION.....	6
5.1	SITE IMPROVEMENTS	6
5.2	FLOW CONTROL.....	6
5.3	WATER QUALITY	6
5.4	OUTFALL TO SALTWATER.....	6
6	MINIMUM STORMWATER MANAGEMENT REQUIREMENTS	8
6.1	REQUIREMENT NO. 1 – PREPARE STORMWATER SITE PLANS	8
6.1.1	COLLECT AND ANALYZE EXISTING CONDITIONS INFORMATION	8
6.1.2	PREPARE PRELIMINARY DEVELOPMENT LAYOUT	8
6.1.3	PERFORM OFF-SITE ANALYSIS	8
6.1.4	DETERMINE APPLICABLE MINIMUM REQUIREMENTS.....	8
6.1.5	PREPARE A PERMANENT STORMWATER CONTROL PLAN	8
6.1.5 (1)	EXISTING SITE HYDROLOGY	8
6.1.5 (2)	DEVELOPED SITE HYDROLOGY	8
6.1.5 (3)	PERFORMANCE STANDARDS AND GOALS	8
6.1.5 (4)	FLOW CONTROL SYSTEM	9
6.1.5 (5)	WATER QUALITY SYSTEM.....	9
6.1.5 (6)	CONVEYANCE SYSTEM ANALYSIS AND DESIGN	9
6.1.6	PREPARE A CONSTRUCTION STORM WATER POLLUTION PREVENTION PLAN.....	9
6.1.7	COMPLETE THE STORM WATER SITE PLAN.....	9
6.1.8	CHECK COMPLIANCE WITH ALL APPLICABLE MINIMUM REQUIREMENTS.....	9
6.2	REQUIREMENT NO. 2 – CONSTRUCTION STORMWATER POLLUTION PREVENTION (SWPPP)	10
6.2.1	ELEMENT #1 - MARK CLEARING LIMITS.....	10
6.2.2	ELEMENT #2 - ESTABLISH CONSTRUCTION ACCESS	10
6.2.3	ELEMENT #3 - CONTROL FLOW RATES.....	10
6.2.4	ELEMENT #4 - INSTALL SEDIMENT CONTROLS	10
6.2.5	ELEMENT #5 - STABILIZE SOILS.....	11
6.2.6	ELEMENT #6 - PROTECT SLOPES	11
6.2.7	ELEMENT #7 - PROTECT DRAIN INLETS.....	12
6.2.8	ELEMENT #8 - STABILIZE CHANNELS AND OUTLETS	12
6.2.9	ELEMENT #9 - CONTROL POLLUTANTS.....	12
6.2.10	ELEMENT #10 - CONTROL DE-WATERING	13

6.2.11	ELEMENT #11 - MAINTAIN BMPS.....	13
6.2.12	ELEMENT #12 - MANAGE THE PROJECT	14
6.2.13	ELEMENT #13 – PROTECT LOW IMPACT DEVELOPMENT BMP'S	14
6.3	REQUIREMENT NO. 3 – SOURCE CONTROL OF POLLUTION	14
6.4	REQUIREMENT NO. 4 – PRESERVATION OF NATURAL DRAINAGE SYSTEMS AND OUTFALLS	16
6.5	REQUIREMENT NO. 5 – ON-SITE STORM WATER MANAGEMENT.....	16
6.6	REQUIREMENT NO. 6 – RUNOFF TREATMENT	17
6.7	REQUIREMENT NO. 7 – FLOW CONTROL	17
6.8	REQUIREMENT NO. 8 – WETLANDS PROTECTION	17
6.9	REQUIREMENT NO. 9 – OPERATION AND MAINTENANCE	17
7	PRINCIPAL FINDINGS AND RECOMMENDATIONS	18
8	APPENDIX	
8.1	VICINITY MAP	19
8.2	NRCS SOILS REPORT.....	20
8.3	GEOLOGIC FEASIBILITY INVESTIGATION	21
8.4	BASIN MAP.....	22
8.5	DRAWINGS	23
8.6	CRITICAL AREAS SUMMARY	24
8.7	GULD FOR MODULAR WETLAND SYSTEM	25

2 CERTIFICATION

ENGINEER'S DECLARATION

I, Jeff Vander Yacht, a Professional Engineer registered in the State of Washington as a Civil Engineer, do hereby declare that the Stormwater Design Report titled "Preliminary Stormwater Management Report – The Woods at Viewcrest", dated December 4, 2023, was prepared by me, or under my personal supervision, and that said Report was prepared in accordance with generally accepted engineering practices.

Respectfully,



12-04-2023

Jeff Vander Yacht, P.E.
Registration No. 37432
Pacific Surveying & Engineering

3 INTRODUCTION

3.1 PURPOSE AND OBJECTIVES

This preliminary storm water management report has been prepared on behalf of the Jones Family who are proposing to construct a 38-home residential development and associated roads, driveways, trails and utilities. This report is provided as a general overview of the stormwater best management practices that will be implemented. This report has been prepared to support the Preliminary Plat application review process.

The purpose of this report is to evaluate the impacts of the development regarding stormwater management, to detail the methods and assumptions used for this evaluation and present mitigation design recommendations.

Proposed measures include implementation of best management practices (BMP's) designed to assure post development conditions meet or exceed minimum requirements outlined by the City of Bellingham's Municipal Code (BMC) and applicable sections of the Washington State Department of Ecology "Storm Water Management Manual for Western Washington", 2019 publication (hereinafter referred to as the DOE Manual). This report functions as a combined 'Storm Water Management Plan' and 'Storm Water Pollution Prevention Plan' (SWPPP). A SWPPP has been developed within this report to detail temporary erosion control and stormwater pollution prevention requirements during construction.

3.2 PROJECT BACKGROUND

General information for this project is as follows:

PROJECT NAME:	The Woods at Viewcrest
LOCATION:	807 Chuckanut Shore Road Bellingham, WA 98229-8925
DESCRIPTION:	Construction of two public roads, single family residential lots and associated access and utility improvements.
OWNER:	Ann C. Jones Family LP 807 Chuckanut Shore Rd, Bellingham, WA. 98229 Ph: (360)301-320-4145
ENGINEER & CONTACT:	Jeff Vander Yacht, P.E. Pacific Surveying & Engineering 909 Squalicum Way, Suite 111, Bellingham, WA. 98225 Ph: (360) 671-7387, Fax: (360) 671-4685

4 EXISTING CONDITIONS

4.1 LAND USE & ZONING

The project property is approximately 21 acres in the Edgemoor neighborhood in subarea 7 and is zoned as single-family residential. Residential housing is located to the north, east, and west of the project area, and the site is bounded by Viewcrest Rd to the north, S. Clarkwood Dr, to the west, and Sea Pines Rd to the east. The southern boundary of the property abuts Chuckanut Bay. A Vicinity Map showing the project location is included in Appendix 8.1.

4.2 VEGETATION

The site is currently undeveloped, and no structures exist within the project site. The site is primarily forested with wide variety of second growth timber, shrubs and herbaceous plants.

4.3 EXISTING SOIL CONDITIONS

In the vicinity of the proposed site improvements soils consist of mainly of Everett-Urban loam (unit 52) with a hydrologic soil group rating B per the NRCS Web Soil Survey. Small areas of the project site are composed of Nati loam (Unit 110) with a hydrologic soil group rating C per NRCS Web Soil Survey. The complete NRCS soil survey can be found in Appendix 8.2

A Geologic Feasibility Investigation was prepared for this parcel of land by Element Solutions. That report is attached as Appendix 8.3.

4.4 TOPOGRAPHY & DRAINAGE

The topography is steep and generally slopes downward to the south towards Chuckanut Bay, with some slopes exceeding 30%. Stormwater from the site generally follows this flow path, and sheet flows directly to Chuckanut Bay. Two small portions of the site drain either to the north towards Viewcrest Dr or to the west towards S. Clarkwood drive and then flow into City of Bellingham storm sewers which discharge to Chuckanut Bay. The discharge locations for these basins are separated by a minimum of 0.38 miles, therefore the project site is considered to be three separate Threshold Discharge Areas (TDA's). The area of the site that sheet flows directly to Chuckanut Bay is identified as TDA 2, the area that drains to the Viewcrest Rd storm sewer is identified as TDA 1, and the area draining to the west into S.Clarkwood Dr. is identified as TDA 3. See the Basin Map in Appendix 8.4.

We have reviewed the City of Bellingham's 2020 Surface and Stormwater Comprehensive Plan. No known conveyance deficiencies exist downstream of the Jones Edgemoor project between the outfall for TDA 1 and the discharge point of the city storm sewer into Chuckanut Bay.

5 STORMWATER SYSTEM EVALUATION

5.1 SITE IMPROVEMENTS

This project proposes to construct 38 single family homes, two public roads, sidewalks, private roads, driveways, and associated public trails and utilities. The project will result in approximately 51,951 SF of asphalt roadways and 11,320 SF of concrete sidewalk. In addition, this project proposes to meet water quality treatment requirements through the use of two modular wetland treatment systems.

5.2 FLOW CONTROL

Stormwater runoff from TDA 2 directly discharges into Chuckanut Bay, which is considered a flow control exempt saltwater body. Therefore, this TDA is exempt from flow control requirements per BMC 15.42. TDA 3 will not contain any proposed hard surfaces, therefore this TDA is exempt from flow control requirements. Site improvements associated with TDA 1 will result in more than 10,000 SF of hard surfaces triggering flow-control requirements. These requirements will be met through use of a subsurface detention vault including a flowrate restrictor orifice structure. Since the Viewcrest Road stormwater system conveys stormwater directly to Chuckanut Bay, it is possible that the stormwater detention vault could be eliminated if the downstream storm sewer systems are proven to be adequately sized to convey the flows. This analysis may be conducted in the future as the development plans become more detailed.

5.3 WATER QUALITY

This project proposes more than 5,000 SF of pollution generating new plus replaced impervious surfacing (including private on-site work permitted separately), therefore is subject to water quality requirements outlined in the BMC 15.42.

This project is required to meet basic water quality treatment standards per BMC 15.42. However, this project has elected to increase the level of stormwater treatment and meet the enhanced treatment level standard.

The project proposes enhanced treatment for the new and replaced pollution generating surfaces in TDA #1 and TDA #2 using two modular wetland devices. Each modular wetland device will be sized to meet the water quality treatment requirements for the area.

5.4 OUTFALL TO SALTWATER

This project proposes to outfall surface water runoff directly into Chuckanut Bay through a piped stormwater conveyance system. Surface water runoff from developed surfaces within TDA #2 will be collected in an underground pipe conveyance system and will discharge to Chuckanut Bay through an above ground pipe and energy dissipation device located immediately above the high tide line.

Site visits have been conducted to identify feasible locations where the above ground pipe and energy dissipator could be constructed while addressing aesthetic concerns about infrastructure visible from the shoreline, saltwater, and neighboring properties. An unmanned aerial drone was used to photograph the proposed location of the stormwater outfall pipe. The aerial photographs have been rendered to clearly depict how the outfall will appear after it is constructed. The rendered photographs can be viewed in the Plans in Appendix 8.05.

It is anticipated that all stormwater piping within proposed right of ways will be dedicated to the City and constructed to City standards to allow for future maintenance activities by the City. The

above ground storm pipe and energy dissipation outfall are also considered to be City owned and maintained infrastructure. As a result, the above ground pipe will also be designed and constructed to City standards.

Surface water runoff from TDA #1 will outfall to the existing Viewcrest Avenue enclosed stormwater conveyance system. This existing conveyance system also outfalls directly to Chuckanut Bay.

6 MINIMUM STORMWATER MANAGEMENT REQUIREMENTS

This project proposes more than 5,000 SF of pollution generating new plus replaced impervious surfacing.

Per BMC 15.42, this project is required to meet the Nine Minimum Stormwater Management Requirements. The nine minimum requirements have each been addressed as follows:

6.1 REQUIREMENT NO. 1 – PREPARE STORMWATER SITE PLANS

We have completed the requirements of a stormwater site plan per the WSDOE Manual. The required steps have been performed as follows:

6.1.1 COLLECT AND ANALYZE EXISTING CONDITIONS INFORMATION

Site visits were performed to determine the existing drainage conditions. Downstream conditions were investigated utilizing field surveyed topographic maps as well as site visit observations. See Section 4.4 above for a detailed description of existing site conditions.

6.1.2 PREPARE PRELIMINARY DEVELOPMENT LAYOUT

A preliminary site development plan has been prepared which shows the proposed access and drainage systems.

6.1.3 PERFORM OFF-SITE ANALYSIS

A qualitative off-site analysis has been completed in accordance with the WSDOE Manual. See section 4 above. Based on field observations and visual inspection of the downstream conveyance system, it is our determination that the proposed project will not adversely impact the existing stormwater systems.

6.1.4 DETERMINE APPLICABLE MINIMUM REQUIREMENTS

This project shall meet the nine minimum requirements for storm water management as outlined in BMC 15.42, which references the WSDOE Stormwater Management Manual for Western Washington, 2019 edition.

6.1.5 PREPARE A PERMANENT STORMWATER CONTROL PLAN

A permanent storm water control plan has been developed and presented herein, in accordance with the guidelines outlined in the Step 5 of Section 3.2, Volume III of the WSDOE Manual.

6.1.5 (1) EXISTING SITE HYDROLOGY

Existing conditions are explained in detail in Section 4. Geotechnical Report and Drainage Basin Exhibits can be found in Appendixes 8.2 and 8.4 respectively.

6.1.5 (2) DEVELOPED SITE HYDROLOGY

Proposed improvements to the site are discussed in Section 5 and detailed in Appendix 8.4 of this report. Drainage Basin Exhibits and Geotechnical Report can be found in Appendixes 8.2 and 8.3 respectively.

6.1.5 (3) PERFORMANCE STANDARDS AND GOALS

The project is a New Development Project that proposes more than 10,000 SF of new plus replaced impervious surface area and over 5,000 SF of new pollution generating impervious surface area. Based on the proposed improvements areas Minimum Requirements 1-9 apply to the project.

6.1.5 (4) FLOW CONTROL SYSTEM

TDA 2 – Chuckanut Bay is not subject to flow control requirements as it discharges directly to a flow control exempt water body. TDA 3 – S Clarkwood Dr will not contain any new plus replaced hard surfaces and will not be subject to flow control requirements. TDA 1 – Viewcrest Rd proposes more than 10,000 SF of new plus replaced impervious surfacing and will require flow control, unless it is determined that all existing storm sewers downstream of TDA 1 have the capacity to convey the surface water runoff directly to saltwater. As currently proposed, a detention vault and flow control system will be used to ensure post-developed runoff does not exceed allowable release rates.

6.1.5 (5) WATER QUALITY SYSTEM

The project is subject to water quality system requirements as this project results in more than 5,000 square feet of pollution generating new plus replaced impervious surface per the WSDOE Manual. In TDA 2 – Chuckanut Bay, a modular wetland is proposed to meet water quality requirements for all proposed pollution generating hard surfaces in the area. In TDA 1 – Viewcrest Road, a modular wetland device is proposed to meet water quality requirements for all proposed pollution generating hard surfaces in the area. Both facilities will be sized to treat a minimum of 91% of the runoff for this project. In TDA 3 – S Clarkwood Dr, no pollution generating surfaces are proposed and therefore water quality treatment will not be required.

6.1.5 (6) CONVEYANCE SYSTEM ANALYSIS AND DESIGN

Stormwater Conveyance systems within the project area have been sized to adequately convey stormwater runoff from the site.

6.1.6 PREPARE A CONSTRUCTION STORM WATER POLLUTION PREVENTION PLAN

Construction Storm Water Pollution Prevention Plan (SWPPP) and temporary erosion and sediment controls will be implemented, See section 6.2 below, during the construction of the project. Permanent storm water control shall be implemented in the completed project as outlined above in Section 6.1.5 of this report.

6.1.7 COMPLETE THE STORM WATER SITE PLAN

A Preliminary Storm Water Site Plan has been prepared according to the WSDOE Manual.

6.1.8 CHECK COMPLIANCE WITH ALL APPLICABLE MINIMUM REQUIREMENTS

The storm water management facilities proposed in this report comply with all of the applicable standards of the WSDOE Manual.

6.2 REQUIREMENT NO. 2 – CONSTRUCTION STORMWATER POLLUTION PREVENTION (SWPPP)

A Storm Water Pollution Prevention Plan (SWPPP) has been developed. The SWPPP consists of two parts: a narrative and a set of site plan drawings. The narrative portion consists of the thirteen SWPPP elements per WSDOE Manual described below in addition to other components of this storm water report including descriptions of existing site conditions, proposed project, critical areas, soils, etcetera. The site plan drawings depict implementation of BMP's and can be seen in Appendix 7.3, "Stormwater Site Plan". Additional descriptions of the BMPs are included in Appendix 7.4, *Construction Source Control BMPs*.

6.2.1 ELEMENT #1 - MARK CLEARING LIMITS

Prior to beginning land disturbing activities, including clearing and grading, all clearing limits, sensitive areas and their buffers, and trees that are to be preserved within the construction area should be clearly marked, both in the field and on the plans, to prevent damage and offsite impacts. Plastic, metal, or stake wire fence may be used to mark the clearing limits.

6.2.2 ELEMENT #2 - ESTABLISH CONSTRUCTION ACCESS

(a) Construction vehicle access and exit shall be limited to one route on Viewcrest drive where the public road is to be built.

(b) Access points shall be stabilized with quarry spalls or crushed rock to minimize the tracking of sediment onto public roads per WSDOE BMP C105: Stabilized Construction Entrance.

(c) Wheel wash or tire baths are not anticipated to be needed for this project.

(d) Public roads shall at a minimum be cleaned thoroughly at the end of each day. Sediment shall be removed from roads by shoveling or pickup sweeping and shall be transported to a controlled sediment disposal area. Street washing will be allowed only after sediment is removed in this manner.

(e) Street wash wastewater shall be controlled by pumping back on-site, or otherwise be prevented from discharging into systems tributary to state surface waters.

6.2.3 ELEMENT #3 - CONTROL FLOW RATES

(a) Properties and waterways downstream from development sites shall be protected from erosion due to increases in the volume, velocity, and peak flow rate of stormwater runoff from the project site.

6.2.4 ELEMENT #4 - INSTALL SEDIMENT CONTROLS

(a) The duff layer, native topsoil, and natural vegetation shall be retained in an undisturbed state to the maximum extent practicable until after the stormwater conveyance system has been installed.

(b) Prior to leaving a construction site, stormwater runoff from disturbed areas shall pass through a sediment pond or other appropriate sediment removal BMP that is shown in the temporary erosion and sedimentation control plan. Runoff from fully stabilized areas may be discharged without a sediment removal BMP, but must meet the flow control performance standard of element 3 above. Full stabilization means concrete or asphalt paving; quarry spalls used as ditch lining; or the use of rolled erosion products, a bonded fiber matrix product, or vegetative cover in a manner that will fully prevent soil erosion. Sediment ponds, vegetated buffer strips, sediment barriers or filters, dikes, and other BMPs intended to trap sediment on-site shall be constructed as

one of the first steps in grading. These BMPs shall be functional before other land disturbing activities take place.

(c) Earthen structures such as dams, dikes, and diversions shall be seeded and mulched according to the timing indicated in element 5 below.

The minimum required sediment control WSDOE BMPs are C233: Silt Fence.

6.2.5 ELEMENT #5 - STABILIZE SOILS

(a) All exposed and unworked soils shall be stabilized by application of effective BMPs that protect the soil from the erosive forces of raindrop impact and flowing water, and wind erosion.

(b) From October 1 through April 30 of each year, no soils shall remain exposed and unworked for more than 2 days. From May 1 to September 30 of each year, no soils shall remain exposed and unworked for more than 7 days. This condition applies to all soils on site, whether at final grade or not.

(c) Applicable practices include, but are not limited to, temporary and permanent seeding, sodding, mulching, plastic covering, soil application of polyacrylamide (pam), early application of gravel base on areas to be paved, and dust control.

(d) Soil stabilization measures selected should be appropriate for the time of year, site conditions, estimated duration of use, and potential water quality impacts that stabilization agents may have on downstream waters or ground water.

(e) Soil stockpiles must be stabilized and protected with sediment trapping measures.

(f) Work on linear construction sites and activities, including right-of-way and easement clearing, roadway development, pipelines, and trenching for utilities, shall not exceed the capability of the individual contractor for his portion of the project to install the bedding materials, roadbeds, structures, pipelines, and/or utilities, and to re-stabilize the disturbed soils, meeting the timing conditions listed above.

(g) In addition, at the discretion of the technical administrator, those sites unable to maintain the quality of their stormwater discharge may be required to provide soil stabilization to all exposed soil areas regardless of the working status of the area. Upon written notification, the property owner shall provide full stabilization of all exposed soil areas within 24 hours.

The minimum required soil stabilizing WSDOE BMPs are C120: Temporary and Permanent Seeding, C121 Mulching, C140 Dust Control.

6.2.6 ELEMENT #6 - PROTECT SLOPES

(A) Cut and fill slopes shall be designed and constructed in a manner that will minimize erosion.

(B) Consider soil type and its potential for erosion.

(C) Reduce slope runoff velocities by reducing the continuous length of slope with terracing and diversions, reduce slope steepness, and roughen slope surface.

(D) Divert upslope drainage and run-on waters from off-site with interceptors at top of slope. Off-site stormwater should be handled separately from stormwater generated on the site. Diversion of off-site stormwater around the site may be a viable option. Diverted flows shall be redirected to the natural drainage location at or before the property boundary.

- (E) Contain down slope collected flows in pipes, slope drains, or protected channels.
- (F) Provide drainage to remove ground water intersecting the slope surface of exposed soil areas.
- (G) Excavated material shall be placed on the uphill side of trenches, consistent with safety and space considerations.
- (H) Check dams shall be placed at regular intervals within trenches that are cut down a slope.
- (I) Stabilize soils on slopes, as specified in element #5.

In addition to BMP's listed in element #5 above, if required the minimum slope protection BMP's are: C120 Temporary and Permanent Seeding

6.2.7 ELEMENT #7 - PROTECT DRAIN INLETS

(a) All storm drain inlets made operable during construction shall be protected so that stormwater runoff shall not enter the conveyance system without first being filtered or treated to remove sediment. The required BMP is: C220 Storm Drain Inlet Protection

(b) All approach roads shall be kept clean, and all sediment and street wash water shall not be allowed to enter storm drains without prior and adequate treatment unless treatment is provided before the storm drain discharges to waters of the state.

6.2.8 ELEMENT #8 - STABILIZE CHANNELS AND OUTLETS

(a) No permanent open channels are proposed for construction. If temporary open channels are constructed, they shall be designed and constructed then stabilized to prevent erosion from the expected velocity of flow from a 2 year, 24-hour frequency storm for the developed condition.

(b) Stabilization, including armoring material, adequate to prevent erosion of outlets, adjacent stream banks, slopes and downstream reaches shall be provided at the outlets of all conveyance systems.

6.2.9 ELEMENT #9 - CONTROL POLLUTANTS

(a) All pollutants, including waste materials and demolition debris, that occur on-site during construction shall be handled and disposed of in a manner that does not cause contamination of stormwater.

(b) Cover, containment, and protection from vandalism shall be provided for all chemicals, liquid products, petroleum products, and non-inert wastes present on the site (see chapter 173-304 WAC, as currently enacted or hereafter modified, for the definition of inert waste, which is incorporated herein by this reference).

(c) Maintenance and repair of heavy equipment and vehicles involving oil changes, hydraulic system drain down, solvent and de-greasing cleaning operations, fuel tank drain down and removal, and other activities which may result in discharge or spillage of pollutants to the ground or into stormwater runoff must be conducted using spill prevention measures, such as drip pans. Contaminated surfaces shall be cleaned immediately following any discharge or spill incident. Emergency repairs may be performed on-site using temporary plastic placed beneath and, if raining, over the vehicle.

(d) There is no anticipated need for wheel wash, or tire bath wastewater, for this project. If the need were to arise the wheel wash, or tire bath wastewater shall be discharged to a separate on-site treatment system or to the sanitary sewer.

(e) Application of agricultural chemicals, including fertilizers and pesticides, shall be conducted in a manner and at application rates that will not result in loss of chemicals to stormwater runoff. Manufacturers' recommendations shall be followed for application rates and procedures. There is no anticipated use for agricultural chemicals, including fertilizers and pesticides for this project.

(f) Management of pH-modifying sources shall prevent contamination of runoff and stormwater collected on the site. These sources include, but are not limited to, bulk cement, cement kiln dust, fly ash, new concrete washing and curing waters, waste streams generated from concrete grinding and sawing, exposed aggregate processes, and concrete pumping and mixer washout waters. The minimum required BMP is: C151 Concrete Handling.

6.2.10 ELEMENT #10 - CONTROL DE-WATERING

(a) All foundation, vault, and trench de-watering water, which has similar characteristics to stormwater runoff at the site, shall be discharged into a controlled conveyance system, prior to discharge to a sediment trap or sediment pond. Channels must be stabilized, as specified in element #8.

(b) Clean, non-turbid de-watering water, such as well-point ground water, can be discharged to systems tributary to state surface waters, as specified in element #8, provided the de-watering flow does not cause erosion or flooding of the receiving waters. These clean waters should not be routed through sediment ponds with stormwater.

(c) Highly turbid or otherwise contaminated dewatering water, such as from construction equipment operation, clamshell digging, concrete tremie pour, or work inside a cofferdam, shall be handled separately from stormwater at the site.

(d) Other disposal options, depending on site constraints, may include, by way of example: 1) transport off-site in vehicle, such as a vacuum flush truck, for legal disposal in a manner that does not pollute state waters, 2) on-site treatment using chemical treatment or other suitable treatment technologies.

6.2.11 ELEMENT #11 - MAINTAIN BMPS

(a) All temporary and permanent erosion and sediment control BMPs shall be maintained and repaired as needed to assure continued performance of their intended function. All maintenance and repair shall be conducted in accordance with BMPs.

(b) Sediment control BMPs shall be inspected weekly or after a runoff-producing storm event during the dry season and daily during the wet season. All projects that disturb an area greater than one acre shall have a certified erosion control lead available to the site. This erosion control lead shall be responsible to provide overview of ongoing day to day erosion control requirements. The erosion control lead shall (within 24 hours) report to the city and department of ecology any site discharges that exceed state water quality standards that have or are likely to have entered waters of the state.

(c) All temporary erosion and sediment control BMPs shall be removed within 30 days after final site stabilization is achieved or after the temporary BMPs are no longer needed. Trapped sediment shall be removed or stabilized on site. Disturbed soil areas resulting from removal of BMPs or vegetation shall be permanently stabilized.

6.2.12 ELEMENT #12 - MANAGE THE PROJECT

(a) Phasing of construction - development projects shall be phased where feasible in order to prevent, to the maximum extent practicable, the transport of sediment from the development site during construction. Revegetation of exposed areas and maintenance of that vegetation shall be an integral part of the clearing activities for any phase.

(b) When establishing these permitted clearing and grading areas, consideration should be given to minimizing removal of existing trees and minimizing disturbance/compaction of native soils except as needed for building purposes. Permitted clearing and grading areas and any other areas required to preserve critical or sensitive areas, buffers, native growth protection easements, or tree retention areas, shall be delineated on the site plans and the development site.

(c) Coordination with utilities and other contractors - the primary project proponent shall evaluate, with input from utilities and other contractors, the stormwater management requirements for the entire project, including the utilities, when preparing the construction SWPPP.

(d) Inspection and monitoring - all BMPs shall be inspected, maintained, and repaired as needed to assure continued performance of their intended function.

(e) For any project disturbing more than one acre, a certified professional in erosion and sediment control shall be identified in the construction SWPPP and shall be on-site or on-call at all times. Certification may be through the Washington state department of transportation/associated general contractors (WSDOT/AGC) construction site erosion and sediment control certification program or any equivalent local or national certification and/or training program, in the city's discretion.

(f) Whenever inspection and/or monitoring reveals that the BMPs identified in the construction SWPPP are inadequate, due to the actual discharge of or potential to discharge a significant amount of any pollutant, the SWPPP shall be modified, as appropriate, in a timely manner.

(g) Maintenance of the construction SWPPP - the construction SWPPP shall be retained on-site. The construction SWPPP shall be modified whenever there is a significant change in the design, construction, operation, or maintenance of any BMP.

6.2.13 ELEMENT #13 – PROTECT LOW IMPACT DEVELOPMENT BMP'S

The project proposes to install topsoil in accordance with BMP T5.13 Post Construction Soil Quality and Depth. Upon placement of the BMP the owner shall avoid vehicle traffic in the area other than specific lawn / landscape maintenance equipment.

6.3 REQUIREMENT NO. 3 – SOURCE CONTROL OF POLLUTION

The following construction site source control Best Management Practices (BMP's) have been selected as requirements on this project, obtained from the WSDOE Manual, Volume 2:

- BMP C101: Preserving Natural Vegetation
 - BMP C105: Stabilized Construction Entrance
 - BMP C120: Temporary & Permanent Seeding
 - BMP C125: Topsoiling
 - BMP C140: Dust Control
 - BMP C151: Concrete Handling
 - BMP C152: Sawcutting and Surface Pollution Prevention
-

The following runoff conveyance and treatment BMPs are required to be implemented during the construction of the project to minimize erosion and sedimentation impacts associated with construction activities:

- BMP C209: Rock Lining Outlet Protection
- BMP C220: Storm Drain Inlet Protection

Detailed descriptions of each of the above BMP's are included in Appendix 8.7 Construction BMP's. The above construction source control, runoff conveyance, and treatment BMP's are the minimum requirements for anticipated site conditions during the construction period. Additional BMP's may be required at the discretion of the engineer for unexpected storm events or site conditions encountered during construction that may include but are not limited to the following:

- BMP C107: Construction Road/Parking Area Stabilization
- BMP C121: Mulching
- BMP C122: Nets & Blankets
- BMP C124: Sodding
- BMP C130: Surface Roughening
- BMP C150: Materials on Hand
- BMP C200: Interceptor Dike and Swale
- BMP C201: Grass Lined Channels
- BMP C202: Channel Lining
- BMP C205: Sub-Surface Drains
- BMP C233: Silt Fence
- BMP C235: Straw Wattles
- BMP C251: Construction Storm water Filtration

Upon completion of construction, the following pollutant source control BMPs are recommended for implementation associated with the management and maintenance of the development, obtained from the DOE Manual, Volume 4:

- S406 BMPs for Streets and Highways
- S410 BMPs for Illicit Connections to Storm Drains
- S411 BMPs for Landscape & Vegetation Management
- S415 BMPs for Maintenance of Public and Private utility Corridors and Facilities
- S417 BMPs for Maintenance of Storm Water Drainage and Treatment Systems
- S453 BMPs for Formation of a Pollution Prevention Team
- S454 BMPs for Preventative Maintenance / Good Housekeeping
- S455 BMPs for Spill Prevention and Cleanup
- S456 BMPs for Employee Training
- S457 BMPs for Inspections
- S458 BMPs for Record Keeping

Detailed descriptions of each of the above Pollution Source-Specific BMPs are included in the WSDOE Stormwater Management Manual for Western Washington, 2019 edition.

6.4 REQUIREMENT NO. 4 – PRESERVATION OF NATURAL DRAINAGE SYSTEMS AND OUTFALLS

All existing stormwater runoff from the undeveloped property flows directly to Chuckanut Bay. All surface water runoff from the development will continue to flow to Chuckanut Bay.

6.5 REQUIREMENT NO. 5 – ON-SITE STORM WATER MANAGEMENT

The project requires compliance with minimum requirements 1 – 9 and use On-Site Stormwater Management BMP's from List 2 for each surface type.

The following provides a list of surfaces and considers BMP's for each surface type in order listed in the DOE Manual:

Lawn/Landscape Areas: Lawn/Landscape areas will implement BMP T5.13 – Post Construction Soil Quality and Depth. BMP-T5.13 provides increased treatment of pollutants and sediments and reduces pollution through prevention as the need for some landscaping chemicals is reduced. Runoff generated onsite will be conveyed to the appropriate facilities and treated if necessary. See Appendix 8.9 for the BMP T5.14 requirements.

Impervious Surface Areas: The feasibility of on-site Stormwater Management BMPs has been considered and are explained further below:

Other Hard Surfaces:

1. **Full Dispersion:** Full Dispersion is considered infeasible for the project based on the minimum design requirements outlined in BMP T5.30 Full Dispersion, specific infeasibility criteria applicable to the project included:
 - a. *“If they are within a threshold discharge area that is or will be more than 65% forested and less than 10% impervious... with vegetated flow paths of 100 feet or more through the native vegetation preserved area”* No such vegetative area or flow path exists on the project site.
2. **Permeable Pavement:** Permeable Pavement is considered infeasible for the project based on the Infeasibility Criteria Detailed in BMP T5.15 Permeable Pavements, Specific infeasibility criteria applicable to the project include:
 - a. Due to low permeability and silty clays on site infiltration is not feasible. Separation requirements from the bottom of the permeable pavement section to impervious soil is not achievable.
3. **Bioretention:** Bioretention is considered infeasible for the project based on the Infeasibility Criteria Detailed in BMP T7.30 Bioretention Cells, Swales, and Planter boxes, specific infeasibility criteria applicable to the project include:
 - a. *“Where the minimum vertical separation of 1-foot to the seasonal high-water table, bedrock, or other impervious layer would not be achieved below bioretention...”* The native soils onsite are considered impervious and unsuitable for infiltration.
4. **Sheet Flow Dispersion:** Sheet Flow Dispersion and Concentrated Flow Dispersion is considered infeasible for the project based on the minimum design requirements outlined in BMP T5.11 Concentrated Flow Dispersion, Specific infeasibility criteria applicable to the project include:
 - a. *“Maintain a vegetated flow path of at least 50 feet between the discharge point and any property line, structure, steep slope, stream, lake, wetland, or impervious area”* No such vegetative area or flow path exists on the project.

6.6 REQUIREMENT NO. 6 – RUNOFF TREATMENT

This project is required to meet basic water quality treatment standards per BMC 15.42. However, this project has elected to increase the level of stormwater treatment and meet the enhanced treatment level standard.

The site improvements will meet Enhanced Treatment for this project with the use of modular wetland devices. The treatment method and sizing calculations are detailed in Section 5.5

6.7 REQUIREMENT NO. 7 – FLOW CONTROL

Flow control for the Chuckanut Bay TDA is not required due to direct discharge to a flow control exempt water body. S. Clarkwood Dr TDA will not require flow control as less than 10,000 SF of new plus replaced impervious surfacing is proposed. The Viewcrest Rd TDA does require flow control as more than 10,000 SF of new plus replaced impervious surfacing is proposed in the TDA. See Section 5.2 for more detail.

6.8 REQUIREMENT NO. 8 – WETLANDS PROTECTION

Three wetlands exist on the site that were delineated by Northwest Ecological Services in September 2020. All three wetlands are located in the eastern portion of the site, and will be protected upon project completion. The critical areas summary compiled by Northwest Ecological Services can be found in Appendix 8.9.

6.9 REQUIREMENT NO. 9 – OPERATION AND MAINTENANCE

This project will construct both private and public stormwater infrastructure. Operation and maintenance of publicly owned storm water management facilities shall be the responsibility of the City of Bellingham. Since the City of Bellingham has a City-wide maintenance program for all of their stormwater drainage systems, we assume that the facilities constructed as a part of this project will be maintained using the current maintenance processes and procedures by the City of Bellingham.

Private stormwater management facilities will be maintained by the Homeowner's Association in accordance with the maintenance guidelines specified in the Washington State Department of Ecology Stormwater Management Manual, 2019 edition, Volume V, Appendix A.

A complete operations and maintenance manual will be prepared in conjunction with future construction permit applications for all privately owned stormwater facilities. It is assumed that standard City-owned infrastructure will be maintained in accordance with standard City of Bellingham maintenance procedures.

The above ground stormwater outfall pipe and energy dissipater is a non-standard stormwater element that will be owned and maintained by the City. Above ground stormwater systems are relatively maintenance free due to the steep slope of the pipe system. However, the energy dissipater at the end of the pipe may require routine inspections and clearing of accumulated debris. It is assumed that maintenance personnel will be able to access the above ground pipe system and energy dissipater to conduct the necessary maintenance activities.

7 PRINCIPAL FINDINGS AND RECOMMENDATIONS

Detailed analysis has shown that all drainage requirements can be met for the proposed project site. Storm water treatment requirements for the developed project shall be accomplished with the use of a modular wetland device. All storm water management associated with the proposed project will comply with the BMC 15.42 and all applicable minimum requirements outlined in the DOE Manual.

8.2 NRCS SOILS REPORT



United States
Department of
Agriculture

NRCS

Natural
Resources
Conservation
Service

A product of the National
Cooperative Soil Survey,
a joint effort of the United
States Department of
Agriculture and other
Federal agencies, State
agencies including the
Agricultural Experiment
Stations, and local
participants

Custom Soil Resource Report for Whatcom County Area, Washington



Preface

Soil surveys contain information that affects land use planning in survey areas. They highlight soil limitations that affect various land uses and provide information about the properties of the soils in the survey areas. Soil surveys are designed for many different users, including farmers, ranchers, foresters, agronomists, urban planners, community officials, engineers, developers, builders, and home buyers. Also, conservationists, teachers, students, and specialists in recreation, waste disposal, and pollution control can use the surveys to help them understand, protect, or enhance the environment.

Various land use regulations of Federal, State, and local governments may impose special restrictions on land use or land treatment. Soil surveys identify soil properties that are used in making various land use or land treatment decisions. The information is intended to help the land users identify and reduce the effects of soil limitations on various land uses. The landowner or user is responsible for identifying and complying with existing laws and regulations.

Although soil survey information can be used for general farm, local, and wider area planning, onsite investigation is needed to supplement this information in some cases. Examples include soil quality assessments (<http://www.nrcs.usda.gov/wps/portal/nrcs/main/soils/health/>) and certain conservation and engineering applications. For more detailed information, contact your local USDA Service Center (<https://offices.sc.egov.usda.gov/locator/app?agency=nrcs>) or your NRCS State Soil Scientist (http://www.nrcs.usda.gov/wps/portal/nrcs/detail/soils/contactus/?cid=nrcs142p2_053951).

Great differences in soil properties can occur within short distances. Some soils are seasonally wet or subject to flooding. Some are too unstable to be used as a foundation for buildings or roads. Clayey or wet soils are poorly suited to use as septic tank absorption fields. A high water table makes a soil poorly suited to basements or underground installations.

The National Cooperative Soil Survey is a joint effort of the United States Department of Agriculture and other Federal agencies, State agencies including the Agricultural Experiment Stations, and local agencies. The Natural Resources Conservation Service (NRCS) has leadership for the Federal part of the National Cooperative Soil Survey.

Information about soils is updated periodically. Updated information is available through the NRCS Web Soil Survey, the site for official soil survey information.

The U.S. Department of Agriculture (USDA) prohibits discrimination in all its programs and activities on the basis of race, color, national origin, age, disability, and where applicable, sex, marital status, familial status, parental status, religion, sexual orientation, genetic information, political beliefs, reprisal, or because all or a part of an individual's income is derived from any public assistance program. (Not all prohibited bases apply to all programs.) Persons with disabilities who require

alternative means for communication of program information (Braille, large print, audiotape, etc.) should contact USDA's TARGET Center at (202) 720-2600 (voice and TDD). To file a complaint of discrimination, write to USDA, Director, Office of Civil Rights, 1400 Independence Avenue, S.W., Washington, D.C. 20250-9410 or call (800) 795-3272 (voice) or (202) 720-6382 (TDD). USDA is an equal opportunity provider and employer.

Contents

Preface	2
How Soil Surveys Are Made	5
Soil Map	8
Soil Map.....	9
Legend.....	10
Map Unit Legend.....	11
Map Unit Descriptions.....	11
Whatcom County Area, Washington.....	13
52—Everett-Urban land complex, 5 to 20 percent slopes.....	13
110—Nati loam, 30 to 60 percent slopes.....	14
References	16

How Soil Surveys Are Made

Soil surveys are made to provide information about the soils and miscellaneous areas in a specific area. They include a description of the soils and miscellaneous areas and their location on the landscape and tables that show soil properties and limitations affecting various uses. Soil scientists observed the steepness, length, and shape of the slopes; the general pattern of drainage; the kinds of crops and native plants; and the kinds of bedrock. They observed and described many soil profiles. A soil profile is the sequence of natural layers, or horizons, in a soil. The profile extends from the surface down into the unconsolidated material in which the soil formed or from the surface down to bedrock. The unconsolidated material is devoid of roots and other living organisms and has not been changed by other biological activity.

Currently, soils are mapped according to the boundaries of major land resource areas (MLRAs). MLRAs are geographically associated land resource units that share common characteristics related to physiography, geology, climate, water resources, soils, biological resources, and land uses (USDA, 2006). Soil survey areas typically consist of parts of one or more MLRA.

The soils and miscellaneous areas in a survey area occur in an orderly pattern that is related to the geology, landforms, relief, climate, and natural vegetation of the area. Each kind of soil and miscellaneous area is associated with a particular kind of landform or with a segment of the landform. By observing the soils and miscellaneous areas in the survey area and relating their position to specific segments of the landform, a soil scientist develops a concept, or model, of how they were formed. Thus, during mapping, this model enables the soil scientist to predict with a considerable degree of accuracy the kind of soil or miscellaneous area at a specific location on the landscape.

Commonly, individual soils on the landscape merge into one another as their characteristics gradually change. To construct an accurate soil map, however, soil scientists must determine the boundaries between the soils. They can observe only a limited number of soil profiles. Nevertheless, these observations, supplemented by an understanding of the soil-vegetation-landscape relationship, are sufficient to verify predictions of the kinds of soil in an area and to determine the boundaries.

Soil scientists recorded the characteristics of the soil profiles that they studied. They noted soil color, texture, size and shape of soil aggregates, kind and amount of rock fragments, distribution of plant roots, reaction, and other features that enable them to identify soils. After describing the soils in the survey area and determining their properties, the soil scientists assigned the soils to taxonomic classes (units). Taxonomic classes are concepts. Each taxonomic class has a set of soil characteristics with precisely defined limits. The classes are used as a basis for comparison to classify soils systematically. Soil taxonomy, the system of taxonomic classification used in the United States, is based mainly on the kind and character of soil properties and the arrangement of horizons within the profile. After the soil

Custom Soil Resource Report

scientists classified and named the soils in the survey area, they compared the individual soils with similar soils in the same taxonomic class in other areas so that they could confirm data and assemble additional data based on experience and research.

The objective of soil mapping is not to delineate pure map unit components; the objective is to separate the landscape into landforms or landform segments that have similar use and management requirements. Each map unit is defined by a unique combination of soil components and/or miscellaneous areas in predictable proportions. Some components may be highly contrasting to the other components of the map unit. The presence of minor components in a map unit in no way diminishes the usefulness or accuracy of the data. The delineation of such landforms and landform segments on the map provides sufficient information for the development of resource plans. If intensive use of small areas is planned, onsite investigation is needed to define and locate the soils and miscellaneous areas.

Soil scientists make many field observations in the process of producing a soil map. The frequency of observation is dependent upon several factors, including scale of mapping, intensity of mapping, design of map units, complexity of the landscape, and experience of the soil scientist. Observations are made to test and refine the soil-landscape model and predictions and to verify the classification of the soils at specific locations. Once the soil-landscape model is refined, a significantly smaller number of measurements of individual soil properties are made and recorded. These measurements may include field measurements, such as those for color, depth to bedrock, and texture, and laboratory measurements, such as those for content of sand, silt, clay, salt, and other components. Properties of each soil typically vary from one point to another across the landscape.

Observations for map unit components are aggregated to develop ranges of characteristics for the components. The aggregated values are presented. Direct measurements do not exist for every property presented for every map unit component. Values for some properties are estimated from combinations of other properties.

While a soil survey is in progress, samples of some of the soils in the area generally are collected for laboratory analyses and for engineering tests. Soil scientists interpret the data from these analyses and tests as well as the field-observed characteristics and the soil properties to determine the expected behavior of the soils under different uses. Interpretations for all of the soils are field tested through observation of the soils in different uses and under different levels of management. Some interpretations are modified to fit local conditions, and some new interpretations are developed to meet local needs. Data are assembled from other sources, such as research information, production records, and field experience of specialists. For example, data on crop yields under defined levels of management are assembled from farm records and from field or plot experiments on the same kinds of soil.

Predictions about soil behavior are based not only on soil properties but also on such variables as climate and biological activity. Soil conditions are predictable over long periods of time, but they are not predictable from year to year. For example, soil scientists can predict with a fairly high degree of accuracy that a given soil will have a high water table within certain depths in most years, but they cannot predict that a high water table will always be at a specific level in the soil on a specific date.

After soil scientists located and identified the significant natural bodies of soil in the survey area, they drew the boundaries of these bodies on aerial photographs and

Custom Soil Resource Report

identified each as a specific map unit. Aerial photographs show trees, buildings, fields, roads, and rivers, all of which help in locating boundaries accurately.

Soil Map

The soil map section includes the soil map for the defined area of interest, a list of soil map units on the map and extent of each map unit, and cartographic symbols displayed on the map. Also presented are various metadata about data used to produce the map, and a description of each soil map unit.

Custom Soil Resource Report Soil Map



Map Scale: 1:4,360 if printed on A landscape (11" x 8.5") sheet.

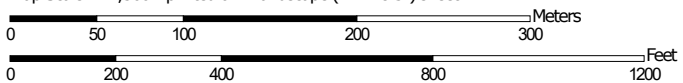

Map projection: Web Mercator Corner coordinates: WGS84 Edge tics: UTM Zone 10N WGS84

MAP LEGEND

Area of Interest (AOI)

 Area of Interest (AOI)

Soils

 Soil Map Unit Polygons

 Soil Map Unit Lines

 Soil Map Unit Points

Special Point Features





-  Blowout
-  Borrow Pit
-  Clay Spot
-  Closed Depression
-  Gravel Pit
-  Gravelly Spot
-  Landfill
-  Lava Flow
-  Marsh or swamp
-  Mine or Quarry
-  Miscellaneous Water
-  Perennial Water
-  Rock Outcrop
-  Saline Spot
-  Sandy Spot
-  Severely Eroded Spot
-  Sinkhole
-  Slide or Slip
-  Sodic Spot

-  Spoil Area
-  Stony Spot
-  Very Stony Spot
-  Wet Spot
-  Other
-  Special Line Features

Water Features

 Streams and Canals

Transportation

-  Rails
-  Interstate Highways
-  US Routes
-  Major Roads
-  Local Roads

Background

 Aerial Photography

MAP INFORMATION

The soil surveys that comprise your AOI were mapped at 1:24,000.

Warning: Soil Map may not be valid at this scale.

Enlargement of maps beyond the scale of mapping can cause misunderstanding of the detail of mapping and accuracy of soil line placement. The maps do not show the small areas of contrasting soils that could have been shown at a more detailed scale.

Please rely on the bar scale on each map sheet for map measurements.

Source of Map: Natural Resources Conservation Service
 Web Soil Survey URL:
 Coordinate System: Web Mercator (EPSG:3857)

Maps from the Web Soil Survey are based on the Web Mercator projection, which preserves direction and shape but distorts distance and area. A projection that preserves area, such as the Albers equal-area conic projection, should be used if more accurate calculations of distance or area are required.

This product is generated from the USDA-NRCS certified data as of the version date(s) listed below.

Soil Survey Area: Whatcom County Area, Washington
 Survey Area Data: Version 20, Jun 4, 2020

Soil map units are labeled (as space allows) for map scales 1:50,000 or larger.

Date(s) aerial images were photographed: Jul 9, 2010—Aug 28, 2011

The orthophoto or other base map on which the soil lines were compiled and digitized probably differs from the background imagery displayed on these maps. As a result, some minor shifting of map unit boundaries may be evident.

Map Unit Legend

Map Unit Symbol	Map Unit Name	Acres in AOI	Percent of AOI
52	Everett-Urban land complex, 5 to 20 percent slopes	21.0	26.1%
110	Nati loam, 30 to 60 percent slopes	33.4	41.4%
Totals for Area of Interest		80.6	100.0%

Map Unit Descriptions

The map units delineated on the detailed soil maps in a soil survey represent the soils or miscellaneous areas in the survey area. The map unit descriptions, along with the maps, can be used to determine the composition and properties of a unit.

A map unit delineation on a soil map represents an area dominated by one or more major kinds of soil or miscellaneous areas. A map unit is identified and named according to the taxonomic classification of the dominant soils. Within a taxonomic class there are precisely defined limits for the properties of the soils. On the landscape, however, the soils are natural phenomena, and they have the characteristic variability of all natural phenomena. Thus, the range of some observed properties may extend beyond the limits defined for a taxonomic class. Areas of soils of a single taxonomic class rarely, if ever, can be mapped without including areas of other taxonomic classes. Consequently, every map unit is made up of the soils or miscellaneous areas for which it is named and some minor components that belong to taxonomic classes other than those of the major soils.

Most minor soils have properties similar to those of the dominant soil or soils in the map unit, and thus they do not affect use and management. These are called noncontrasting, or similar, components. They may or may not be mentioned in a particular map unit description. Other minor components, however, have properties and behavioral characteristics divergent enough to affect use or to require different management. These are called contrasting, or dissimilar, components. They generally are in small areas and could not be mapped separately because of the scale used. Some small areas of strongly contrasting soils or miscellaneous areas are identified by a special symbol on the maps. If included in the database for a given area, the contrasting minor components are identified in the map unit descriptions along with some characteristics of each. A few areas of minor components may not have been observed, and consequently they are not mentioned in the descriptions, especially where the pattern was so complex that it was impractical to make enough observations to identify all the soils and miscellaneous areas on the landscape.

The presence of minor components in a map unit in no way diminishes the usefulness or accuracy of the data. The objective of mapping is not to delineate pure taxonomic classes but rather to separate the landscape into landforms or landform segments that have similar use and management requirements. The delineation of such segments on the map provides sufficient information for the development of resource plans. If intensive use of small areas is planned, however,

Custom Soil Resource Report

onsite investigation is needed to define and locate the soils and miscellaneous areas.

An identifying symbol precedes the map unit name in the map unit descriptions. Each description includes general facts about the unit and gives important soil properties and qualities.

Soils that have profiles that are almost alike make up a *soil series*. Except for differences in texture of the surface layer, all the soils of a series have major horizons that are similar in composition, thickness, and arrangement.

Soils of one series can differ in texture of the surface layer, slope, stoniness, salinity, degree of erosion, and other characteristics that affect their use. On the basis of such differences, a soil series is divided into *soil phases*. Most of the areas shown on the detailed soil maps are phases of soil series. The name of a soil phase commonly indicates a feature that affects use or management. For example, Alpha silt loam, 0 to 2 percent slopes, is a phase of the Alpha series.

Some map units are made up of two or more major soils or miscellaneous areas. These map units are complexes, associations, or undifferentiated groups.

A *complex* consists of two or more soils or miscellaneous areas in such an intricate pattern or in such small areas that they cannot be shown separately on the maps. The pattern and proportion of the soils or miscellaneous areas are somewhat similar in all areas. Alpha-Beta complex, 0 to 6 percent slopes, is an example.

An *association* is made up of two or more geographically associated soils or miscellaneous areas that are shown as one unit on the maps. Because of present or anticipated uses of the map units in the survey area, it was not considered practical or necessary to map the soils or miscellaneous areas separately. The pattern and relative proportion of the soils or miscellaneous areas are somewhat similar. Alpha-Beta association, 0 to 2 percent slopes, is an example.

An *undifferentiated group* is made up of two or more soils or miscellaneous areas that could be mapped individually but are mapped as one unit because similar interpretations can be made for use and management. The pattern and proportion of the soils or miscellaneous areas in a mapped area are not uniform. An area can be made up of only one of the major soils or miscellaneous areas, or it can be made up of all of them. Alpha and Beta soils, 0 to 2 percent slopes, is an example.

Some surveys include *miscellaneous areas*. Such areas have little or no soil material and support little or no vegetation. Rock outcrop is an example.

Whatcom County Area, Washington

52—Everett-Urban land complex, 5 to 20 percent slopes

Map Unit Setting

National map unit symbol: 2j52
Elevation: 50 to 250 feet
Mean annual precipitation: 30 to 50 inches
Mean annual air temperature: 50 degrees F
Frost-free period: 180 days
Farmland classification: Not prime farmland

Map Unit Composition

Everett and similar soils: 50 percent
Urban land: 30 percent
Minor components: 20 percent
Estimates are based on observations, descriptions, and transects of the mapunit.

Description of Everett

Setting

Landform: Moraines, terraces
Parent material: Loess and volcanic ash over glacial outwash

Typical profile

H1 - 0 to 6 inches: gravelly ashy sandy loam
H2 - 6 to 13 inches: gravelly ashy sandy loam
H3 - 13 to 25 inches: very gravelly sandy loam
H4 - 25 to 41 inches: very gravelly loamy sand
H5 - 41 to 60 inches: very gravelly sand

Properties and qualities

Slope: 5 to 20 percent
Depth to restrictive feature: 40 to 60 inches to densic material
Drainage class: Somewhat excessively drained
Capacity of the most limiting layer to transmit water (Ksat): Very low to moderately low (0.00 to 0.06 in/hr)
Depth to water table: About 39 to 59 inches
Frequency of flooding: None
Frequency of ponding: None
Available water supply, 0 to 60 inches: Low (about 4.3 inches)

Interpretive groups

Land capability classification (irrigated): None specified
Land capability classification (nonirrigated): 3e
Hydrologic Soil Group: B
Forage suitability group: Droughty Soils (G002XN402WA)
Other vegetative classification: Droughty Soils (G002XN402WA)
Hydric soil rating: No

Description of Urban Land

Interpretive groups

Land capability classification (irrigated): None specified
Land capability classification (nonirrigated): 8
Hydric soil rating: No

Minor Components

Sehome

Percent of map unit: 5 percent
Hydric soil rating: No

Squalicum

Percent of map unit: 5 percent
Hydric soil rating: No

Chuckanut

Percent of map unit: 4 percent
Hydric soil rating: No

Whatcom

Percent of map unit: 3 percent
Hydric soil rating: No

Labounty, undrained

Percent of map unit: 3 percent
Landform: Depressions
Other vegetative classification: Wet Soils (G002XN102WA)
Hydric soil rating: Yes

110—Nati loam, 30 to 60 percent slopes

Map Unit Setting

National map unit symbol: 2j0z
Elevation: 100 to 1,600 feet
Mean annual precipitation: 35 to 50 inches
Mean annual air temperature: 46 to 48 degrees F
Frost-free period: 140 to 170 days
Farmland classification: Not prime farmland

Map Unit Composition

Nati and similar soils: 85 percent
Minor components: 10 percent
Estimates are based on observations, descriptions, and transects of the mapunit.

Description of Nati

Setting

Landform: Ridges, hillslopes
Landform position (two-dimensional): Backslope
Parent material: Volcanic ash and colluvium and slope alluvium derived from sandstone and siltstone and glacial drift

Typical profile

H1 - 0 to 10 inches: ashy loam
H2 - 10 to 38 inches: ashy loam

Custom Soil Resource Report

H3 - 38 to 42 inches: weathered bedrock

Properties and qualities

Slope: 30 to 60 percent

Depth to restrictive feature: More than 80 inches; 20 to 40 inches to paralithic bedrock

Drainage class: Well drained

Capacity of the most limiting layer to transmit water (Ksat): Moderately high to high (0.57 to 1.98 in/hr)

Depth to water table: More than 80 inches

Frequency of flooding: None

Frequency of ponding: None

Available water supply, 0 to 60 inches: Low (about 5.4 inches)

Interpretive groups

Land capability classification (irrigated): None specified

Land capability classification (nonirrigated): 7e

Hydrologic Soil Group: C

Hydric soil rating: No

Minor Components

Squalicum

Percent of map unit: 5 percent

Hydric soil rating: No

Shalcar, undrained

Percent of map unit: 1 percent

Landform: Flood plains

Other vegetative classification: Wet Soils (G002XN102WA)

Hydric soil rating: Yes

Chuckanut

Percent of map unit: 1 percent

Hydric soil rating: No

Bellingham, undrained

Percent of map unit: 1 percent

Landform: Depressions

Other vegetative classification: Wet Soils (G002XN102WA)

Hydric soil rating: Yes

Sehome

Percent of map unit: 1 percent

Hydric soil rating: No

Comar

Percent of map unit: 1 percent

Hydric soil rating: No

References

- American Association of State Highway and Transportation Officials (AASHTO). 2004. Standard specifications for transportation materials and methods of sampling and testing. 24th edition.
- American Society for Testing and Materials (ASTM). 2005. Standard classification of soils for engineering purposes. ASTM Standard D2487-00.
- Cowardin, L.M., V. Carter, F.C. Golet, and E.T. LaRoe. 1979. Classification of wetlands and deep-water habitats of the United States. U.S. Fish and Wildlife Service FWS/OBS-79/31.
- Federal Register. July 13, 1994. Changes in hydric soils of the United States.
- Federal Register. September 18, 2002. Hydric soils of the United States.
- Hurt, G.W., and L.M. Vasilas, editors. Version 6.0, 2006. Field indicators of hydric soils in the United States.
- National Research Council. 1995. Wetlands: Characteristics and boundaries.
- Soil Survey Division Staff. 1993. Soil survey manual. Soil Conservation Service. U.S. Department of Agriculture Handbook 18. http://www.nrcs.usda.gov/wps/portal/nrcs/detail/national/soils/?cid=nrcs142p2_054262
- Soil Survey Staff. 1999. Soil taxonomy: A basic system of soil classification for making and interpreting soil surveys. 2nd edition. Natural Resources Conservation Service, U.S. Department of Agriculture Handbook 436. http://www.nrcs.usda.gov/wps/portal/nrcs/detail/national/soils/?cid=nrcs142p2_053577
- Soil Survey Staff. 2010. Keys to soil taxonomy. 11th edition. U.S. Department of Agriculture, Natural Resources Conservation Service. http://www.nrcs.usda.gov/wps/portal/nrcs/detail/national/soils/?cid=nrcs142p2_053580
- Tiner, R.W., Jr. 1985. Wetlands of Delaware. U.S. Fish and Wildlife Service and Delaware Department of Natural Resources and Environmental Control, Wetlands Section.
- United States Army Corps of Engineers, Environmental Laboratory. 1987. Corps of Engineers wetlands delineation manual. Waterways Experiment Station Technical Report Y-87-1.
- United States Department of Agriculture, Natural Resources Conservation Service. National forestry manual. http://www.nrcs.usda.gov/wps/portal/nrcs/detail/soils/home/?cid=nrcs142p2_053374
- United States Department of Agriculture, Natural Resources Conservation Service. National range and pasture handbook. <http://www.nrcs.usda.gov/wps/portal/nrcs/detail/national/landuse/rangepasture/?cid=stelprdb1043084>

Custom Soil Resource Report

United States Department of Agriculture, Natural Resources Conservation Service. National soil survey handbook, title 430-VI. http://www.nrcs.usda.gov/wps/portal/nrcs/detail/soils/scientists/?cid=nrcs142p2_054242

United States Department of Agriculture, Natural Resources Conservation Service. 2006. Land resource regions and major land resource areas of the United States, the Caribbean, and the Pacific Basin. U.S. Department of Agriculture Handbook 296. http://www.nrcs.usda.gov/wps/portal/nrcs/detail/national/soils/?cid=nrcs142p2_053624

United States Department of Agriculture, Soil Conservation Service. 1961. Land capability classification. U.S. Department of Agriculture Handbook 210. http://www.nrcs.usda.gov/Internet/FSE_DOCUMENTS/nrcs142p2_052290.pdf

8.3 GEOLOGIC FEASIBILITY INVESTIGATION

**GEOTECHNICAL INVESTIGATION
& GEOHAZARD REPORT
JONES EDGEMOOR ESTATE
PROPOSED 38-LOT PLAT DEVELOPMENT
VIEWCREST ROAD, BELLINGHAM, WA**

Submitted to Ann C Jones, Family LP
November 3, 2021



Submitted by:
ELEMENT Solutions
909 Squaticum Way, Suite 111
Bellingham, WA 98225
T | 360.671.9172
info@elementsolutions.org



November 3, 2021

To: Ann C Jones, Family LP
807 Chuckanut Shore Road, Bellingham, WA 98229

Subject: **Geotechnical Investigation & Geohazard Assessment**
Proposed 38-Lot Plat - Jones Edgemoor Estate
Viewcrest Road, Bellingham, WA

Dear Ms. Jones,

Element Solutions (Element) is pleased to present the following Geotechnical Investigation for the above referenced project and site. This report was compiled using information provided by the project team, desktop review of public information, field reconnaissance with slope observation, subsurface geotechnical explorations, laboratory testing, review and analysis of conditions encountered, and the professional judgment of our geotechnical professionals.

The work plan generally included review of the study area and mapped geologic conditions, field reconnaissance and visual assessment of existing site conditions, and a subsurface investigation that entailed the logging and evaluation of twenty-six (26) exploratory test pits. Reconnaissance for observation of slope conditions, interpretation of geologic hazards, and assessment of exposed bedrock characteristics was performed on several dates during the course of this study. Test pits were observed on June 30 and July 1, 2020, at locations dispersed throughout the upland areas of the site interior as current access allowed. Additional explorations for utility construction planning were completed along Sea Pines Road on November 13, 2020, including two (2) machine test pits and two (2) hand auger borings. Our interpretations and conclusions regarding geologic hazards and subsurface conditions across the study area, based on work completed to date, are summarized in the following report.

This report is intended to provide the project team with site-wide geologic information, project feasibility commentary, and relevant geotechnical recommendations to inform project decisions, conceptual planning, and engineering design considerations for the proposed plat at the Jones-Edgemoor Estate property.

Thank you for the opportunity to work on this project. Should you have any questions regarding this report, please contact us at (360) 671-9172. Element Solutions is a wholly owned subsidiary of Pacific Surveying & Engineering.

Sincerely,



John R Gillaspay, LEG, M.S.
Environmental Services Manager
ELEMENT SOLUTIONS

Table of Contents

Table of Contents	1
1 Introduction	1
1.1 General Overview.....	1
1.2 Project Understanding	1
1.3 Purpose and Summary of Scope.....	2
1.4 Assumptions and Limitations	2
2 Desktop Review and Interpretation	3
2.1 Methods.....	3
2.2 Location and Physiography.....	3
2.3 Geologic Background.....	3
2.3.1 NRCS Web Soil Survey	4
2.4 Geologic Hazard Commentary.....	5
2.4.1 Slope Gradient Review	5
2.4.2 Special Hazard Areas	6
3 Geotechnical Explorations	7
3.1 Methods.....	7
3.1.1 Subsurface Investigation	7
3.2 Subsurface Soil Conditions	7
3.2.1 Laboratory Testing Results	10
3.3 Groundwater Conditions.....	11
3.4 Additional Explorations – Sea Pines Road	11
3.4.1 Methods.....	11
3.4.2 Subsurface Conditions.....	12
3.4.3 Utility Construction and Bedrock Profile	12
4 Geologic Hazards & Slope Stability	13
4.1 Review Methodology	13
4.1.1 Stability Factors and Areas of Potential Hazard.....	13
4.2 Slope Review & Observations.....	14
4.2.1 Northwest Slope.....	14
4.2.2 Western and Central Slopes	15
4.2.3 Southwest Slopes	16
4.3 Bedrock Outcrops & Structures.....	17
4.3.1 Bedding	17
4.3.2 Joint Patterns	18
4.3.3 Rock Face Stability.....	18
4.3.4 Rock Fall Characteristics	20
4.4 Geohazard Review Findings & Recommendations	20
4.4.1 Conclusions on Slope Stability for Development	20
4.4.2 Preliminary Building Setback & Avoidance Recommendations	21
4.4.3 Need for Lot-Specific Reviews	23

5	Conclusions and Recommendations.....	24
5.1	Project Feasibility Discussion.....	24
5.1.1	Foundation Feasibility Commentary.....	24
5.1.2	Road & Utility Construction Feasibility.....	25
5.1.3	Stormwater Infiltration Design Feasibility.....	25
5.2	Seismic Design and Liquefaction Potential.....	26
5.2.1	Seismic Design Coefficients.....	26
5.2.2	Liquefaction Susceptibility.....	27
5.3	Foundation Design and Construction.....	27
5.3.1	Bearing Capacity.....	28
5.3.2	Lateral Resistance.....	28
5.3.3	Foundation Drainage.....	28
5.4	Retaining Wall Foundations.....	29
5.4.1	Lateral Earth Pressures.....	29
5.4.2	Wall Construction Recommendations.....	30
5.5	Slab-On-Grade Floors.....	30
5.5.1	Slab Preparation and Construction.....	30
5.5.2	Slab Drainage and Moisture Control.....	31
5.6	Pavement Recommendations.....	31
5.6.1	Pavement Design Considerations.....	31
5.6.2	Pavement Construction.....	32
5.7	Stormwater Infiltration.....	32
5.8	Earthwork and Excavations.....	34
5.8.1	General Site and Subgrade Preparation.....	34
5.8.2	Difficulty of Excavations.....	35
5.8.3	Wet Season Construction.....	35
5.8.4	Excavation Dewatering.....	36
5.8.5	Excavation Shoring.....	36
5.8.6	Temporary Cut-slopes.....	37
5.9	Structural Fill Recommendations.....	37
5.9.1	Use of Structural Fill.....	37
5.9.2	Installation and Compaction.....	38
5.9.3	Existing Material Suitability.....	38
5.9.4	Imported Material Specifications.....	38
5.10	Utility Construction.....	39
5.10.1	Utility Trenching and Excavation.....	39
5.10.2	Backfill and Pipe Zone Bedding.....	40
5.11	Contractor Responsibilities.....	41
5.12	General Critical Area Guidelines & Recommendations.....	41
5.12.1	Stormwater Management.....	42
5.12.2	Site Management During Construction.....	44
5.12.3	Long-term Erosion Control and Maintenance.....	44
6	Closure.....	46

References.....	47
Appendix I	1
Appendix II	2
Appendix III	3

1 Introduction

1.1 General Overview

Element has completed this geotechnical investigation and geologic hazard assessment on behalf of the clients, property owners, for contribution to the plat design and approval process for proposed residential development of the project site. In general, the work was conducted to provide a distributed subsurface site characterization and inform preliminary geotechnical aspects of project feasibility planning and engineering, including the influence of steep slopes within and bordering the development area. The project entails establishing a new plat with approximately 38 lots and associated road and utility infrastructure in Bellingham, Washington. The project site is located south of Fairhaven, on Viewcrest Road, in the Edgemoor neighborhood. The site is situated within a hilly and forested upland area bounded by a sheltered bedrock bluff slope defining the northern margin of Chuckanut Bay. Refer to Appendix I (Figures 1 and 2) for maps depicting the general site location, surrounding vicinity conditions, and current proposed lot and road layout.

1.2 Project Understanding

The proposed project involves future plat development of the currently vacant and forested hilly site with a single-family residential community. The project is currently in the design stage and subject to changes in layout at the time of this report. Preliminary layout plans (Pacific Surveying & Engineering) indicate that 38 residential parcels are anticipated to be created within the plat. One open space tract and one reserve tract will also be created within areas largely occupied by wetlands or geologic hazards and their associated buffers.

Two main neighborhood roads are planned to service the site, branching from a single entry at Viewcrest Road, at the north-central end of the project area. The roads are shown to extend immediately southward from the main road, then branch southwest and south across the middle of the site following existing topographic benches traversing between areas of steeper or more variable topography. Both roads will terminate in cul-de-sacs within the site. Several shared access driveways are planned to extend from the sides or ends of the main roads to service each lot.

Current road grading plans indicate the roadway corridors will be prepared using a combination of cuts and fills to address local variations in topography. Commonly, the northwest sides of the roads will involve new cut slopes, while the southeast sides will be constructed at grade or over some extent of structural fill.

No information is available on proposed lot grading or foundations, which will be addressed in later lot-specific designs. Based on standards of practice in the area, we presume the future structures will typically use stepped foundations and/or daylight basements where topography is variable or sloping. No excessive fill placement or unrestrained cuts are anticipated for lot preparations. Structural loads are expected to be typical for the scale of single-family residences with wood framing. No unusually heavy, variable, vibratory, or cyclic loads are anticipated.

The majority of stormwater generated from new impervious areas on roads and lots is expected to be collected, treated as necessary, and routed to upland dispersion areas and/or a main tightline outfall leading down to the shoreline. Stormwater from the northwest portion of the project area may be infiltrated as feasible, and otherwise directed to existing utilities along Viewcrest Road.

1.3 Purpose and Summary of Scope

The purpose of our investigation was to conduct a feasibility-level geotechnical evaluation and large-scale geologic hazard assessment in support of the proposed plat application and its public road improvements. The scope of work performed was in general accordance with the executed project agreement, with adjustments made during the course of the project based on actual conditions encountered. An additional scope of work was completed upon request in support of utility design along the western terminus of Sea Pines Road.

In summary, our final scope of site investigation has included:

- 1) Desktop review of existing geologic and soils information for the project area (as based on mapping by others and public information), as well as GIS analysis and imagery review of on-site and proximal off-site sloping topography.
- 2) Site visit for planning of access, utility notification marking/filing, and verification of utility clearances prior to conducting geotechnical explorations.
- 3) Direction and observation during excavation of twenty-six (26) test pits within the plat project area by a subcontractor, using a rubber-tracked mini-excavator, to termination depths of 2.0 to 8.0 feet below existing ground surface (bgs).
- 4) Visual reconnaissance of site interior areas to generally assess the character of slopes, observe for and map geologic hazards, and document/measure exposed bedrock structures.
- 5) Additional explorations off site at Sea Pines Road for utility construction planning. Two (2) test pit excavations and two (2) hand auger borings were performed at the western end of Sea Pines Road, near the eastern boundary of the project site.
- 6) Review and analysis of field data to assess targeted infiltration potential, slope stability, and formulate feasibility-level geotechnical recommendations for plat development.

1.4 Assumptions and Limitations

The composition and characteristics of subsurface soils were assessed by the observing geoscience professional using available geologic information and field interpretations at the time of excavation. It is possible that soil conditions, variations, or transitions occur that are not fully characterized or identified by the field observations and sampling/testing program.

No data is available for exploration depths and locations other than those recorded in the attached exploration logs. The composition and physical properties of the substrate below those depths, or in areas beyond the immediate exploration locations, cannot be determined without additional geotechnical evaluation. Soil composition, groundwater depth, and the physical properties of the substrate can vary considerably depending on geographic location, elevation, and seasonal or climactic factors. Such variability should be expected and anticipated over the study area. The actual character and type of bedrock may also vary among areas between rock exposures.

Groundwater conditions are likely to vary seasonally, and may also differ between locations within the site. The reported groundwater conditions are valid only for the date and location of exploration. If necessary for design, additional targeted explorations or seasonal monitoring of groundwater should be completed.

2 Desktop Review and Interpretation

2.1 Methods

The following desktop analysis was conducted by a qualified earth science professional and, although it is built on previous studies and information obtained by others, it includes new interpretations based on professional judgment and experience. The desktop data inventoried in Table 1 cites the available geospatial data for the subject area, which was evaluated using scientific methods based upon industry best practices.

Table 1: Data Used for Desktop Analysis

Data	Format	Date	Source
Aerial photography (Orthophoto)	SID/JPG	2017/2019	USDA/Whatcom County
LiDAR	Bare earth grid	2017	NPSL
Geology	Shapefile	2006	DNR 1:100,000 Digital Geology
Soils	Shapefile	Current	USDA/NRCS Soil Survey

2.2 Location and Physiography

The large-acreage site is located within the southwestern-most part of the City of Bellingham, on the northwest end of Mud Bay. The main site frontage is along Viewcrest Road in the Edgemoor neighborhood of Fairhaven. The site is on the south side of the road, and extends south and downhill to the bay shoreline. The east margin of the site runs north-south near the cul-de-sac terminus of Sea Pines Road. The west margin runs north-south near the cul-de-sacs off South Clarkwood Drive. Bordering sites to the north, east, and west are predominantly developed and in present use as single family residential properties with similar scales of buildings and exterior improvements as the proposed project development. Refer to Appendix I (Figures 1 and 2) for maps depicting the general site location, project boundaries, and surrounding vicinity conditions.

The property is comprised of several contiguous parcels totaling 37.4 acres. The site interior remains generally well forested, populated with mixed conifers and deciduous trees of varying ages along with mature typical undergrowth (ferns, small brush). The site exhibits variable, hilly upland topography throughout a majority of its land area. The upland topography is similar in character to that of residentially developed areas to the east and west. The area along the Viewcrest Road frontage is very gentle to flat, and cleared in the northeastern region of the site while remaining forested in the northwest area. The southeast portion of the site, well outside of the plat development area, consists of a large shoreline bluff slope, over 40% grade and around 100 feet in height, extending down to the shoreline. Further review of slopes within the proposed project development area is provided below.

2.3 Geologic Background

The early geologic history of the northern Puget Lowlands is defined by tectonostratigraphic terrane accretion. Volcanic island arcs and associated terrestrial and marine sedimentary units collided with and were incorporated into the continental margin during subduction of the oceanic Farallon plate. This process was ongoing through the upper Mesozoic Era and resulted in the highly faulted and deformed exotic terranes associated with the exhumed and uplifted Northwest Cascades System.

By the lower Cenozoic Era, the crustal material comprising basement rock of the Puget Lowland had formed a pull-apart basin submerged beneath a shallow subtropical sea, which received both continental and marine sediment inputs. This depositional period, constrained to roughly 58 to 50 MA (Lapen, 2000), resulted in the thick sandstone, conglomerate, mudstone, siltstone, and bituminous to subbituminous coal of the Chuckanut Formation prevalent in the Bellingham area. Later folding, tilting, and uplift of the sedimentary unit caused the complex bedding patterns that influence and are exposed by today's landscape. Various continental glacial episodes occurred in recent geologic history, capping valleys and low coastal areas with thick glacial sediments, and commonly mantling foothill areas with thin glacial drift or till soils. Among hilly lowland areas such as the project site, it is common to see a range of shallow conditions over bedrock at depth. Shallow soils can include bedrock-derived colluvium, glacial drift/till, glacial outwash, and locally fine alluvial or organic deposits.

Geologic mapping at 1:100,000-scale, conducted by the Washington Department of Natural Resources (DNR), indicates that the study area is underlain by the Padden Member of the Chuckanut Formation (E_{cp}). The Padden Member is a sedimentary bedrock unit described as "moderately to well-sorted sandstone and conglomerate alternating with mudstone and minor coal. Sandstone ranges from fine to coarse grained, with pebbly to conglomeratic sandstone layers common" (Lapen, 2000). In our experience, it is common for bedrock to be overlain by about 2 to 5 feet of cover soils such as colluvium or mantling glacial deposits, varying locally.

2.3.1 NRCS Web Soil Survey

The United States Department of Agriculture (USDA) Natural Resources Conservation Service (NRCS) Web Soil Survey for Whatcom County indicates that there are two primary soil units in the study area; *Everett-Urban Land Complex, 5 - 20 percent slopes* (NRCS Map Unit 52) extending into some northern areas of the site, and *Nati loam, 30 - 60 percent slopes* (NRCS Map Unit 110) across the central and southern majority of the site interior.

Everett-Urban Land Complex, 5 - 20 percent slopes (NRCS Map Unit 52)

This unit typically forms on moraines and terraces from a parent material of loess and volcanic ash over glacial outwash. Typical soil profile consists of gravelly ashy sandy loam through 25 inches depth, then very gravelly sandy loam, loamy sand, and sand through 60 inches depth. The Everett soil is somewhat excessively drained, but has a very low to low capacity to transmit water through its most limiting layer. The unit is assigned Hydrologic Soil Group B and not noted as being prone to flooding or ponding. Depth to seasonal groundwater is typically between 39 to 59 inches. Restrictive flow conditions (densic material) is encountered in the range of 40 to 60 inches depth.

Nati loam, 30 - 60 percent slopes (NRCS Map Unit 110)

This unit typically forms on hillslopes from a parent material of volcanic ash, colluvium, and slope alluvium derived from sandstone, siltstone, and glacial drift. Typical soil profile consists of ashy loam through 38 inches depth followed by weathered bedrock to 42 inches depth. The Nati soil is well drained and has a moderate to high capacity to transmit water. The unit is assigned Hydrologic Soil Group C and is not noted as being prone to flooding or ponding. Depth to seasonal groundwater is typically greater than 80 inches. Paralithic bedrock is typically found beginning in the range of 20 to 40 inches depth.

The findings of our explorations are broadly consistent with the geologic and soil survey mapped units. The shallow soil column consists generally of glacial drift or colluvium and is capped with thin cover deposits derived from or composed of weathered native materials. Drift and colluvium deposits are underlain by bedrock consistent in composition and character with the regional Chuckanut Formation. Exposures on steep rock outcrops are also consistent with the folded sedimentary layering of the Chuckanut Formation.

2.4 Geologic Hazard Commentary

Due to the prevalent and variable sloping grades within the project site, and its bordering slope conditions, we performed an initial image review of topography and slope characteristics to determine the approach and focus for reconnaissance-level field review. In the course of this study, we assessed the presence of any obvious active geohazard features, as well as to determine if on-site or proximal areas fall under standard critical area designations for steep slopes as defined by gradient. City of Bellingham Municipal Code (BMC) 16.55.420(B) defines *Landslide Hazard Areas* (LHAs) as slopes having a consistent grade of 40% or greater and a height change of at least 10 feet. *Erosion Hazard Areas* (EHAs) are defined as areas of topography exceeding 30% which are underlain by erosion-prone soil types. BMC language does not differentiate between areas of steep grade and areas indicating active or historical instability; however, this is an important designation for assessing stability and risk of future hazards. For the purposes of our review, we refer to *potential* LHAs as areas of steep grade (over 40% and 10+ feet height), versus *active* or *historical* LHAs defined by interpretation of presence where applicable.

2.4.1 Slope Gradient Review

City of Bellingham CityIQ GIS data (accessed on-line) was initially reviewed for topographic information relating to slope grades. Within the subject site, slope grades are shown by this resource to vary typically under or over 15%, with some prominent hills and scattered features over 40% sustained grade. Steep slopes of the site development area are shown as under 100% grade (1:1), with exception of a steep rock exposure in the northwest quadrant. The regularity of slope occurrence prompted our further detailed spatial analysis using LiDAR-based topography.

The results of our detailed GIS-based topographic analysis are shown in Figures 3a and 3b. This detailed approach demonstrates that a majority of the site interior has grades of under 15% or between 15% and 30% (not regulated by critical area code), shown in light green and yellow shading, respectively. Small scattered areas within otherwise gentle topography are shown as exceeding 30% grade; however, the isolated occurrences are likely to reflect small surface variations on the scale of a few feet that are not indicative or relevant to development regulation. We conclude that the site generally does not contain EHAs that are not associated with and more appropriately classified as LHA areas (either *potential* or *identified*).

Areas over 40% grade are shown on Figures 3a and 3b as orange, and grades over 80% in red. ***The site contains various slope features within the development area that are correctly classified as potential LHAs.*** The steepest grades within the project area occur on the southeast faces of hillsides, and generally correspond to areas of bedrock exposure. Some isolated and small but steep features appear to be related to historical primitive road cuts. In Section 4, we present the findings of visual field review of steep slopes and steep rock exposures; and we provide interpretations of site stability based on a combination of reconnaissance findings and field data.

2.4.2 Special Hazard Areas

Two features of special significance were evident in initial image review. These include: 1) the main southeast shoreline bluff slope, and 2) an area of bowl-shaped topography at the northeast corner of the property. Figure 4 presents site-wide LiDAR imagery including delineation and annotation of the areas noted below.

- 1) The southeastern bluff slope is consistently steep, commonly over 80% grade, and in some areas exceeding 100% grade (1H:1V). The crest of the southeast slope is at roughly 80 feet to 120 feet in elevation (above sea level) depending on area. The crest typically exhibits an over-steepened top of the slope and shows signs of past localized mass wasting activity (serrated trend with cusped features). The main body of the slope face varies between around 40% and over 80% grade with an overall slope of about 1.5H:1V. From aerial and shoreline photography, we can see that the slope and upland area behind the crest remains forested with mature evergreen trees. At the base of the slope and along the face, are visible areas of exposed bedrock that appear to be dipping moderately or steeply northward into the hillside. We interpret the slope to be comprised of intermittent outcrops of steep resistant bedrock planes, interspersed with colluvium slopes that are reclined enough to support the existing forest vegetation. Despite the locally hazardous features present, we infer that the slope has a high degree of internal global stability as a function of the bedrock-structure orientation. The plat development proposes an “open space” tract along the entirety of this feature. Furthermore, the lots proposed uphill from its crest are sufficiently large to permit a substantial setback (well in excess of 100 feet) from the bluff slope. In our opinion, a detailed review of the feature is not necessary for plat approval.

- 2) The northeast corner of the project area, to the west and northwest of the Sea Pines Road terminus, exhibits geomorphic features indicative of a historical landslide feature (Figures 4 & 5). However, the actual history of the feature is not known. Signs of potential historical mass wasting activity include a concave and convergent topography, arcuate slope crest, and steeper upper scarp with lower-angle interior slope. The presence of wetlands within the interior basin is also consistent with this interpretation. With exception of its northernmost areas downhill from other off-site residences (lots not in project area), the crest is somewhat diffuse below and adjacent to the project development area, indicating some time since formation of the landform. We infer that this is likely a historical mass wasting feature with local crest reactivation or episodic retreat occurrences at its north end. The likely cause(s) of the feature at its location are not clear. It is plausible that the area originally held thicker soil deposits than elsewhere, and may have been influenced by concentrated runoff, or subsurface groundwater concentration (given the wetland presence). It is also possible that the feature originally dates back to the time of late-stage glacial recession, when surface conditions were more volatile. We have delineated the approximate boundaries of the feature (Figures 4 & 5), and the preliminary plat layout has been adjusted for avoidance of its extent plus standard 50-foot landslide hazard buffer. Based on the avoidance, no further review is necessary.

3 Geotechnical Explorations

3.1 Methods

Site surface characteristics within the project area were evaluated in the field during reconnaissance by the geotechnical team prior to and at the time of the field explorations. A total of twenty-six (26) test pits were completed, on June 30 and July 1, 2020, to directly observe and evaluate the subsurface conditions throughout the interior of the project site. Test pits were excavated by a subcontractor, using a Yanmar EX35-5 mini excavator, to termination depths ranging from 2.0 feet to 8.0 feet below the existing ground surface (bgs). Exploration locations were selected based on access and to provide optimal representative coverage of the site as conditions allowed. Test pit locations are indicated on Figure 6, Appendix II. Detailed exploration logs and laboratory testing reports are also attached in Appendix II. Select photos of representative conditions observed in test pit excavations are shown in Exhibit A.

3.1.1 Subsurface Investigation

Twenty-six (26) test pits were excavated at representative areas within the project site as access allowed at the time of the work. General exploration areas were pre-selected by Element geotechnical staff based on the provided preliminary development plan, and field-located by an Element Solutions geologist during initial site reconnaissance. Final test pit locations were adjusted based on existing access and utility considerations. Each test pit and boring location was marked in the field using a hand-held TOPCON FC-5000 GPS unit (± 3 m accuracy).

Soils observed during explorations were classified by visual means according to the ASTM D2488 Soil Engineering Classification System. Subsurface water and high moisture conditions, including apparent groundwater level, seepage occurrences, and saturated soils, were also noted as encountered during explorations.

An Element geologist collected representative direct grab samples of soils encountered in test pit excavations. Samples were placed in sealed plastic bags for transport and storage. Following field activities, samples were re-examined to confirm field classifications. Representative soil samples were then submitted for laboratory testing to aid in final classification and for use in analysis of soil design properties. Remaining samples will be stored temporarily by Element; additional testing of samples can be conducted at request of the client.

3.2 Subsurface Soil Conditions

Subsurface soil and bedrock conditions encountered in the explorations were broadly consistent with regional geologic and soil mapping. The explorations support the overall geologic interpretation of the site as underlain by shallow bedrock and associated cover deposits; capped or mantled by glacial outwash, glacial drift, and glacial till varying locally. Cover soils thickness and character differed by location, but generally consisted of organic-rich topsoil underlain by silty sand of glacial deposition or rock-derived origins.

A brief summary of the observed soil horizons is presented below. For complete information, refer to the attached exploration logs (Appendix II). The interpreted geologic unit for each horizon, corresponding to the summaries below, is shown in bold with the soil description.

Uncontrolled Fill: Shallow materials, interpreted as non-native uncontrolled fill were found at one location (TP1, northeastern margin area) to approximately 3.5 feet bgs. The location coincides with an area of somewhat raised grade at the northern extent of the “East Road”, currently a primitive and overgrown off-road feature. Based on topographic indications, we suspect that similar fills may extend into the properties located to the east and west of TP1. The fill consisted of silt with sand (USCS Classification: ML) containing approximately 50% to 60% fines, was soft to medium stiff with depth, cohesive with low plasticity, and damp in the early summer season. The fill contained some chunks of asphalt, and was capped with about 0.7 feet of topsoil. A band of dark orange oxidation staining was observed from about 3.0 to 3.5 feet bgs near the base of the fill material.

Topsoil: Organic-rich silty topsoil (USCS Classification: OL) was present at the surface of all exploration locations to depths ranging from approximately 0.3 feet to 3.0 feet. With the exception of TP3, topsoil horizons found in test pits along the primitive northeast-southwest (NE-SW) trending access corridor (TP2 to TP12 run) were all less than 0.9 feet thick and had an average thickness of about 0.5 feet. The limited depth may be due to prior partial stripping. The northwest margin of the site exhibited a more well-developed and thicker topsoil horizon, often in the range of 1.5 feet to 3 feet. The organic silt displayed consistent characteristics throughout the study area, and contained occasional cobbles and root material. The topsoil was generally dark brown to medium reddish-orange brown, soft, and damp to moist.

Glacial Deposits:

Glacial Drift

Interpreted glacial drift deposits encountered on site were composed of predominately coarse-grained material containing varying degrees of fines, gravel, cobbles, and occasional boulders. Glacial drift soils along the primitive NE-SW access corridor were predominately comprised of silty sand with some gravel and cobbles (USCS Classification: SM) and fine fractions in the range of 20% to 40%. The SM soil was commonly gray to grayish brown, non-plastic, low to moderately cohesive, and typically medium dense at shallow levels before transitioning to dense glacial till or bedrock conditions below. Gravel clasts were sub-rounded to rounded, as were the occasional boulders observed within the unit. Soil water content was generally noted as damp to moist conditions and decreased with depth. Mottling and oxidation staining was often observed in the drift soils, decreasing or vanishing with depth into basal till or unweathered bedrock.

Glacial Outwash

A soil horizon ranging between 1.2 feet and 3.0 feet thick, interpreted as glacial outwash (recessional), was uncovered below the topsoil in the northwest area of the site (TP13 - TP17). The outwash soils were composed of a variety of well- to poorly-graded sand and gravel, with some cobbles, and fine silt content ranging from about 2% to 20%. The granular soils were medium dense, non-cohesive, non-plastic, and damp to moist. Coloring was grayish brown to light gray in test pits where sand was the dominant constituent; and brown to orange brown in areas dominated by gravel. Clasts were rounded to well-rounded, and some caving was observed in test pit walls. Other than TP15, where refusal was met on a large boulder, dense glacial till was found at the base of outwash soils. Outwash-type soils were observed to overlie Drift soils at multiple test pits, and elsewhere was found in substitution for Drift deposits.

Glacial Till

A medium dense to densely compacted mantle of glacial till was found overlying bedrock at a majority of test pits (excluding locations on or near the tops of outcrops). The till unit was composed of grayish brown to light gray silty sand containing some clay, gravel, and occasional cobbles (USCS Classification: SM). Fines content was generally in the range of 20% - 40%, sand content was medium to fine-grained, and gravel clasts were often small and rounded. The SM soil displayed low to moderate cohesion and low plasticity. The density of the till increased greatly in the last 0.5 feet to 1.0 feet of the unit, becoming cemented and blocky, often forming a thin veneer over the underlying bedrock. The upper horizon of the till was locally-weathered and weakened, but became progressively dense with depth. Moisture content was generally low and decreased with depth in concert with an increase in densic or cemented and blocky texture.

Colluvium: Soils distinct from glacial deposits and interpreted as derived from on-site bedrock, either redeposited (colluvium) or weathered in place (regolith / paralithic rock), were observed in areas throughout the site; most often in test pits located on slopes or in high elevation areas. The rock-derived soils were generally comprised of tan to yellowish brown silty sand with some gravel and cobbles (USCS Classification: SM) containing approximately 20% to 30% fines content. Sand was poorly graded and mostly fine to medium. Gravel and cobble clasts were tan and angular. The SM soil was damp, non-plastic, displayed low cohesion, and was medium dense to dense as it transitioned into the more intact weathering rind of the underlying bedrock. At multiple locations in the north-central area of the site (TP-18 & 19), this deposit was found underlying Glacial Drift. Due to the nature of colluvium deposits, they may range in age and character by location.

Soils that appeared to have been weathered-in-place (eluvium) were observed at the top of the outcrop in the northwest region of the site (TP25 and TP26). These soils appeared similar in character to the more frequently observed colluvium, but were made up almost entirely of poorly-graded medium sand (USCS Classification: SP), containing less than 5% fines. The SP soil was yellowish brown, non-plastic, non-cohesive, damp to moist, and loose to medium dense in the upper 3.5 feet before transitioning to the underlying weathering rind and bedrock at 4.0 feet bgs.

Bedrock: Apparent intact sandstone bedrock of the Chuckanut formation was encountered in a majority of test pits across the study area. In the southeast part of the project area, along the primitive NE-SW access corridor (TP2 - TP12), the depth to bedrock was consistently less than 4.5 feet, with exception of TP8 where bedrock was encountered at 8.0 feet bgs. The depth to bedrock was only slightly greater along the proposed "West Road" corridor and in the central region of the site, where refusal was generally met at around 5.0 feet bgs or less. Extracted rock samples were comprised of angular, dry, tan, poorly-graded sand to silty sand. The inferred bedrock conditions are consistent with the Padden Member of the Chuckanut Formation, mapped in and around the study area and exposed in scattered outcrops. See Figure 7 for a summary of depth to bedrock by exploration location.

Bedrock was not encountered in the northwestern corner of the site at the TP13 - TP15 locations, which were terminated in dense till-like conditions or on a large boulder. This suggests that depth to bedrock is greater in the northwest corner of the site. It is also common for the Chuckanut Formation rock profile to vary locally. The depth to rock encountered along the primitive access corridor and proposed "West Road" alignment was relatively consistent and may be broadly representative of the site. However, as observed at TP8, local variation should be expected.

3.2.1 Laboratory Testing Results

Grab samples were collected from test pit excavations at the depths noted on the logs. Following field work, we reviewed the exploration findings and selected representative samples for laboratory analysis to confirm soil properties and visual classifications. Samples were delivered to GeoTest Services, Inc. for hydrometer analysis (ASTM D422/D1140 method), sieve analysis (ASTM C136/C117 method), percent passing #200 (fines content), and Atterberg Limits (Plasticity Index) testing. Organic content (ASTM D2974 method) and cation exchange capacity (EPA 9081 method) testing were performed by Northwest Agricultural Consultants. The sample array and test results are indicated in Table 2 below. Complete laboratory test reports are attached in Appendix II.

Table 2: Summary of Laboratory Testing Results¹

Sample ID	% Gravel		% Sand			% Fines		Atterberg Limits			USCS
	Coarse	Fine	Coarse	Medium	Fine	Silt	Clay	LL	PL	PI	
TP1 - 6'	8	15	5	11	30	20	11				SM
TP2 - 2'	0	8	4	23	54	11					SP-SM
TP8 - 4'						20		51	25	26	SC
TP9 - 4'						22					SM
TP10 - 3'	0	5	2	17	55	21					SM
TP12 - 3'						28					SC/SM
TP13 - 4'	28	28	12	27	3	2					GP
TP13 - 6'	0	20	8	21	23	21	7				SM
TP16 - 3'	26	26	9	22	12	5					GP-GM
TP16 - 4.5'						39		21	16	5	SC-SM
TP24 - 4'	19	21	10	21	21	6	2				SP-SM
TP25 - 2.5'						2					SP

1. Test results from Northwest Agricultural Consultants:
 - a. TP1 (6.0'): Organic Matter = 1.77%; Cation Exchange Capacity = 11.6 meq/100g
 - b. TP13 (4.0'): Organic Matter = 1.50%; Cation Exchange Capacity = 3.9 meq/100g
 - c. TP24 (4.0'): Organic Matter = 1.44%; Cation Exchange Capacity = 6.2 meq/100g

Gradation results from all samples indicate that fines content of the glacial deposits ranges from as low as 2% to as high as around 40%, with typical values between 20% to 30% fines in the drift and till soils and below 10% to 20% for the local outwash deposits. Field assessment of soil plasticity suggested non-plastic to low plasticity behavior in a majority of observed soil types. Atterberg Limits testing of two fine soil samples recorded plasticity index (PI) values ranging from the region of low plasticity silty clay (CL-ML) up to the lower limit of high plasticity clay. Given the depositional source and our field observations of soil character, some variation of fine and coarse fractions and range of plasticity (from non-plastic to low plasticity) is expected, with most soils behaving as non-plastic or low plasticity.

3.3 Groundwater Conditions

Weather conditions were mostly dry during field work with only minor precipitation occurring during the first day of explorations. No excessive surface ponding was observed during field reconnaissance or explorations, outside of designated wetland areas (not assessed in this study). Groundwater and free water conditions were observed directly in excavations. Soils were generally damp to moist throughout the study area. Wet soils were only seen in TP2, where seepage and caving were observed at a depth of 3 feet bgs. However, heavy oxidation staining indicated groundwater levels rise to around 2 feet bgs in this isolated area during the wet season, but was not seen to that degree elsewhere. Varying levels of redoximorphic mottling was observed in soils throughout much of the study area, at depths between 2 feet and 4 feet, also indicate a history of cyclic wetting and drying associated with seasonal groundwater fluctuations, or transient water flow through the upper subsurface. The sloping site profile likely precludes significant perched water table development within the study area. However, some localized areas may be subject to perched water build-up due to depressed or confined areas of topography and the prevalence of restrictive glacial soils or rock at depth. The site is not proximal to any major natural surface water features.

Conditions observed in test pit explorations are interpreted to be representative of the dry season given the timeframe of explorations in the mid-summer. During the wet season, it is anticipated that groundwater and seepage levels will become elevated from those observed in the summer, and that soil moisture contents will be elevated by prolonged wet weather. The groundwater and soil moisture conditions recorded on our test pit logs are valid only for the dates of exploration.

3.4 Additional Explorations – Sea Pines Road

An additional scope of exploration was requested to document and define subsurface conditions in the area of a proposed sewer improvement near the east margin of the site. The proposed connection for Lot 37 (accessed via Sea Pines Road) plans to extend southwest from the existing 8-inch diameter sewer main current western terminus, through a portion of the easement along the north side of Sea Pines Road, and passing beneath the paved cul-de-sac to connect with the outfall from the project site. The depth to bedrock in the utility improvement area may present a challenge or further expense, and influence the final design alignment and depth.

In-progress plans show the proposed extension alignment will run northeast-southwest approximately 40 feet northwest of the Sea Pines Road centerline. Pipe invert elevation is around 105.5 feet at the existing pipe tie-in (NE end), rising gradually to about 107 feet at the connection to the site outfall (SW end). Where the proposed sewer line crosses underneath the existing cul-de-sac, a minimum of 18 inches of cover will be maintained as required. One or more additional manhole structures may be installed in conjunction with this extension. Base elevations of manhole structures would be in the realm of elevations 105 to 106 feet.

3.4.1 Methods

Subsurface explorations were performed in the vicinity of 315 Sea Pines Road on November 13, 2020. Weather at the time was intermittently rainy. Two (2) test pits (TPs) were machine-excavated in the grassy area north of the cul-de-sac. Two (2) supplemental hand auger borings (HAs) were completed in the area just west of the cul-de-sac during the field visit. An aerial photo site map showing the Sea Pines TP & HA locations (Figure 8) and surveyed topography, subsurface TP and HA logs, and a field photo array (Exhibit B) are attached in Appendix II.

3.4.2 Subsurface Conditions

Test pits were excavated to depths of 6.8 feet bgs (TP-1) and 6.6 feet bgs (TP-2). Organic topsoil and silty/clayey sand were found to overly bedrock at TP-1, and dense glacial till at TP-2. The thickness of cover soils was around 5 feet in each location. The upper soil was generally medium dense and damp to moist or locally wet, containing 20% to 50% fines and exhibiting variable levels of plasticity as interpreted in the field.

Bedrock conditions in TP-1 were observed in the southern (downslope) wall of the pit at a depth of 5.5 feet bgs, and were also present at the central base of the pit. Bedrock was composed of dense, dark gray, medium to fine-grained intact sandstone. Although bedrock conditions were not directly observed in TP-2, it is likely that the dense till material is a thin mantle that is underlain by rock, as seen in numerous other test pits performed within the study area to the west. Shallow seepage was observed between 2.5 feet and 3.5 feet bgs in TP-1, and between 1.2 feet and 2.5 feet in TP2. Seepage appeared to be constrained to the upper soils in the test pits, with moisture content decreasing at depth. Explorations were done in the late fall shoulder season; seepage levels are, therefore, likely elevated from dry season conditions, but not necessarily representative of fully developed wet season conditions.

One hand auger boring (HA-1) was advanced horizontally into the slope cut located just west of the driveway for 315 Sea Pines Road. The boring was advanced through silty sand that transitioned into sandstone weathering rind before hitting refusal at 1.0 feet bgs on very dense, apparently intact, bedrock conditions. Bedrock composition in this location was consistent with conditions observed in other regions of the study area, composed of orange-brown to tan, medium- to fine-grained sandstone.

HA-2 was performed just southwest of the cul-de-sac, south of the proposed sewer alignment in a vegetated area. The boring revealed approximately 0.6 feet of topsoil overlying silty sand containing some clay and gravel with the occasional cobbles, similar to cover soils seen elsewhere. The boring was advanced to an end depth of 4.2 feet bgs where refusal was met, apparently due to a large cobble in the subsurface. Although no groundwater was observed in the boring, and no heavy bands of oxidation coloring were observed, light mottling throughout indicates that the soil likely transmits some amount of water at least intermittently during the wet season.

3.4.3 Utility Construction and Bedrock Profile

Following field work, test locations were accurately plotted on a survey map to estimate surface and bedrock elevations. Shallow bedrock was discovered at the toe of the slope in HA-1, around elevation 117 feet, near where the utility will exit eastward from Lot 37. Dense rock conditions were found to be present approximately 1.0 feet into the slope at this area. Whereas, HA-2 found no bedrock through 4 feet depth (roughly elevation 106 feet), suggesting depth to rock can be highly variable along this area at the base of the slope. This could present challenges for excavation to planned utility bedding depth if rock is present at final design location and depth.

At the northeast side of the cul-de-sac, termination of TP-1 was around 5.0 to 7.0 feet bgs on bedrock (elevation 108 feet to 110 feet). At TP-2, bedrock was not present through 110 feet elevation. With an invert elevation in the realm of 106 feet, construction of the sewer outfall line and related structures may contact and require removal of bedrock on the order of a few feet thickness, or less.

4 Geologic Hazards & Slope Stability

4.1 Review Methodology

The presence and condition of delineated potential Landslide Hazard Areas (LHAs) within the project development area was reviewed as part of this feasibility-level study. As noted in Section 2.4, portions of land within the project site and bordering areas exhibit topography with the combination of height and grade to be defined as *potential* LHAs. The occurrence of defined LHAs is common for hilly areas dominated by bedrock geology in our region, but does not necessarily portend a high or imminent risk of failure. Nor does it trigger blanket avoidance requirements that prohibit construction. Rather, these features are examined on a case-by-case basis to assess the actual hazard presence or potential thereof, and to formulate recommendations for informed development to minimize the risks associated with these natural conditions.

Detailed lot-specific review and exploration for final design recommendations for structures is outside the scope of this study. It is our understanding that lot-specific investigation of subsurface conditions for final design and building permit review will typically be completed individually by the owner at the time of lot development (as is precedent). A lot-by-lot review of existing geohazard features can be completed as needed for the plat approval process under an additional scope of work, if required. A discussion of further work anticipated is included in Section 4.4.

Element Solutions has performed a large-scale feasibility-level assessment of on-site geologic hazards which has included the following components to date:

- Image interpretation and identification of areas of interest for field review (4.1.1)
- Consideration of potential failure mechanisms and contributing geologic conditions (4.1.1)
- Reconnaissance of vegetated/forested slopes to assess for signs of instability (4.2)
- Detailed observation and structural measurement at several steep bedrock outcrops (4.3)
- Graphical analysis of bedrock structures and outcrop stability factors (4.3)
- Determination of actual hazards and recommendations for setback/avoidance (4.4)

4.1.1 Stability Factors and Areas of Potential Hazard

The findings of subsurface explorations and our observation of local exposures indicate that the site is capped by various shallow soil deposits and underlain by folded and tilted sedimentary bedrock of the Chuckanut Formation. We infer that large-scale deep-seated, or global, stability at the site vicinity is controlled and influenced by bedrock structures. Thus, the orientation of rock structures in reference to topography is the primary factor for slope failure modes. Conversely, the stability of shallow soils at a given location is a function of several factors including the character of local deposits, presence of groundwater and potential for runoff inundation, steepness of grade, and stabilizing vegetative cover. As the underlying rock profile limits the depth of a potential failure, the most likely types of failures in cover soils include shallow slumps, translational slides, and saturated mudflows. The most common trigger for shallow instability is oversaturation by groundwater or runoff. Larger circular failures in the site vicinity may be possible where capping glacial soils are thick, or where the underlying bedrock is sufficiently weak/fractured to behave like a soil mass (not observed). Neither condition was found in test pits, although the noted apparent historical landslide area at the northeast corner of the site may have been influenced by a combination of these factors.

Upon reviewing slope gradient and LiDAR maps, we identified several features for particular focus during reconnaissance. The features occur *within and bordering the proposed development area*, are indicated on the annotated site map (Figure 9, Appendix III), and include:

- Northwest-facing forested slope in the NW quadrant of the site
- Various localized western and central vegetated slopes
- Northwest and west-central steep southeast bedrock faces
- Southeast-facing forested slope within the SW portion of the site

As discussed in Section 2.4.2, we also considered the presence of two specific hazard areas at the margins of the development area (Figures 4 and 5). These features represent known or suspected geologic hazards that may influence the site's final development approach. The coastal southeast slope downhill of the project area is a steep and prominent topographic feature that commonly exceeds 100 feet in height. An apparent historical landslide area is present at the northeast corner of the project area. Reconnaissance and direct observation of these bordering areas was limited or not possible within the scope of this study due to safe access difficulties. Given their location relative to proposed development features, the current review relies upon inferences from site geology and LiDAR image interpretation to set conservative setback standards.

4.2 Slope Review & Observations

During our subsurface exploration program, and following visits for examination of identified areas of interest, an Element Project Geologist and Licensed Engineering Geologist observed conditions of the vegetated slopes among the project area. The purpose of our assessment was to evaluate the present-day stability of the site slopes, and to assess for the presence of indications or features associated with past instability. We traversed the slopes of interest on foot, noting topographic and vegetation patterns and searching for the presence of failure features such as scarps, eroding gulleys, hummocky accumulation zones, etc. Element staff also photo-documented representative slope and bedrock outcrop conditions (Exhibit C). The following subsections address conditions observed by referenced area.

4.2.1 Northwest Slope

This slope is generally planar on the northwest side facing Viewcrest/Fieldston Roads. Elevation increases continuously to the southeast from about 230 feet at the base to about 350 feet maximum at the crest of the slope over a distance of about 250 feet for an average slope ratio of approximately 2:1 (H:V). Statistical analysis of the entire backslope area indicates a mean slope grade of around 50% (~27 degrees). In our experience, this grade is typical for forested, bedrock-controlled slopes in the region.

A predominant majority of the slope area is covered by an established tree canopy, and is vegetated with ferns and other native shrubs. Although many of the trees on the slope were growing straight, some displayed pistol-butt profiles, leaning trunks, and exposed root, indicating that some degree of long-term shallow soil creep is occurring (as is common for steep slopes). The lack of adequate rooting depth may also be contributing to tree orientations, independent of the soil creep phenomenon. Many trees were seen along the edge of the rock cliff face, indicating a stability in the underlying earth material on the plateau of the hill. While some small alders were observed to have fallen from this area, it is likely due to windthrow and a shallow root system, rather than general instability (Photo 1, below).

Based on vegetation patterns, GIS data analysis, and field observations, the northwest slope appears to be in an overall stable condition lacking signs of large-scale or local instability (aside from typical soil creep). The ground surface is well vegetated, and free of signs of heavy localized erosion or channeling of runoff. Where the ground surface was visible, we did not see indications of slope face retreat, serration or tension cracking, or subsidence that would indicate episodic movement. Some local evidence of historical rock-fall debris was observed near the base of the northwest slope face, but the incidence of fall did not appear to be high, and fallen materials did not extend far from the slope. No ponding, saturation, or seepage was observed above or on the slope during our visits in the summer 2020 season.

The opposite southeast side of the northwestern hill exhibits a steep or cliff-like face with prominent bedrock outcrops. Similar conditions are present to a lesser magnitude along the southeast faces of multiple smaller hills in the central project area. The cliff-formed faces are typically continuous for around 10 to 20 feet maximum and interspersed or bordered with vegetated steep slopes. Small scale rock-fall was observed along the southeastern side of two of the prominent ridge features in the central region of this area, interpreted to be occurring at a low rate of regularity. Detached bedrock blocks were not observed to have traveled far from their points of origin on the outcrops.



Photo 1: Bedrock Cliff Face; Northwest Slope

The cliff area along the northwest hill represents the greatest exposure and highest hazard potential for associated rock-fall (Photo 1, above). At its steepest point, the elevation drops about 37 feet over a horizontal distance of ~25 feet for an average slope ratio approaching 1:1.5 (H:V) along the cliff face. Grades range up to approximately vertical, and are locally overhanging on the variable outcrop faces. We observed these features to be highly influenced by the regularity and orientation of rock structures dictating their stability and character. Section 4.3 below provides a review of bedrock features and structures.

4.2.2 Western and Central Slopes

Select slopes among the middle western and central regions of the site display topography meeting the definition of a critical area slope. These slopes are similar in character to the dominant northwest slope, but occur on a smaller scale interspersed within areas of relatively gentle grades (15% to 30%, or under 15%). Topography appears to be bedrock-controlled, with steeper faces, locally cliff-formed, outcropping on the south or southeastern side of the raised areas. The steeper faces, where grades are greater than 80%, are only continuous for around 10 to 20 feet maximum. Small-scale rock-fall evidence was observed along southeastern side of two of the prominent ridge features in the central area. Similar to the northwestern area, detached blocks and rocks were not observed to have traveled far from their points of origin.

The landforms of interest consist of local rises on the order of about 20 feet maximum expression in relation to surrounding topography that is more gently rolling or sloping. With exception of the

noted cliff faces, slope gradients are in the range of about 2:1 (H:V) up to 1.5:1 locally. At the top of each local slope area, is plateau or bench topography of low grade. Vegetation is well-developed forest with mature trees and typical undergrowth. During representative reconnaissance of the vicinity, we saw no obvious indications of instability or excess erosion occurring on the steeper grade areas. There were no features identified that would constitute an active geologic hazard.

4.2.3 Southwest Slopes

Slopes flanking the southern project area can be divided into two areas with distinct character. The upland southwest slope begins within the proposed plat lot area and descends with some local breaks, at a predominantly moderate grade, down to a large gentle bench of variable width. The lower coastal southeast slope below the bench descends steeply from crest to shoreline.

The lower coastal slope was identified as a special geologic hazard area recommended for avoidance, with character overviewed in Section 2.4.2. The plat development proposes an “open space” tract along the entirety of the crest of this feature. The proposed lot layout also provides room for substantial setbacks of residences from the lower slope crest (roughly 200+ feet at all lots). We conclude that the proposed layout meets the preferred “avoidance” of the hazard area as well as a reasonable buffer zone. No detailed reconnaissance-level assessment was conducted.

The upland southwest slope generally consists of a series of smaller banks and narrow benches along its upper third (near proposed building areas), followed by more continuous sloping grades downhill. Intermittent slopes on the upper part are roughly 10 to 20 feet high and around 2:1 (H:V), up to 1.5:1 or steeper locally. Benches are on the order of 10 to 20 feet wide with grades under 30%, or below 3:1. The slope and bench topography appear to be controlled or influenced by underlying large bedrock structures, which outcrop locally. Below the second bench (downhill of all proposed building areas), the slope falls at grades of around 2:1 for approximately 50 to 60 feet of elevation until transitioning into the large lower bench of the site (outside of project area).

Topographic contours and LiDAR imagery illustrate that the southwest slope is a generally planar feature; aside from the bedrock-influenced benches breaking the upper third into multiple smaller banks. There are no obvious geomorphic features on the slope suggesting a history of slope failure or channelization of the slope face. There are no apparent head scarps or bowl-shaped features. During reconnaissance, we did not observe any indications of historical or active instability. The slope is well-vegetated with mature forest growth. Trees are generally straight or have minor curvature/tilting attributed to typical soil creep phenomenon.

Aerial photo imagery of the shoreline area was acquired for calendar years 1977, 1994, 2001, 2006, and 2016 to assess for indications of changes or evolution among the southeast slope and coastal area. All images were retrieved from the Department of Ecology Shoreline Photos collection (accessed online). The photo series illustrates that the shoreline and upslope site conditions have not changed appreciably over the preceding 44-year timeframe. Contemporary site conditions appear relatively unchanged from photos taken in years past, and no major clearing or site alterations were observed in the southeast upland area. No obvious indications of mass wasting, such as land scars or loss of vegetation on the slope or shoreline, were observed within the site or surrounding area throughout the period of photo-record. Based on the photo record, we interpret that the shoreline has not undergone visible retreat and that slopes along and above the coastline have remained generally stable over the last 44 years.

4.3 Bedrock Outcrops & Structures

During reconnaissance, several prominent rock outcrop slopes or cliffs were identified that corresponded to areas of steep to very steep topography indicated by imagery. An Element Project Geologist and Licensed Engineering Geologist returned to the site for detailed observation and direct measurement of the character and structures of the exposed bedrock. We also noted the patterns of rock debris, including extent, size, and relative age, associated with rock cliff areas.

Rock character, intactness, and structural features were examined and documented on the individual outcrop scale (Exhibit C). We measured representative structures with a 360 Azimuth Brunton compass, noting strike and dip of planar features. Rock structures measured included primary bedding, main and secondary jointing patterns, and other planes of weakness if present.

4.3.1 Bedding

Within the project area, **bedding strikes roughly east-west to northeast-southwest, dipping north and northwest at moderate to steep angles**. According to geologic map resources (e.g. Lapen, 2000), the site lies along the north limb of a broad anticline that traverses the ridge of Chuckanut Mountain, in a northwest-southeast trend, before bending west through the north end of Chuckanut Bay. The hinge of the anticline plunges moderately westward, creating an elongated “V” pattern of major bedding structures and oblique bedding orientations that change by location relative to the hinge. At the site location north of the hinge, bedding is dominantly north- and northwest-dipping. This site-scale pattern can be seen on LiDAR imagery (Figure 4) where resistant beds outcrop or directly influence topography. At the east part of the site, bedding is close to an east-west strike, whereas the west part of the site exhibits northeast-southwest striking topographic features interpreted to be representing or influenced by bedding planes.

It is not clear why the bedding orientations and outcropping patterns are irregular within the site, and outside the scope of this work to further assess. Variations in bedding may be attributed to natural variance in folded rock, since the planar orientation does not range more than about 10 to 20 degrees in each direction from a rough-average ENE-WSW strike. It is also possible that more complex secondary folding is present, and/or that the western part of the site is approaching the fold hinge and reflecting the hinge orientation in part. Also unclear is why the prominent rock faces are isolated and discontinuous in the uphill half of the site, while the rock patterns and outcrop style are relatively consistent along the southern margin and coastal area. It is plausible that the upland area was more heavily affected by the advancement of glacial ice over several ice age episodes. While glacial deposits are relatively thin, the effect of rock erosion during glacial advance may have been significant enough to alter the upland landscape.

Generally speaking, the major bedding orientation (dipping northwest, into hillsides) is favorable for site slope stability. We examined this relationship and variations on the outcrop scale. Bedding on the large northwest cliff face ranged in strike from 220 to 255 degrees (360 Azimuth). Dip of bedding at the northwest outcrop was between 40 and 60 degrees (Figure 10a). Bedding on the smaller west-central outcrops was either broadly similar (west location) or progressively east-west striking (east location). Both outcrops exhibited bedding that was relatively steeper than at the northwest cliff; measured dips ranged from 55 to 65 degrees (Figure 10b). Converse to the bedding, outcrop faces were oriented NNE-SSW or NE-SW and moderately steep to steep overall facing to the southeast. **At all locations, bedding is oriented nearly opposite to the exposed face.**

4.3.2 Joint Patterns

In the folded Chuckanut Formation, it is common to observe one or more brittle joint orientations that occur in a discontinuous, but regular interval on the one-foot to several-meter scale. These planes of weakness are also common enough to influence rock slope stability. In our experience, the primary joint plane is often roughly perpendicular to the bedding orientation, occurring as a result of folding and/or compression of the unit during deformation. One or more secondary joint orientations may be oblique or perpendicular to the first joint set and/or bedding. These are often attributed as bedding expansion joints and, therefore, form weaknesses near orthogonal to the bedding itself but are confined within bedding layers. The result of one or multiple joint patterns on slope stability can range from relatively nil to major depending on joint orientations versus each other and the exposure plane.

In the outcrops, the ***main joint pattern was observed to be steeply to moderately dipping west or southwest and striking NNW-SSE or NW-SE. The dominant orientation is normal or oblique to the exposure faces, and is close to orthogonal to average bedding.*** At the northwest cliff face (Stereonet Figure 10a), the main joints were near-vertical and one companion joint was measured (same strike, dipping opposite direction to NE). At the central outcrops, the main joint planes were typically steeply to moderately dipping to the SW (Stereonet Figure 10b). Joint structures are shown as dotted planes with bedding as solid lines in the attached Stereonet diagrams.

Multiple ***secondary joint or fracture orientations were also measured*** at each outcrop area. We note that these features tended to be smaller, discontinuous planes or open-face fractures that are poorly defined, and thus they do not necessarily represent a major discontinuity structure. However, they can have an influence on outcrop-scale processes such as rock fall hazard. Open planes were observed dipping steeply south or SE in a similar or oblique orientation to the outcrop (possibly influencing the outcrop orientation). These were characterized as rock fall breakage surfaces (see discussion below). We also observed a sub-horizontal joint plane along the northwest cliff face that was not observed elsewhere and may be relatively rare or inconsequential.

Finally, we observed for obvious indications of joints intersecting in unfavorable orientations contributing to rock falls or slides. Excluding the subparallel-to-face joints, ***we did not observe wedge or triangular joint patterns in the outcrops*** that could be associated with a non-planar failure system. This is consistent with our graphical interpretation of joint patterns and orientations relating to wedge failure (discussed in 4.3.3).

4.3.3 Rock Face Stability

Strength of a rock mass is controlled and limited by internal structures that are planes of inherent weakness (bedding/foliation) or fractures (joints, veins, faults), rather than rock strength itself. Inherent planes are penetrative, while fractures tend to be discontinuous but regular in occurrence. Orientation of structures with respect to the slope face influences the potential for various styles of rock slope failures. Major failure types include planar sliding (along a continuous bedding or fracture plane), wedge failure (intersection of two planes forms sliding angle with respect to outcrop), and raveling or toppling (intermittent mass wasting parallel to face, style depends on rock type). Each type of failure is discussed below in terms of its interpreted potential at outcrops on site. Interpretations are adopted from Wyllie & Mah (Rock Slope Engineering, 4th Edition, 2005), based on prior work of Hoek and Bray (1981) for rock slope stability. Stereonet plots (Figures 10a & 10b) were used for graphical analysis and interpretation of failure modes.

PLANE FAILURE:

Planar failures can theoretically occur where a sliding surface emerges on a steeper exposed face. The sliding surface must be dipping greater than the rock's friction angle (commonly between 30 to 40 degrees for granular sedimentary rock). The reference text notes that pure planar failures are rare, as they demand several unfavorable boundary conditions to be met in addition to the correct plane orientation. Planar failures are also limited to planes within about 20 degrees strike of the exposure.

Outcrops and slopes at the site are not at risk of planar failure from the bedding or primary joints.

Bedding dips in the opposite direction of the cliff exposure slopes, and the main joint planes are nearly orthogonal to the slope face. Secondary joint and breakage faces are considered small and discontinuous, and not inherently at risk for sliding failure.

The northwest slope face is oriented similarly to bedding. We surmise that the slope form is influenced by rock bedding. However, the condition does not represent a dip-slope hazard. The topographic slope incline is less than the bedding orientations observed, so that bedding submerges into the ground as opposed to emerging from the slope at a lesser angle.

WEDGE FAILURE:

A wedge failure mode can be created along the intersection of two planes of weakness when the intersection line of the planes satisfies criteria for sliding relative to the slope face, even if the planes themselves would not. Again, the intersection must slope greater than the friction angle of the rock discontinuity and daylight on the slope in an orientation close enough to the slope dip.

We examined potential wedge failure modes resulting from joint-to-bedding and joint-to-joint interactions at the site. The ***main intersection of bedding and joints plots in the northwest quadrant of the Stereonets, and plunges moderately to steeply northwest*** (Figures 10a & 10b), thus into the steep outcrops. Other intersections with bedding and shallow joint planes are all at low angles which do not pose a risk of sliding. While this avoids direct wedge failure, we note that the steep intersections could contribute to small-scale rock fall in the opposite direction when paired with other factors including cliff exposure.

TOPPLING/RAVELING:

Failure by toppling or raveling does not require a sliding scenario, but can occur under a variety of circumstances which vary in severity and regularity by rock type. A key factor for this type of failure mechanism is the presence of a steep, sub-vertical, or overhanging slope face, along with steep bedding and/or jointing planes. Shallow secondary planes which disrupt the main planes can further deteriorate the rock mass.

We infer progressive raveling and/or small-scale wasting of the rock face is a common and unavoidable occurrence at the outcrop locations within the site. The major bedding planes have been dissected by steep and shallow jointing on the foot- to meter-scale, resulting in exposed rock susceptible to localized raveling over time despite the favorable bedding orientation. However, the presence of the natural cliff exposures indicates the rock mass at these locations is relatively stable and subject to a slow process of raveling, presumably since the last glacial episode.

4.3.4 Rock Fall Characteristics

Existing rock debris observed on the ground surface in the downslope vicinities of the several exposures is broadly consistent with our interpretation of raveling and small-scale rock breakage as the main mechanism of rock wasting. We have relied on the empirical patterns of prior rock fall observed in the field to inform their occurrence, apparent regularity, and overall magnitude.

Some evidence of incidental toppling was observed near larger rock faces in the northern and central regions of the project area. Fallen blocks were generally observed to be of an elongated shape, and the majority were measured to be from about 1 foot to 3 feet in size along the a-axis. Blocks were observed to be situated around 10 feet to 15 feet maximum from their perceived points of origin. Some larger blocks, around 5 feet to 7 feet along the a-axis, were also observed to have become detached and traveled short distances. The larger blocks were also of an elongated shape, and were only observed to have traveled about 1 to 8 feet from where they had fallen. The non-spherical shape of the blocks is interpreted to reduce the distance of potential translation or runout, along with the presence of thick forest vegetation hindering runout. None of the more recent blocks observed were noted to have fallen more than about 20 feet from the outcrop of origination.

A few relatively medium to large sized boulders were observed in the valley area downhill of the largest outcrop, below the northwest cliff face. These materials were old enough to be partially or mostly buried and covered in moss growth. Their origin cannot be directly confirmed as outcrop rock fall, as they may be an earlier byproduct of historical erosion and/or glacial depositional processes. Even presuming a rock fall origin, the boulders appear to be of significant age indicating a very rare occurrence potential in the time scale of the project.

4.4 Geohazard Review Findings & Recommendations

This study has involved field reconnaissance and graphical analysis to review slope stability factors and evidence of instability considering both cover soil deposits and underlying bedrock. Based on the work completed to date, we have reached the following interpretations and conclusions on project site slope stability (4.4.1). These conclusions form the basis of preliminary recommendations for building setbacks, mitigations, or development limitations with respect to specific site features (4.4.2). We also address the need for further lot-specific reviews for design and permitting of individual SFR developments. This section focuses on setbacks for building features (structures, roads, etc.). For discussion of stormwater management features placement with respect to slopes of concern, see Sections 5.1.3 and 5.12.1.

4.4.1 Conclusions on Slope Stability for Development

In our opinion, the sloping parts of the site within and in proximity to the proposed development areas (excepting localized steep cliff faces) display characteristics indicating stable conditions are broadly present. Excluding the special hazard areas discussed in Section 2.4.2, recommended to be avoided, we did not encounter evidence of active or historical slope failures, nor areas of excessive erosion. Forest vegetation throughout the site is well established. The combination of grades and subsurface conditions is conducive to maintaining long-term stability of the site with a relatively low risk of instability. The presence, character, and orientation of bedrock underlying the site is also found to be favorable for global stability of the site. Thus, the variable and locally moderate to steep topography intermittent throughout the site should not preclude its development, assuming a proper design and construction strategy is employed.

Proposed roads appear to be aligned in a manner that avoids excessive cuts or fills on sloping areas, taking advantage of natural benches or valleys in topography. Standard cut-and-fill practices and roadside bank constructions are anticipated to be feasible, as addressed below. Small retaining structures can be employed as needed where space is constrained. Roads and driveway extensions have preferentially avoided areas of steeper grades, where possible. The roads do not pass in close proximity to the delineated special hazard areas. Major utility services will be predominantly constructed along the road corridors and protected from slope processes.

The anticipated building areas on individual lots will deal with a variety of terrain situations. In our experience, the combination of topographic challenges and subsurface conditions are not uncommon for home site development in the Cascade foothills within and surrounding the Bellingham area. The blanket code definition of portions of the project site as geologically hazardous areas based on slope grades should not prevent appropriate use on the lots involved. It is expected that individual lot home designs will incorporate foundations that are best fit to the topography. Multi-tier footing systems, foundation retaining walls, and daylight basement features are commonly used to construct homes on topography similar that present on the project site. The soil and bedrock conditions are considered broadly well suited for these approaches to be adopted on a per lot basis during future design and construction.

4.4.2 Preliminary Building Setback & Avoidance Recommendations

Based on the feasibility-scale review completed to date, we recommend the following guidelines for plat planning and individual lot building placement with respect to geologic hazard features. Note that some locations are referenced below to the most current proposed plat layout.

- 1) Generally speaking, unless otherwise addressed below, **areas within the development zone exceeding the 30% (erosion hazard) and 40% (potential landslide hazard) thresholds per code do not require avoidance or setback criteria.** Rather, we recommend development of the areas adhere to best management practices for slope-side design and construction typical for this area. For instance, homes should be carefully sited and designed where steep grades are present to ensure long-term stability of slopes and structures. Local adjustments may be necessary to avoid small-scale features not fully evaluated in the scale of the current work.

Foundations on or near slopes will require embedment and suitable placement on stable subgrades to avoid unacceptable risk. Cut-and-fill leveling of building sites on slopes is not recommended. The use of heightened stem walls, stepped or tiered foundations, and retaining wall features is typically preferred to bank modifications and fill pad construction. In addition, site preparations and restoration measures (erosion control, planting practices, stormwater drainage controls, etc.) must adhere to critical area protection measures as overviewed in Section 5.12.

- 2) Local rock cliff features are recommended to be avoided by incorporating an appropriate setback to building foundations. The setback can be defined by distance from the slope crest above the feature, or from the relative foundation placement depth and location with respect to the outcrop exposure if the approximate building location and design style are known. For the current purposes, we preliminarily recommend setbacks based on horizontal distance from a slope crest irrespective of design. **The recommended setbacks should be reviewed and adjusted as necessary during individual lot design.**

We recommend preliminary minimum horizontal building setbacks from the northwest hill southeast cliff face of 30 feet for Lot 8 and 20 feet for Lot 9, the proposed lots located on the narrow ridge. A preliminary 15-foot minimum foundation setback is also recommended for Lot 14, which is located on the uphill side of the west-central steep rock outcrop. The last notable outcrop, generally located at Lot 20, is smallest in stature and may be partially abated by building pad earthwork. Where steep exposed rock remains below the building area, a minimum 10-foot foundation setback from exposure is recommended. These preliminary **setbacks equate to an approximate 1:1 distance versus height of the underlying steep outcrops**. In our opinion, this is a conservative approach that will provide ample building protection from future potential of instability and periodic rock face loss over the long term.

- 3) Due to the potential for incidental rock fall from the several outcrop faces, **we recommend ample avoidance or protective measures be incorporated for areas immediately downslope of cliff exposures**. For the current proposed layout, home sites that may be directly affected by rock fall include Lots 21 and 22. For full avoidance without need for other mitigative measures, a **minimum separation of 15 feet from the underside (toe) of the exposed rock face is recommended at these locations**. If home construction is elected or required to be closer to the rock face, use of a separate catchment structure (such as a landscape wall with some free height) or incorporation of a heightened reinforced foundation wall is advised. We recommend the conditions be reviewed in detail on an individual lot basis, where necessary during lot-specific design, and that final recommendations for rock fall avoidance or mitigation be issued at that time based on the proposed building layout.

Road and driveway areas may also be subjected to rock fall where in close proximity to the outcrop faces. Areas of potential concern include the primary access “West Road” traversing the valley area below the large northwest outcrop, the attached small driveway access to Lots 16/17/19/20, and the cul-de-sac of the “East Road” below the central small outcrop. However, with the interpreted rare regularity and low potential for significant runout of rock-fall debris, extensive mitigations do not appear necessary. We advise considering incorporation of a topographic swale or low catchment wall on the uphill side of the “West Road” and the “East Road” cul-de-sac to safeguard from incidental rock-fall reaching the roadway and intersecting driveways. If the road alignment is adjusted to be farther from the cliff feature, these measures can be avoided. Alternatively, as-needed rock fall cleanup and repair could be done in exchange for up-front mitigations where construction is costly or limited.

- 4) The coastal southeast slope and its upland vicinity is recommended to be fully avoided by development. For general planning purposes, we recommend applying a non-development building buffer equivalent to the slope height. Total height varies locally from about 100 feet minimum to around 150 feet maximum. The current proposed layout allows for over 150 feet separation to building zones at all areas, consistent with this guideline.
- 5) The northeast corner area, interpreted as a possible historical landslide area based on geomorphic features, is recommended to be avoided. Per City of Bellingham code, the standard minimum setback from active or historical LHA features to developments is 50 feet. The current plat layout allows for ample setback to upslope areas. This setback can be investigated further on a per-lot basis during lot design, and may be eligible for reduction upon demonstrating adequate factor-of-safety is achieved at a lesser distance.

4.4.3 Need for Lot-Specific Reviews

The site-wide geohazard review completed to date represents an overview of site features with specific attention paid to potential hazards identified along the boundaries of or intermittently within the large hilly property. It is not intended to serve as a detailed examination of the conditions on individual lots to advise on lot designs. Based on our experience, it is most appropriate to conduct detailed evaluation of topographic and subsurface conditions on individual lots in the future just prior to or during their design and development when proposed features and final layouts can be taken into account.

We recommend that all lots containing or bordering potential LHAs (as code-defined, grades over 40% and relief over 10 feet) be required to conduct lot-specific final critical area reviews at the time of building permitting. At minimum, a reconnaissance-level assessment and review of proposed building plans should be completed. We recommend site evaluations include subsurface exploration to assess foundation conditions and prescribe foundation design/construction recommendations for any building areas on or directly adjacent to slopes over 40% grade. Future studies should be responsible for either confirming the findings and recommendations of this report, including setbacks if applicable, or offering new or revised recommendations based on detailed assessment of a lot.

To some degree, further lot-specific review and critical area documentation can be completed supplementally to this report. Some portions of the site can also be addressed in kind (such as lots at the base of the northwest hill, and lots lining the top of the southern slope). If further detailed lot review is required for plat approval or requested by the client, Element Solutions will be pleased to provide the additional assessment on a per-lot basis.

5 Conclusions and Recommendations

5.1 Project Feasibility Discussion

Based on the findings of our site-wide subsurface investigation, geologic hazard assessment, and the interpretations presented herein, it is our opinion that the proposed plat development is feasible as generally proposed. We recommend following the guidelines and recommendations below for plat design and construction. We anticipate conventional design and construction practices will be suitable for this project, assuming a typical level of risk is acceptable.

This study was conducted as a feasibility-level evaluation for the plat, and is not intended to present detailed information for individual lot constructions. In this section, we provide preliminary commentary and general design guidelines for development. On the per-lot scale, the information may need to be expanded upon or modified to address lot-specific conditions. Detailed work done at a later date by Element Solutions or another qualified geotechnical consultant may supersede the broadly based recommendations of this report.

5.1.1 Foundation Feasibility Commentary

For a shallow foundation to be feasible, adverse levels of settlement must be avoided. This requires that either the ground conditions below the structure are suitable for supporting anticipated loads without inducing excessive settlement, or that site preparations and/or design factors are incorporated to minimize inherent settlement risk to an acceptable degree. Settlement can be a result of shallow factors (organic or soft/loose subgrade, uncontrolled or improperly compacted fill, erosion of support, etc.), deeper factors such as soft-soil consolidation, or a combination of both. Foundation settlement can also be associated with sloping grades and insufficient embedment or bearing support.

Native soils at the project site are generally well-suited for residential building foundations and pavement development. The soils are not excessively moisture-sensitive, nor are they of excessively soft consistency or loose density. Shallow deposits are locally variable, however. Shallow saturation in the winter season (caused by underlying restrictive conditions) can also pose a risk for moisture-sensitive subgrade deterioration from freeze-thaw effects. These factors can be mitigated to a reasonable level by careful site preparation to minimize variability and ensure proper subgrades are established. In addition to the prescribed site preparations below, some localized over-excavation of problematic subgrades may be needed during site preparations and home foundation constructions.

With the exception of surficial topsoils and rare historical grade fills at shallow depths, no unsuitable or highly compressible soils were encountered through maximum depth explored. Additionally, the site subsurface is not susceptible to excessive settlement during a seismic event. There are no concerns for loss of building support associated with deeper conditions given the underlying dense to very dense glacial drift/till and bedrock profile throughout the site.

Based on the findings of field explorations and analysis of the site conditions, it is our opinion that shallow footing foundation systems are feasible for the proposed project. In Section 5.3, we provide preliminary foundation design and construction recommendations tailored to the subsurface conditions documented in the site-wide test pit survey.

5.1.2 Road & Utility Construction Feasibility

The primary challenge for road and driveway construction within the development is the prevalence of variable surface grades, even along the optimal alignments proposed with the plat layout. We expect cut-and-fill grading will commonly be necessary along the length of roadways. Most grade adjustments will be on the order of a few feet. Maximum fill thickness is anticipated to be in the range of 5 to 7 feet locally. Some road areas will also be dealing with off-camber, or cross-sloping, topography. It is recommended to build road sections in full cuts or fills, and to avoid partial cut-and-fill transitions where feasible. Where transitional areas are unavoidable, we recommend additional site preparations to properly bench subgrades for fill placement along with diligence in compaction of base materials below and along the side banks of the road to minimize the risk of future road settlement due to partial fills. Utilities constructed below partially filled roadway areas should preferably be placed at depth within underlying native soils to ensure that the integrity and performance of the line is not adversely affected.

Depending on depth of road cuts and utility installs planned, some areas may encounter bedrock before target depth of excavations. Sandstone bedrock was commonly encountered by about 4 to 5 feet depth at most test pit explorations along the entry corridor and “West Road” alignment in the north- and west-central regions of the site. Locally, bedrock was present within about 2 to 3 feet depth along the “East Road” alignment and cul-de-sac. At TP-4 in the east-central area, bedrock was found directly below topsoil. Refer to Figure 7 for illustration of depth to bedrock by test pit location. In our experience, rock excavation for utility installs and local subgrade leveling in Chuckanut Formation bedrock is relatively difficult where intact sandstone is present, and moderately difficult where rock is composed of fractured sandstone or siltstone. Conventional equipment can be used with rock breaking attachments, but the process can be time-consuming. It is recommended that subsurface data be carefully reviewed for design and construction planning so that major conflicts with rock depths can be avoided. Additional targeted explorations should be done if needed to better define depth to bedrock at certain areas for utility construction.

5.1.3 Stormwater Infiltration Design Feasibility

The project will be required to manage stormwater from new impervious surfaces in accordance with the Department of Ecology Stormwater Management Manual for Western Washington and its local municipal application. In this study, the general feasibility of on-site stormwater infiltration was evaluated in accordance with current City of Bellingham pre-permit review standards. Alternatives such as on-site dispersion and tightline outfalls were also considered.

Due to topographical and surrounding development constraints, we understand primary stormwater management for the project’s interior infrastructure and building lots will generally need to be either handled within the property, or directed via tightline down the coastal slope to the southeast shoreline for release. Stormwater management of the site in majority will most likely entail collection/detention of runoff from pavements and structures, then tightline conveyance to suitable upland dispersion areas and/or by a primary outfall pipe down to the coastline. A combination of factors such as limited lot sizes, variably sloping topography, and proximity to other homes and roads will preclude use of dispersion on most individual lots. Northerly areas of the site may drain separately out to Viewcrest Road.

While there are some localized opportunities that could be pursued for small-scale infiltration on lots, as discussed below, the predominant majority of the site is not conducive to infiltration due to shallow restrictive soil/rock conditions, potential for perched seasonal groundwater, steep grades with potential for saturation-induced instability, or a combination of limiting factors. Local infiltration, where viable, is best suited for individual lot stormwater management at select areas to be addressed with future design and construction of home sites. Aside from the localized infiltration usage, most lots are recommended to have runoff captured and routed for dispersion or off-site disposal.

Potential Residential Lot Infiltration Areas

The northwestern and north-central portion of the property in the vicinity of Viewcrest Road was interpreted from exploration data to have the best potential for per-lot infiltration. This area generally consists of approximately 1.5 to 3.0 feet of cover soil and 1.5 to 3.0 feet of glacial outwash overlying glacial drift or till. The outwash material consists of sand and gravel with a generally low fines content and relatively high natural transmissivity. Analysis of infiltration capacity for the outwash-type soils found locally is presented in Section 5.7.

The project is within the City of Bellingham jurisdiction, which stipulates that at least 3.0 feet of permeable soils and at least 1.0 feet of separation must be available for residential downspout infiltration systems to be feasible. Typical options include linear trenches or drywells. The soil profiles observed in TP-13 through TP-17 (Lots 1 to 7 area) all appear to meet or exceed these criteria, where explored. The northwest and north-central areas also generally grade down to the north, separate from the majority site topography. Therefore, stormwater infiltrated locally on these lots will not place a hydrologic load on sensitive slope areas.

Pursuant to local stormwater regulations, which dictate residential lot infiltration systems be used *where feasible*, we recommend infiltration systems be considered on these northerly lots/areas in the future during final lot design. The actual application will depend on other factors, including grading, space, and conditions at areas open for stormwater use on each lot. We recommend a contingency plan of off-site tightline disposal in the event that infiltration is found to be non-viable upon further review on a per-lot basis. A public stormwater utility is mapped along the south side of Viewcrest Road directly in front of lots in the referenced area that may be an option for off-site stormwater disposal.

5.2 Seismic Design and Liquefaction Potential

This section addresses site-modified seismic design parameters based on regional-scale mapping of Site Class and the subsurface conditions encountered in our investigation. Additionally, we address site-specific liquefaction susceptibility.

5.2.1 Seismic Design Coefficients

For structural design purposes, our assessment of site geology may be considered Site Class C, representing a dense soil and bedrock profile. For design code standards per IBC 2018, we have determined utilizing web-based design tools that the following seismic parameters (Table 3) are appropriate for design of the proposed residences. Peak Ground Acceleration values were generated based on a combination of ASCE 7-16 and IBC 2018 guidelines.

Table 3: Seismic Design Parameters

Coefficient	Description	Value
S_S	Mapped Spectral Acceleration (0.2 second period)	1.018
S_1	Mapped Spectral Acceleration (1.0 second period)	0.358
S_{MS}	Site-modified Spectral Acceleration (0.2 second period)	1.222
S_{M1}	Site-modified Spectral Acceleration (1.0 second period)	0.537
S_{DS}	Design Value (0.2 second SA)	0.815
S_{D1}	Design Value (1.0 second SA)	0.358
PGA	MCE_G Peak Ground Acceleration	0.435 [g]
F_{PGA}	Site Amplification Factor at PGA	1.2
PGA_M	Site Modified Peak Ground Acceleration	0.522 [g]

5.2.2 Liquefaction Susceptibility

Soil liquefaction is a result of loss in effective shear strength under the influence of elevated pore water pressure development during a seismic event. For soils with lower internal shear strength, earth shaking during an earthquake may cause pore water pressures to exceed the strength of the soil and “liquefy” portions of the profile. In general, saturated, loose to medium dense and cohesionless granular soils are most prone to liquefaction. Whereas high-fines cohesive and plastic soils and dense/hard soils or bedrock are not considered liquefiable. Liquefaction can induce total and differential ground settlement, surface disruptions, and lateral spreading where there is a lack of buttress or lateral support (such as near a slope or water body). Liquefaction and seismic shaking can also instigate soil slope failures where global stability of a slope is limited by shear strength. The effects of liquefaction are difficult to predict and can vary locally as evidenced by past events.

The *Liquefaction Susceptibility Map of Whatcom County, Washington* (Palmer et al., 2004) indicates the site vicinity has a negligible potential for liquefaction to occur due to the underlying bedrock geology. The mapping is based on generalizations of subsurface conditions associated with regional-scale geologic deposits, and should be considered on the site scale for potential variations based on exploration data. Our on-site findings have confirmed the map designation of no discernable liquefaction hazard at the site.

5.3 Foundation Design and Construction

For home foundation site preparations, we recommend first removing all topsoil and organic materials, uncontrolled fills or disturbed soils if present, and soft or loose cover soils down to native subgrade of medium dense/stiff or better consistency. Local over-excavation may be required to address problematic areas and variations in the shallow deposits. Recompact granular subgrades to mitigate excavation disturbance and promote a uniform density. Fine-grained subgrades should be protected from excessive disturbance and exposure limited during inclement weather conditions before foundations are installed.

Foundation excavation depths to reach competent subgrade are expected to be typical for shallow construction where building on gentle grades. Where building on grades of 3:1 (H:V) or higher, a minimum embedment of 2.0 feet is recommended for lateral stability and erosion protection. Foundation areas proposed on grades of 40% or greater are recommended to undergo site-specific review and be designed appropriately for slope-side construction. It is presumed that critical area slope evaluations will be required on a case-by-case basis for areas of steep grades.

We recommend all foundations on sloping topography be constructed directly on native cut subgrades by use of stepped footings or tiered footing levels. This will avoid the risk of differential settlement between foundations supported on native subgrade versus those on leveling fills.

5.3.1 Bearing Capacity

Assuming home site foundation areas are prepared as recommended above, a prescriptive or general **allowable vertical bearing capacity of 2,000 pounds per square foot (psf) is recommended**. This capacity takes into account the range of native soils present on site, and incorporates a factor of safety of at least 3. Values assume placement directly on medium dense/stiff or better undisturbed native subgrade. The allowable bearing capacity can be increased up to 1/3 to account for short-term transient loading such as associated with seismic or wind loads.

A greater allowable bearing capacity can be utilized where foundations will be placed directly on dense/hard glacial till or bedrock subgrades. In these cases, an **allowable vertical bearing capacity of up to 3,000 pounds per square foot (psf)** can be employed. Where increased bearing loads are planned to be used, we recommend that subgrade conditions be verified directly by site-specific evaluation as well as during construction by a geotechnical professional.

Foundations shall be sized sufficiently to meet the maximum allowable bearing load requirements, or to meet minimum size requirements per IBC requirements governing at the time of construction, whichever is larger.

Expected settlements will be largely elastic and well within structural tolerances for the proposed home structures, provided footing bearing surfaces are carefully prepared and not disturbed. Settlements should not exceed 1-inch total, nor ½-inch differential, over 50 lineal feet, within code-defined limits.

5.3.2 Lateral Resistance

Sliding resistance contribution to lateral load resistance applies to foundations placed in contact with the supporting subgrade. For application to either placement on native soils or structural fills, as conditions dictate, a coefficient of sliding friction of 0.30 is recommended for broad use. This value is function of the internal friction of the subgrade soil, and includes a factor-of-safety of at least 1.5. For well-compacted imported granular structural fills placed as foundation base fill, and for foundations placed directly on sandstone bedrock, the coefficient can be increased to 0.50.

Lateral earth pressures imparted and passive lateral resistance provided by foundation backfill are addressed in Section 5.4 Retaining Wall Foundations. The frictional forces can also be applied to restraining scenarios.

5.3.3 Foundation Drainage

The site commonly exhibits conditions with potential for shallow seasonal soil saturation and/or perched transient groundwater. Lots on lower portions of the site may be susceptible to subsurface drainage from the upland vicinity. We highly recommend use of perimeter foundation drains to promote long-term dry foundation conditions. In addition to perimeter foundation drainage, we recommend exterior ground surfaces and pavements be graded to slope away from structures. Building ancillary features should avoid those that could allow water to collect and pond against the outside of the structure. Exterior pavements and flatworks near the structure should incorporate local surface drains to control runoff.

For greatest effectiveness, footing drains should be placed even with the base of the footing along the exterior of structures. A continuous, 4-inch minimum diameter, perforated pipe that is sloped for gravity-assisted drainage and wrapped in filtration fabric or a filter sock is recommended. The area around the pipe and extending against the adjacent foundation wall should be backfilled with drain rock and separated from adjacent soils by use of soil separation fabric. Unless otherwise specified by design, the upper 1.0 foot of subsurface should be capped by low permeability fill material or pavement to minimize vertical water transmission from the building exterior to the foundation. Connect footing drains via tight-line to a catch basin or discharge facility separately from roof drains and other exterior surface drains to avoid backwards transmission or flooding of the foundation drain system by stormwater sources.

5.4 Retaining Wall Foundations

Retaining wall foundations may be used with some residences to permit construction directly against slope cuts or for daylight basements on sloping grades. In these cases, cast-in-place concrete walls of about 1-story maximum height are expected. This section provides preliminary guidelines and recommendations for structural retaining wall design and construction. Since walls will typically be employed in areas with steep slopes, we recommend lot-specific critical area reviews to confirm or modify the input as appropriate. At minimum, we recommend that Element Solutions be contacted to review proposed design plans and consult on specific applications in the absence of additional investigation.

5.4.1 Lateral Earth Pressures

Wall features in lateral contact with soils are subject to earth pressures and resistances from native soils (cut locations), or as a result of backfill materials placed against them (fill conditions). Recommended static lateral earth pressures (active and at-rest) are summarized in Table 4 (provided as equivalent fluid weight, units psf/foot or pcf). For the seismic design case (^), experience has shown that retaining wall structures perform very well based on designs employing the at-rest earth pressure loading pressures. The provided values assume fully drained conditions and increase linearly with depth. *Undrained design situations must also account for hydrostatic pressure with correspondingly increased values; contact Element Solutions for consultation on design using undrained conditions if required for the project.*

Table 4: Lateral Earth Pressures by Soil Type

Soil	Condition	Soil Unit Weight (PCF)	Active (EFW)	At-Rest [^] (EFW)	Passive Lateral Resistance (EFW)
Native Soil (SM – ML) (Silty Sand-Sandy Silt)	Retained	115 - 125	40	60	375* (static) 300* (seismic)
Structural Fill (GP)	Backfill	125 – 135	30	50	600* (static) 500* (seismic)

Values in Table 4 do not include additional pressures imparted from sloping backfills, vehicle loads, temporary stockpiles, or loads from nearby structures. Wall designs must account for adjacent surcharge loads in addition to the model lateral earth pressures. Structural Fill values will typically apply where walls are used to build up from existing grades. The exception is for walls constructed closely to and in part against native soil cuts. In that case, where backfill width is less than wall height, we recommend using the Table 4 earth pressure values corresponding to native soils.

The passive lateral resistance values for soils in Table 4 are unfactored values*. Appropriate factors of safety should be applied when using passive soil resistance to reduce the parameter to the acceptable design value. We recommend safety factors of 3 and 2 be applied under static and seismic conditions, respectively. For backfills providing passive restraint and extending at least 3.0 times the wall foundation depth horizontally from the foundation, values for compacted structural fill can be used. For lesser supporting widths of structural fill, and for foundations placed “neat” against undisturbed and competent native soils, the corresponding native soil parameters should be applied for passive resistance. All passive restraint values assume a horizontal surface for the supporting soil, and sloping surfaces must be evaluated on a case-specific basis.

5.4.2 Wall Construction Recommendations

A dedicated wall drain system is necessary to promote backfill drainage and minimize hydrostatic pressures behind walls. All walls are recommended to incorporate foundation drains as specified in 5.3.3 Foundation Drainage. In addition, backfill for the first 12 inches minimum behind walls is recommended to consist of fully free-draining material, such as Gravel Backfill for Drains (WSDOT SS 9-03.12(4)), or approved equivalent. We recommend placing filter fabric between the drainage corridor and backfills or retained soils to limit fine material from entering the free-draining zone.

Sealing of home foundation retaining walls with waterproofing treatment is advisable if low levels of potential leakage over time is unacceptable; without treatment, some through-wall transmission during heavy flows should be expected.

We recommend relatively free-draining gravel backfill be utilized within 5 feet of retaining walls. Free-draining materials have a typical maximum of around 3% fines content (depending on material type), and thus standard structural fill may not be suitable. Retaining wall backfill should comply with WSDOT SS 9-03.12(2) Gravel Backfill for Walls, or approved equivalent.

Backfill placed near walls (within about 5 feet) should be compacted with appropriate small equipment to avoid excess compaction leading to potentially elevated earth pressures. Place and compact fills in approximately 6-inch lifts while working progressively further from the back of the wall. Backfill should be delayed until the wall concrete has cured to acceptable strength.

5.5 Slab-On-Grade Floors

A slab-on-grade floor may be used for portions of the home structures. Loading is anticipated to be light residential use; no heavily trafficked or loaded areas are expected. Any slabs that will be subject to high loads or heavy vehicle traffic are recommended to be designed as rigid pavement sections with adequate slab thickness, reinforcement, and base materials for the expected use.

5.5.1 Slab Preparation and Construction

For slab-on-grade areas preparation, we recommend all organic soils and unsuitably loose or soft soils be removed. Granular subgrades should be recompacted after stripping to a uniformly medium dense or better condition. Fine-grained subgrades should be verified as suitably stiff and unyielding. We recommend a proof roll be conducted on slab subgrades, if weather conditions and access permits, prior to capping with structural fill. Any areas identified by proof roll to be loose, soft, or pumping are recommended for over-excavation and backfill with structural fill.

For the encountered site conditions, we recommend installing a base pad of at least 6 inches minimum thickness below floor slabs. This will promote under-slab drainage and provide stabilization over shallow moisture-sensitive subgrades. Slab base fill is considered structural fill, and should comply with the recommendations below for material type and installation. A properly compacted angular crushed-rock capillary break using structural-quality material (Section 4.4.2) can account for the recommended base section.

Assuming diligent subgrade preparations and recommended base pad installation, we recommend slab design use an allowable Subgrade Modulus (k) of up to 125 pci for design of light-load interior floor slabs.

5.5.2 Slab Drainage and Moisture Control

All interior slab-on-grade floors are recommended to be underlain by a capillary break section composed of appropriate free-draining material. For this purpose, we recommend a 6-inch minimum section of uniformly-graded, low-fines content, angular, clear crushed rock be placed and compacted to a dense and unyielding condition. Capillary break material is recommended to contain at maximum 3 percent fines (amount passing U.S. #200 Sieve) and be composed of 3/4-inch to 1.0-inch clear crushed rock material with nominal content passing the U.S. #4 Sieve. Where composed of approved structural-quality material (as recommended), it can account for the slab base pad.

A vapor barrier is also recommended below interior floor slabs. To inhibit moisture transmission through the slab where floor coverings can be impacted by moisture, we recommend placing a 10-mil or thicker polyethylene membrane below the slab. The barrier should be placed to overlap between sheets and properly sealed at the adjoining edges. The installer should take care not to damage or puncture the membrane during or after placement to maintain its integrity.

5.6 Pavement Recommendations

General recommendations for geotechnical site preparation and earthwork construction are provided in the sections below. In this section, we provide site- and project-specific recommendations and commentary for design and construction of proposed pavement areas.

5.6.1 Pavement Design Considerations

The site soil conditions are considered typical for asphaltic pavement section support. We recommend the standard City of Bellingham Pavement Section criteria for the road classification be applied for new public roadways. For private, light duty access roads and driveways, we recommend the following minimum asphaltic pavement section:

Light Use Private Areas*

Asphalt (HMA Class B)	3"
Gravel Base (CSTC/CSBC or Gravel Borrow)	6"

* For private roads required to allow heavy service vehicles or emergency vehicles, a 12-inch minimum total pavement section is recommended.

These sections are intended only as guidelines for design. Sections should be verified as suitable for the final development plans and adjusted if needed by the design engineer.

5.6.2 Pavement Construction

Preparations for new pavement and exterior flatwork areas should generally follow the subgrade preparation recommendations in Section 5.8 and typical industry practices. Given the extent of the project area and the range of conditions observed, some variation in stripping depth should be anticipated to reach suitable subgrade conditions.

Subgrade for new pavement sections and flatworks should consist of generally stiff or medium dense native soils, or compacted approved fill installed over suitable native subgrade. Shallow subgrades will generally consist of silty sands and sandy silts of varying content. Granular subgrades should be lightly recompacted to establish a suitably uniform and medium dense state. Fine-grained subgrades should be prepared with a smooth finishing bucket to limit disturbance.

It is important to carefully assess pavement subgrades for suitability. Subgrade assessment should be done by a qualified geotechnical professional. We also highly advise conducting proof rolls of pavement subgrades, as proof rolling is well suited to identifying areas of problematic (weak) subgrade when under traffic loading. Any yielding or pumping areas identified should be over-excavated to remove under-performing subgrades and backfilled with gravel base material.

In cases where pavement subgrade is marginally suitable and additional excavation is not viable, or does not reach improved conditions within a reasonable depth, a geotechnical professional can assess the need for a minimum excavation depth for stabilization. Measures to stabilize poor subgrades will typically include specifying a certain structural fill replacement to “bridge” the weak conditions at depth, and/or placement of a ground fabric or geotextile for separation/structural purposes. The type and specification of subgrade reinforcement should be determined per the conditions at a given location. For situations requiring a lesser level of stabilization, a separation and filtration fabric may be sufficient (such as Mirafi 140N or 160N fabric). For heavier uses, an extruded polypropylene biaxial geogrid (i.e. Tensar BX series or similar) is recommended.

5.7 Stormwater Infiltration

Samples of outwash-type soils were collected from several explorations in the northwest and west-central areas of the site, and analyzed for grain size distribution with results as summarized above (Section 3.2.2); complete lab testing reports are attached in Appendix II. Saturated hydraulic conductivities (K_{sat}), representing infiltration rates, were then estimated using the Washington Department of Ecology Stormwater Management Manual (DOE SWMMWW, 2019) grain size analysis method. Rate calculations were performed using the grain size distribution data from lab testing (D10, D60, D90, and % Fines values). These variables were input into the following equation as adapted from Massmann, 2003 and Massmann et al., 2003:

$$\log_{10}(K_{sat}) = -1.57 + 1.9D_{10} + 0.015D_{60} - 0.013D_{90} - 2.08f_{fines}$$

$$K_{sat\ design} = K_{sat\ initial} \times CF_t \times CF_v \times CF_m$$

Correction factors in the second equation were used to translate initial Ksat value to a corrected Ksat. We applied typical correction factors of 0.40 (CF_t) for grain-size test method and 0.9 (CF_m) for degree of influent control. A general value of 0.5 (CF_v) for site variability was applied to account for level of variation in fines content and consistency/density of the soils as observed, which may not

be fully reflected in the samples analyzed. The total correction factor applied was $CF_T = 0.18$. Laboratory inputs and corrected Ksat values per sample location are presented in Table 5:

Table 5: Infiltration rate calculation results (Massmann Grain Size Method)

Loc.	Depth (ft bgs)	Class.	D10	D60	D90	Fines %	Ksat (in/hr)	Corrected Ksat (in/hr)
TP13	4.0	GP	0.64	12.22	27.16	1.5%	395	71.1
TP16	3.0	GP-GM	0.26	11.78	38.90	5.3%	43	7.8
TP24	4.0	SP-SM	0.11	4.94	25.59	8.3%	23	4.1

The samples analyzed were selected to represent the range of variability in the local outwash deposits observed in portions of the site. Generally, these granular soils contained fines contents in the range of 5% to 20%, and typically around 10% or less. The level of fines most directly affects the calculated Ksat value. Samples from TP13 (4 feet bgs) and TP16 (3 feet bgs) were chosen to represent gravel-rich soils at the low and moderate end of the average fines content spectrum, respectively. These soils found locally are highly transmissive and favorable for infiltration. The sample from TP-24 (4 feet bgs) better represents the sand-rich version of shallow outwash-type soils on site.

As expected, the gravel-rich samples with low fines yield a relatively high Corrected Ksat value which is subject to significant variation depending on local gravel and fines content. Whereas, the sandier deposits are typically more predictable for rate determination. For preliminary design purposes, we recommend design values not exceed the lower range of results. ***A Corrected Ksat of up to 4 inches/hour maximum is advised for use in preliminary design of select residential stormwater features with infiltration depths corresponding to outwash soils.***

We also reviewed the infiltration soil classification using the alternative USDA Classification System (MO5 Soil Technical Note 16; Benham et al., 2009) which is commonly used for prescriptive sizing of residential trench and drywell systems. The USDA method excludes the sample fraction retained on #10 sieve (gravel portion) and uses adjusted boundaries of sand sizes. The outwash soils sampled are classified as **Coarse Sand** per USDA textural criteria. Some notably sandier variations of the unit may be better classified as Sand. The designer may elect to use prescriptive design sizing for drywells based on DOE SMMWW (2019) standards. Actual soil conditions at the system location and depth should be reviewed to confirm final sizing criteria.

Samples of outwash soils from TP-13 and TP-24 were also tested for treatment-related properties. Samples recorded a **Cation Exchange Capacity (CEC) of 3.9 and 6.2 meq/100g** and an **Organic Content of 1.5% and 1.4%**, respectively. Organic Content values are found to exceed the 1.0% organic content requirements per the 2019 DOE SWMMWW. However, CEC values for native soils are near the 5.0 meq/100g minimum standards for CEC treatment requirements. Results are above or below the threshold corresponding to the local content of granular material, higher for sand and lower for gravel. If treatment is required, native soil amendment or import of an engineered treatment media may be necessary.

Design Commentary

The tabulated (Table 5) preliminary design rates appear suitable for small-scale infiltration of rooftop stormwater where outwash conditions are present. We assume single residence systems would consist of prescriptive downspout infiltration features, either drywells where depths allow or shallow trenches where transmissive soils are depth-limited. Alternatively, a civil designer can be employed for engineered design of a lot-specific system.

Shallow soils at the northwest area entailing Lots 1 to 7 also appear to be suitable for pervious pavement use. Topsoil/subsoil in that area was observed to range from 1.5 to 3.0 feet thick. Below the thick cover soils, the subgrade was sandy soil. The above corrected design rate is suitable for pervious pavement design in this area. There may be similar opportunity for small, localized, stormwater systems servicing driveways, as well as pervious pavements/flatworks, that can be evaluated during individual lot designs at other locations. The current exploration data can be used as a general guide to identify potential infiltration areas. To confirm or adjust values for final design use, we recommend additional targeted explorations at specific locations/areas proposed for stormwater infiltration or pervious pavement use.

On the majority of lots where on-site infiltration and direct release is infeasible due to steep slopes, shallow bedrock, or other restrictions, stormwater should be collected and tight-lined to an approved dispersion location or to a community shoreline outfall pipe.

We recommend conditions be confirmed and systems be best fit on individual lots proposed for infiltration at the time of future lot development. The results of this feasibility-level review are suitable for general planning purposes, but are not intended to provide final design recommendations for individual lots without further review.

5.8 Earthwork and Excavations

5.8.1 General Site and Subgrade Preparation

We recommend stripping and removing topsoil, unsuitably soft or loose subgrades, uncontrolled fills, and soils containing organic remains or other deleterious materials. Stripping should include all proposed structure and pavement/flatwork improvement areas, and areas receiving structural fills to raise grade below or proximal to structures and pavements.

Once subgrade level is reached and any remaining unsuitable materials are removed, granular subgrades should be recompacted to a suitably dense, uniform, unyielding condition. We recommend subgrades beneath structures and pavements be evaluated by a geotechnical professional by appropriate means including T-probing and visual assessment to confirm competent unyielding conditions are established. Where unsuitable soils are identified, additional stripping or over-excavation and replacement with structural fill should be conducted under guidance of the geotechnical consultant.

A proof roll should be conducted over prepared subgrade with a loaded single-axle dump truck or water truck, or other appropriately sized and loaded equipment, under observation of a geotechnical professional. When access is not feasible, or weather conditions do not permit a proof roll, alternative means can be used to verify subgrade adequacy at the discretion of the geotechnical

consultant. If areas of excessive deflection/rutting, looseness, or pumping are identified by proof roll, mark locations for rectification. Loose or rutting areas can be recompacted, subject to suitable moisture conditions, then re-assessed for suitability. Any pumping locations or persisting loose/soft areas likely reflect excessive moisture conditions and should be over-excavated until reaching suitable support conditions (or alternatively stabilized as directed by the geotechnical professional), then backfilled with new imported structural fill to restore planned subgrade level.

For over-excavations below structural loads, the width of excavation at base level is recommended to extend a 1H:1V distance outside of the loaded location corresponding to the depth of over-excavation. For instance, an over-excavation of 1 foot should also extend 1 foot in each direction from the edge of a structural load.

5.8.2 Difficulty of Excavations

The native soil conditions encountered at shallow levels (within a few feet of the surface) are anticipated to be viable for excavation and site preparations using traditional mechanical equipment (such as excavators/backhoes, bulldozers). Tooth-edge buckets may be preferable for excavation of dense or cemented materials as encountered. Flat-edged buckets should be used when preparing fine-grained subgrades to lessen disturbance of the subgrade, and when trimming excavation bases to final foundation design grade.

The depth to bedrock is found to vary within the project area, and in some cases is notably shallow. It is likely that conflicts with bedrock will arise when constructing infrastructure. Chuckanut Formation bedrock can typically be excavated with difficulty for road grading and utility trenching using standard equipment and mechanical rock-breaking equipment. Blasting is not recommended due to the potential for blasting to impact stability of adjacent sloping areas.

5.8.3 Wet Season Construction

Shallow native soils at the project site consist of silty sand to sandy silt with elevated fines content. These types of soil are highly moisture sensitive, and prone to significant issues such as weakening and degradation as a result of exposure to wet weather in the presence of construction traffic and activities. Furthermore, earthwork activities on moisture sensitive conditions can be difficult with additional costs and time commonly incurred for wet weather construction. Moisture-sensitive soils can be difficult to work and manage even in the dry season during periods of inclement weather. Finally, we recommend against placing frozen soil as fill, and against placing fill over frozen subgrade. Therefore, it is preferable to perform major earthwork construction for this project in the drier/warmer part of the year (late spring to early fall), and to avoid major grading activities during wet weather as possible.

For project earthwork activities that take place in the winter season or in inclement weather, we recommend the following guidelines:

- Limit machine and truck traffic on exposed subgrades to only as necessary. If traffic through an area is unavoidable, consider capping with temporary stabilizing material and/or leaving stripped levels high to be trimmed to grade later.
- Be prepared to substitute native material use (if planned) with imported structural fill. Be prepared to change imported materials to a low-fines content free-draining aggregate or clear rock substitute if moisture cannot be adequately controlled.

- Grade subgrades for runoff, and provide outlets or dewatering for confined excavations that are susceptible to water inundation from runoff or seepage.
- Implement controls to the extent possible to limit surface runoff from adjacent areas from entering the excavation or work area.
- Avoid directing temporary runoff or water diversions from excavations onto nearby steeply sloping grades.
- Plan and conduct work in stages to minimize open time for sensitive subgrades. Preferably, strip and cover moisture-prone subgrades quickly if working in rainy weather.

5.8.4 Excavation Dewatering

Shallow conditions were generally free of wetness in the summer season, as seen in the test pit exploration logs. However, perched groundwater was observed locally, and shallow restrictive conditions are commonly present. This indicates a potential for seasonally induced seepage and water transmission through the shallow subsurface. While development of a full perched water table is unlikely given the sloping grades of the site, migration of shallow transient water from uphill sources into excavations may be expected to occur in the winter and spring seasons. Perched water may collect locally in topographically convergent areas.

Dewatering actions may be needed to maintain workable shallow excavations if site preparation or utility work is done in the wet season or under sustained wet weather. We anticipate conventional methods should be sufficient for controlling transient water inundation, including pumping for evacuation and providing temporary runoff outlets from work areas. Some additional expense and difficulty should be anticipated for wet season site preparation and utility construction.

The scope of work completed to date has not included direct monitoring of groundwater fluctuations through the wet season, or characterization of flow rates/volumes for subsurface water transmission. A hydrogeologic study has not been conducted at this site. The information and commentary provided is intended only for planning purposes, and does not necessarily provide recommendations for dewatering design.

5.8.5 Excavation Shoring

In Washington State, shoring or sloping is required for excavations that are deeper than 4.0 feet (WAC 296-155, Part N). Excavations for this project are anticipated to be primarily shallow, although some work may call for depths in excess of 4 feet. If shoring is elected due to space constraints, or as the preferred method of construction, the system must be evaluated and designed by a registered professional engineer licensed with the State of Washington. The shoring designer should review the findings of this report, and account for potential loads including soil pressures (active or at-rest, as applicable), hydrostatic influences, and loads from sources such as adjacent stockpiles, heavy equipment, and traffic.

In addition to providing safe excavation access and egress in accordance with OSHA requirements, shoring should be designed to adequately protect adjacent features (such as existing utilities, structures, pavements) from detrimental effects including during installation and removal of the shoring. In the event that shoring is required in proximity to an existing feature/facility, we recommend the standards for protection be clearly established in project requirements. In some

cases, an acceptable level of damage to adjacent conditions is suitable in order to expedite work. The standards for repair to existing features as a result of excavation shoring use should also be agreed upon prior to construction.

5.8.6 Temporary Cut-slopes

We recommend all temporary construction slopes adhere to local, state, and federal requirements. Establishment and maintenance of suitable cut-slopes to provide worker and site safety is the responsibility of the contractor. The following guidelines for cut-slope preparation are provided for general planning purposes only, and should be revised as necessary once conditions are open and observed during construction.

Temporary cut-slopes within the shallow native soils should be sloped no greater than 1:1 (H:V), corresponding generally to “Type B” soils. If soils are locally soft or loose with apparent instability, or if work proceeds in wet conditions, a down-grading of the soil type and corresponding reduction to 1.5:1 (H:V) or less is recommended. Excavations can be evaluated in construction by a qualified geotechnical professional to determine if steeper grades are permissible for short-term and/or relatively small slopes based on actual observed condition and soil strength.

Loads from external factors, including but not limited to heavy equipment, traffic, stored materials, and soil stockpiles should be avoided directly above unreinforced cut-slopes. If loading is unavoidable, a lesser slope angle or temporary shoring of the location may be necessary. We recommend cut-slopes that will remain open for an extended duration be protected from exposure to inclement weather conditions. Covering slopes with plastic can help prevent erosion and degradation of the slope face over time. If utilized, cover sheeting should be anchored sufficiently to resist wind displacement and overlapped to minimize leakage.

5.9 Structural Fill Recommendations

5.9.1 Use of Structural Fill

Structural fill constitutes all fill soils placed underneath structures or pavements for support. Additionally, soil backfills against foundations and walls, and soils used similarly for the purpose of providing lateral stability to structures, are considered structural fill.

In general, structural fill shall consist of primarily granular and non-plastic aggregate of suitable gradational characteristics, that is relatively uniform in mineral composition, contains no discernible organic materials, and is free of other trash and deleterious materials. It is typically recommended that all aggregate be less than about 4 inches in diameter, maximum particle size. For thin lifts or specific applications, a lesser maximum size may be required (maximum particle size of 2/3 lift thickness, or as specified for use).

We recommend structural fill be placed over suitably prepared and engineer-verified subgrade as recommended above. We advise against placing structural fills intended for building and pavement support over existing unverified uncontrolled fills, or unsuitable soft or loose subgrades, due to the elevated risk of settlement of underlying strata. In exceptions, fills may be placed as an approved subgrade stabilization measure under the evaluation and guidance of a geotechnical professional for an express location and purpose.

5.9.2 Installation and Compaction

Structural fills should be properly moisture controlled or conditioned to within 3 percent of optimum moisture level for the specific material to encourage proper compaction. In the dry season, granular fills residing in stockpiles may be excessively dry and need to be wetted prior to or during use. In this event, it is advisable to proceed cautiously with water application until a moisture-conditioning program can be established. In the wet season, care should be taken to protect structural fill stockpiles from rainfall. Fills with excessive moisture levels must be removed and mixed, stored, or dried/aerated until within an acceptable range for use.

Installation of structural fill shall be done in horizontal lifts not exceeding about 8 to 10 inches maximum loose-thickness. Thin lifts will be needed for small machinery or hand-operated equipment in order to achieve compaction. Per *WSDOT Standard Specifications 2-03.3(14)* and our professional judgment, fills should be benched when placed on grades steeper than 3H:1V.

Structural fills shall be compacted with appropriately sized equipment to a uniformly dense and unyielding condition. For all fills placed beneath or as backfill for structures, we recommend a minimum 95% compaction be attained. A minimum compaction standard of 95% is also recommended for the upper 2.0 feet of pavement subgrades, as well as the upper 4.0 feet of utility trench backfill beneath paved areas. Beyond 2.0 feet below the base of pavement away from structures (4.0 feet at utility trenches), and for non-structural utility backfills (outside of paved areas only), a minimum 90% compaction is considered suitable. Compaction shall be based on the maximum dry density of the material, determined by laboratory testing per ASTM D-1557 test method. Field compaction testing shall be conducted as necessary to verify compaction of each lift. Compaction testing should be performed frequently as work begins to establish suitable placement/densification methods, then as needed to assure project standards are met.

5.9.3 Existing Material Suitability

On-site soils encountered in explorations consist predominantly of silty sand and locally sandy silt at shallow levels. Assuming construction in dry conditions, excavated non-organic native soils produced in cut areas are generally considered suitable for use as non-structural grading fills in landscaping areas, and as native material for trench backfill outside of the road prism (per *WSDOT SS 9-03.15*). That is, provided the material is of sufficient quality and condition to be compactable and meet other project requirements for the intended use.

Granular native soils may be suitable for use as subgrade-level fill below lightly loaded floor slabs and pavements. Site soils are moderately to highly moisture sensitive due to high fines content, and as such will only be suitable for reuse in dry weather. Native materials may need to be moisture-conditioned prior to placement. Native soils proposed for reuse on site should be stockpiled separately from unsuitable materials, and evaluated for suitability before installation by laboratory testing and/or visual means of approval. Additional testing and quality control efforts should be expected for use of native soils in comparison to imported fills.

5.9.4 Imported Material Specifications

Imported aggregate meeting plan requirements for the intended use, and the general recommendations of this report, is considered suitable for use as structural fill. For general-use structural fill, we recommend well-graded imported material meeting the specification for Gravel

Borrow (*WSDOT SS 9-03.14(1)*). A performance equivalent may be approved for substitution by the project engineer and geotechnical consultant.

Gravel backfills placed behind retaining walls and retaining foundations must be free-draining, and shall comply with *WSDOT SS 9-03.12(2)* unless otherwise specified or approved by the wall design engineer. Free-draining materials have a typical maximum of around 3% fines content (depending on material type), and thus standard structural fill may not be viable for this purpose.

If work occurs during excessively wet weather, or if water is unavoidable within excavations, it may be preferable to substitute standard structural fill with a material not affected by water presence. For this purpose, a clear angular rock such as 1-1/4" clear ballast may be considered, subject to approval by the geotechnical consultant for the proposed use. If utilized, clear rock shall be installed as recommended above and compacted to an unshifting, unyielding, and uniformly dense condition as verified by visual methods and/or proof-roll.

Controlled-density fill (CDF) may be suitable for use in substitution for structural fill in some cases. If proposed, CDF use should be reviewed by the project engineer and geotechnical consultant before its placement.

Laboratory testing should be conducted in advance of construction to evaluate and verify the proposed imported materials are suitable for use. In the event that a material does not meet the project specification, the applicable engineer and geotechnical consultant may review the results for conditional acceptance. However, the contractor should also be prepared to find an acceptable alternative material if the initial source is unsuitable.

5.10 Utility Construction

5.10.1 Utility Trenching and Excavation

Trenching and excavations for utility improvements will typically encounter topsoil and shallow glacial deposits or colluvium (locally variable sand, silty sand, and sandy silt) through a few feet depth. Upper deposits are underlain at varying depth by cemented/densic glacial soils and bedrock of the Chuckanut Formation (Sandstone, Siltstone). We have made the following inferences based on conditions encountered:

- The native upper soils are considered moderately susceptible to raveling and sloughing on average. Actual degree will vary locally by soil type. Steep trench walls may be difficult to maintain for even shallow excavations. At minimum, a contingency plan for slope layback or temporary reinforcement should be in place, especially for trenching in limited space.
- If trench work is conducted during wet weather, seepage from perched water and soil saturation may increase the likelihood of trench wall raveling/sloughing.
- Due to the potential for shallow saturation and seepage as well as inundation from upgradient transient waters into confined excavations, trenching and utility work is generally not recommended to be done in the winter season.

- Bedrock presence at shallow depth can significantly hinder the timing and progress of trenching preparations. Additional potholing is recommended to be done during construction for pre-planning purposes as the project advances.

The longitudinal extent of trenching should be kept to short intervals or segments, with pipe installation and back filling completed prior to opening new trench sections. This will limit the length of exposure time to trench wall drying or rain-wetting with the consequent sloughing that may be expected with exposure time.

It is the responsibility of the contractor to establish a safe and secure work environment for entry and work performed in utility trenches. The recommendations in the Earthwork and Excavations section of this report should be followed, as well as any state and federal safety regulations. The contractor is also responsible for monitoring the condition and safety of excavations including utility trenches over the open time. In the event of instability or signs thereof, the contractor should be prepared to modify the excavation to a more stable configuration (by using or reducing cut-slopes) or utilize temporary shoring. It shall be understood that conditions can change and local variations can occur. The above guidance is intended for general planning of trench work, and does not represent a guarantee of conditions or the success of specific approaches. Any significant variation from the above encountered during construction should be reassessed by a qualified geotechnical professional.

5.10.2 Backfill and Pipe Zone Bedding

Typical trench and pipe backfilling practices are considered appropriate for this project. As is noted above, some materials excavated during trenching for this project may be suitable as replacement trench backfill in select areas. The material should be evaluated for its suitability upon excavation but before it is planned for reuse. The following recommendations are provided for trench back fill and pipe zone bedding considerations.

- Imported gravel for pipe zone bedding should consist of aggregate material satisfying the specification requirements of *WSDOT 2018 Standard Specifications 9-03.12(3)*.
- Unless otherwise specified by project or local municipal utility requirements, imported gravel for trench backfill below roadways and beneath paved areas should at minimum meet the specification requirements of *WSDOT 2018 Standard Specifications 9-03.19*. If allowed, trench backfill outside of paved and trafficked areas may consist of suitable native or other non-structural material (per *WSDOT SS 9-03.15*).
- Based on the interpreted suitability of native subgrades at likely utility trench depths, it will not be necessary to use an additional foundation layer when constructing utilities at the project site.
- To limit potential future settlement of pavement sections above newly installed utilities, compact the pipe bedding zone material to not less than 95% of its maximum dry density. If a “self-compacting” material is used (such as pea gravel), the material should be well distributed and tamped as needed to achieve an unyielding condition before backfilling.
- For trench backfill below pavements, it is preferable that the level of compaction achieved is at least 97% (no less than 95% standard minimum). However, the pipe manufacturer’s

specifications for compaction of materials adjacent and above the pipe should be observed to prevent possible damage to the pipe and any connections.

We recommend against using alternative soil densification measures such as jetting or flooding as a substitute for proper mechanical backfill compaction. Utility backfills and compaction procedures should adhere to the recommendations provided in this report for Structural Fill.

Where lateral thrust blocks are to be constructed to provide lateral pipe restraint, the concrete should be cast neat to undisturbed trench wall soils to ensure that adequate lateral load support is provided by the in-situ soils. Backfill placement for support of thrust blocks is not recommended.

5.11 Contractor Responsibilities

Some variability in substrate composition should be anticipated across the study area. It is not plausible or reasonable to expect that a pre-construction investigation will identify all variations at a site, nor does the exploration program executed for the purpose of this study constitute a complete and exhaustive survey of site subsurface conditions. A reasonable level of extrapolation has been applied to the interpretations and conclusions of this report. The contractor is responsible for reviewing this information in full, and asking for clarifications, if necessary, prior to conducting work. The contractor should also conduct independent confirmation of conditions as needed to successfully plan and implement their proposed systems of construction, including but not limited to shoring and dewatering design, if required. If the opportunity to conduct additional evaluation is presented and waived by the contractor, neither the client nor Element Solutions shall be held liable for data limitations in design of construction systems and methods.

In all instances where unusual or unanticipated subsurface conditions are encountered during any stage of the site preparation or construction process, it is the responsibility of the construction contractor to notify the client and/or the engineering design team. The project team should then be prepared to provide on-site geotechnical supervision prior to further excavation, grading, or construction. Due to the compositional variability observed in shallow soils across the site and the potential for excavation and trench caving, a geotechnical engineering professional should be consulted as needed during all temporary excavations to confirm soils and excavation/trenching conditions.

All on-site soil excavation and stockpiling should be performed in accordance with industry-standard best practices and protected from erosion in a manner consistent with the approved Temporary Erosion and Sediment Control (TESC) Plan. The contractor is responsible for implementing and maintaining erosion control procedures and devices in accordance with local and state requirements.

5.12 General Critical Area Guidelines & Recommendations

The following guidelines and recommendations are intended to minimize the impacts and inherent risks associated with development within or in proximity to geologically sensitive critical areas. The information is site- and project-specific based on our understanding of the proposed development and existing conditions at this time.

5.12.1 Stormwater Management

Development drainage features and stormwater controls should be implemented in a manner that does not lead to an increased potential for erosion or instability on the site slopes, nor places downgradient properties at risk. Generally speaking, ***we recommend that all stormwater from new impervious surfaces be captured and managed.*** On-site stormwater release systems (infiltration or dispersion) for lots or roadways are not considered viable among areas on or proximally above steeply sloping topography. With exception of localized lot-scale infiltration at areas of the property fronting Viewcrest Road, and possibly pervious pavement driveways at some other lots to be determined, the site is generally considered infeasible for infiltration. The combination of small lot sizes and sloping topography also appears to limit use of individual lot dispersion systems within most of the building lots.

Project discussions indicate the primary stormwater management for the site roadways will employ subsurface storage volume (i.e. vaults, large pipes, stormtech units, etc.) for flow control. One option under consideration for disposal is to collect and route stormwater to the eastern part of the site, then convey it downhill to the southeast via a big outfall pipe for release at the coastline (above marine water level). In our opinion, this is a viable course of action from a geotechnical and geohazard protection perspective, assuming the downslope tightline is properly sited and constructed to minimize risk of failure.

A second option, which may help to avoid construction of a large outfall pipe down the steep coastal slope, is to employ upland dispersion at select areas. Dispersion is considered among forested open-space areas of relatively lower gradient topography downhill of the main development area. In our opinion, selective dispersion is also a viable strategy provided the systems are preferentially sited and adequately designed/built so that stormwater is discharged over a sufficiently large area.

Based on the findings of this study, we conclude and recommend the following criteria for proper management of new stormwater generated by lot and roadway development:

- Infiltrate stormwater only where conditions are proven to meet municipal feasibility criteria, and steep slopes are not present or in proximity. Additional lot-scale review to confirm infiltration suitability with respect to final development plans is advised.
- Dispersion or down-gradient release of collected stormwater within individual lots is generally not advised. Underlying properties and slope areas could be negatively affected by release of stormwater.
 - Possible exceptions include lots along the southeast perimeter of the development that contain areas of gentle downslope topography (see below).
 - Depending on final development layout, there may be other exceptions of lots viable for localized dispersion. We recommend reviewing individual lot dispersion on a per-case basis, in the context of final layout and surrounding conditions, if considered for use.
- Dispersion of collected lot and/or roadway stormwater can be considered among downhill forested areas of the site. For on-site dispersion, we recommend:
 - Divide dispersion to utilize several areas so that stormwater release is not excessive at any one area, and for ease of design/construction among variable grades.

- Employ systems which control and disperse outflow over a wide area (such as a trench with level-spreader). Do not use point-source outflows in upland areas.
- Disperse among areas with lesser grades and adequate vegetation.
 - We recommend limiting dispersion to areas around 30% grade or less.
 - Avoid or minimize clearing of forest vegetation, including trees and undergrowth, around and downhill from dispersion locations.
- A minimum setback of 100 feet is recommended for engineered dispersion above the southeast coastal bluff slope.
- Based on these guidelines, areas with potential suitability for communal dispersion may include:
 - Lower gradient slope areas along the bottom of Lots 28, 29, and 30 to 32, as well as the bordering upland part of “Open Space Tract A” outside of the recommended setback.
 - Gentle mid-slope area of Lot 33, lower half of Lot 34, and adjacent ROW (to be vacated).
 - Area along east borders of Lot 35 and 36 (drains towards wetland zone).
- Element Solutions should be retained to consult on the placement and design of on-site dispersion systems, if incorporated. ES can assist in identifying optimal locations, and perform field reconnaissance for verification of suitability at proposed dispersion areas.
- All stormwater from roof runoff, pavements, and exterior drains should be tightlined from the collection points to a lot catch basin, then directed to a conveyance tightline leading to the approved dispersion facility or outlet point.
- Foundation and wall drains should be conveyed separately from other drain sources, or adjoined at a suitable down-gradient location, to prevent the backflow of water to footing drains. Given the low volume of these features, it is commonly permissible to outlet footing or wall drains at a suitably gentle and vegetated area away from the structure.
- Stormwater from upland and neighboring sources should also be properly controlled by the adjacent (off-site) properties. If necessary, construction of the project should also implement safeguards at its boundaries to lessen the potential for overland flow from entering the property. This may include incorporation of small swales, yard drains or perimeter drain systems to maintain a dry site.
- All above-grade tightlines should be composed of sturdy rigid material resistant to damage (such as PVC or welded HDPE pipe), sized adequately for the anticipated outfall volume, and anchored sufficiently to the ground to minimize the potential for damage and failure. Tightlines should be inspected periodically, and repaired or replaced as needed to maintain a safe working condition. For directed outfalls, appropriate energy reducing features should be used at the release point as necessary to minimize erosion. Examples include a perforated T-stub/spreader pipe, rock pad, or release onto exposed bedrock.

5.12.2 Site Management During Construction

Additional care is necessary when construction occurs on or near steep grades. For the purposes of critical area protection and erosion management, grades of 30% or over are subject to regulation under City of Bellingham Code. The following guidelines and recommendations pertain to regulated slope areas.

- Outside of structural areas, new fills on slopes should be minimized (other than as needed to backfill ancillary areas around footings, and below hardscapes). Fills placed on a slope face outside the confines of a structure add weight to the slope, and may increase the risk of instability or erosion.
- Temporary stockpiling of excavated material or fills, or storage of heavy construction materials and machinery, shall be avoided on sloping areas. Stockpile soils for import/export at the lowest gradient area available pending transport or use.
- Construction practices shall take care to disturb or impact as little area as possible. Impacted areas should be restored with top-dressing and appropriate plantings for the environment following construction. Avoid disturbance outside of the established development boundaries on each lot.
- Temporary erosion controls:
 - Systems and procedures should be put into place as appropriate for the site, project, and timeframe/season of construction. TESC measures should include downslope and sideslope clearing/disturbance limit barriers or demarcations.
 - During periods of major excavation and during benching or excavation of rock on or near sloping grades, additional downslope safeguards should be installed as needed to prevent soil and rock fall from leaving the site.
 - The contractor is responsible for implementing and maintaining TESC throughout earthwork activities, and for working within accepted project limits to avoid unnecessary impacts to adjacent areas (especially critical areas).

5.12.3 Long-term Erosion Control and Maintenance

For long-term site care and management of critical area slopes:

- We recommend goals of low impact or vegetative enhancement be adopted for exterior areas outside building and road development zones, including preservation of existing trees and brush where possible. This will help minimize the chances of future instability on sloping areas following development. We advise planting of appropriate brushy vegetation among ancillary areas near structures and roads that are unavoidably disturbed during construction, either at the end of construction or in the future under final ownership.
- Removal of mature trees on steep grades should be limited to only those directly necessary to construct the project. If select trees are a concern for current or future hazard to structures or roads, a qualified arborist should be consulted to evaluate tree-limbing, topping or removal. Full removal actions should also be reviewed by a licensed geologist where in conflict with critical area slopes, and may require mitigative measures.

- Promoting future growth of strong-rooting brushy plants and new trees is encouraged both following construction and in the long term. Thick and healthy vegetation will assist in retaining cover soils, increase the hydrologic resistance of surface conditions, and lessen the risk of erosion that could result from incidental surface runoff or other overland drainage issues that could arise.
- Major landscaping alterations should be avoided on slopes outside of planned development areas unless properly reviewed by a geotechnical professional and found to be suitable for the location and surrounding conditions. We generally advise against placement of significant fills or terracing alterations on slopes, which could affect the downslope conditions or result in instability.
- If conditions are observed to evolve or deteriorate in the future and pose a potential concern for stability of the site or adjacent areas, we recommend conditions be re-observed at that time. Element Solutions should be contacted to reassess the site conditions, and can provide guidance for stabilization and best management practices at request of the property owner.

6 Closure

Thank you for the opportunity to contribute our expertise to your project. Please do not hesitate to contact us at (360) 671-9172 if you have any questions or comments regarding this report.

Sincerely,



Ryan Cooper, GIT
Project Scientist

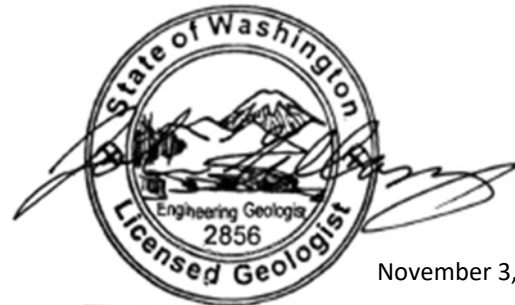

November 3, 2021

John R. Gillaspay

John Gillaspay, LEG
Environmental Services Manager



November 3, 2021

Lorne Balanko, PE
Senior Geotechnical Engineer

Statement of Limitations

This document has been prepared by Element Solutions for exclusive use and benefit of the Client. No other party is entitled to rely on any of the conclusions, data, opinions, or any other information contained herein. This document represents Element Solution's best professional judgment based on the information available at the time of its completion and as appropriate for the project scope of work. Services performed in developing the content of this document have been conducted in a manner consistent with that level and skill ordinarily exercised by members of the geologic engineering profession currently practicing under similar conditions. No warranty, expressed or implied, is made.

Exploration logs presented in this report represent locations and dates of field work. Conditions encountered by location may not be fully representative for other areas of the project site, and may vary depending on the timeframe of exploration. A degree of natural variation should be anticipated within native subsurface conditions; greater variation is likely where previously altered conditions or uncontrolled fills are found. If conditions are present in construction that are different than those encountered in this study, Element Solutions should be contacted to provide review and consultation, and to reevaluate our recommendations if necessary. We also recommend review of final plans and specifications by Element Solutions, as well as changes to the project scope that could impact the intent of our recommendations.

If the client elects to retain another geotechnical consultant for additional work or construction phase geotechnical support, the retained firm or individual is expected to review this report in full. They shall either verify and agree with the interpretations and recommendations provided, or offer their own recommendations. Element Solutions shall not be responsible for revised interpretations or recommendations made by others.

References

- 1) Lapen, T.J. Geologic Map of the Bellingham 1:100,000 Quadrangle, Washington. Washington State Department of Natural Resources, Division of Geology and Earth Resources Open File Report 2000-5, December 2000.
- 2) Natural Resources Conservation Service, Web Soil Survey, U.S. Department of Agriculture, <http://websoilsurvey.nrcs.usda.gov/app/WebSoilSurvey.aspx>, accessed online July, 2020.
- 3) Palmer, S.P., Magsino, S.L., Bilderback, E.L., Poelstra, J.L., Folger, D.S., and Niggemann, R.A. Liquefaction Susceptibility Map of Whatcom County, Washington. Washington State Department of Natural Resources, Division of Geology and Earth Resources Open File Report 2004-20, September 2000.
- 4) Wyllie, D. C., and Mah, C.W. Rock Slope Engineering – Civil & Mining. 4th Edition, 2005. Taylor & Francis e-Library publication.

Appendix I

- 1) Figure 1 – 1:24,000-Scale Site Vicinity Map, Jones-Edgemoor Property, Bellingham, WA
- 2) Figure 2 – Project Area & Lot Layout Overview Map, Jones-Edgemoor Property, Bellingham, WA
- 3) Figure 3a – Topographic LiDAR Map with Percent Slope Shading
Figure 3b – Project Lot Layout Map with Percent Slope Shading
- 4) Figure 4 – Project Overview LiDAR Map with Major LHA Features Annotated
- 5) Figure 5 – Detail LiDAR Map of Northeast Landslide Hazard Area and Buffer.

Appendix II

- 1) Figure 6 – Project Map with Test Pit Locations
- 2) Test Pit Logs, TP1 to TP26 – June 30 and July 1, 2020
- 3) Laboratory Testing Reports, GeoTest Services Inc., Project No. 20-0587. July 16, 2020
- 4) Laboratory Testing Report, Northwest Agricultural Consultants, Report No. 52022-1-1. July 21, 2020
- 5) Exhibit A – Field Photos of Exploration Conditions, June 30 and July 1, 2020
- 6) Figure 7 – Project Map with Measured Depths to Bedrock by TP Location
- 7) Figure 8 – Sea Pines Work Area Map with Test Pit & Hand Auger Locations
- 8) Exploration Logs – Sea Pines Area, TP1 to TP2, HA-1 to HA-2 – November 13, 2020
- 9) Exhibit B – Field Photos of Sea Pines Site Conditions & Explorations, November 13, 2020

Appendix III

- 1) Figure 9 – Project Overview LiDAR Map with Shading and Geologic Hazard Areas Annotated
- 2) Exhibit C – Field Photos of Geohazard Slope Features and Rock Exposures
- 3) Figure 10a – Stereonet of Bedrock Structures – Northwest Hill Cliff Face
Figure 10b – Stereonet of Bedrock Structures – West-Central Rock Outcrops



Pacific Surveying & Engineering

**GEOLOGIC FEASIBILITY INVESTIGATION
FOR THE
ANN JONES FAMILY REPRESENTATIVES
CHUCKANUT BAY PROPERTY**

DECEMBER 31, 2009

EXECUTIVE SUMMARY

The Ann Jones LP family representatives retained Pacific Surveying and Engineering to perform a reconnaissance-level geologic investigation of the subject property located at the north end of Chuckanut Bay to identify the feasibility of potential future development of the property. The investigation included collection and limited evaluation of existing information, meeting with the City of Bellingham Critical Areas Ordinance regulatory official, brief field inspection, and presentation of findings and recommendations in a summary report. In summary, the subject property contains areas with steep topography and development will have to consider site-specific engineering designs and mitigative measures for portions of the property.

In its current condition, the site infiltrates most of the precipitation it receives and there is little offsite movement of surface water. No evidence of surface water was observed in the west and central portion of the site, however minor surfacing of ground water via seeps was observed in the eastern portion of the site. It is hypothesized that groundwater migrates roughly perpendicular to the primary southward slope by moving laterally in the eastward direction along subsurface geologic structures. A time lapse created by the distance groundwater must travel before day-lighting likely attenuates peak discharges of surface water following high precipitation events, thus the observed seeps likely discharge at fairly uniform rates throughout the wet season. Surface water was only observed organizing into stream flow in two locations on site, one of which was modified by recent development off of Sea Pines Drive, the other occurred where groundwater was day-lighted by a recently uprooted tree. Future development of the site could impact the current hydrologic condition. Existing residential development located near the northeast corner of the subject property has likely increased the presence of surface water on site immediately downhill of those developments. Changes in hydrology can alter the probability, frequency and magnitude of mass wasting (landslide) activity.

Possible evidence of historic mass wasting (landslide) activity was also observed at the eastern portion of the property, whereas the steep slopes along the southeastern portion of the property did not show obvious signs of historic slope instability or movements with the exception of rock falls adjacent to cliff outcrops and minimal slope creep.

Following a development plan, additional and more detailed geotechnical evaluation for specific designs and locations will be needed. Geotechnical investigations will need to assess erosion, landslide potential, and seismic hazards and subsurface conditions. Future development may potentially impact slope stability and surface erosion.

Site Description

The study area is an amalgamation of several properties that are owned by various members of the Ann Jones family adjacent to Chuckanut Bay (Figure 1). The site is currently undeveloped and forested primarily with a wide variety of second growth timber, shrubs and herbaceous plant species, but Douglas Fir, Big Leaf Maple, Red Alder and Western Red Cedar dominate the tree canopy. Air photos indicate that the most of the site was logged in the late 1960's to mid-1970's. It is possible that a quarry existed east of the topographic high point of the property but this was not verified. No other historic uses of the property are known, however pre-historic uses by native peoples have been documented. Residential development adjacent to the project site has occurred over the past century, significantly so in the past two decades.

The site is located on a landform consisting of Paleocene aged Chuckanut Formation (TKc) bedrock outcrops that have been folded, uplifted and eroded (Easterbrook, 1976; Figures 2 & 3). Chuckanut Formation geology consists of sandstone, conglomerate, shales, and locally sub-bituminous coals. Pleistocene glacial advances impacted the project area by causing erosion and mantling portions of the site with sediment. Holocene activity at the site has been dominated by development of soils, while erosion and mass wasting at the site are interpreted to be minor. Soils present at the site include: Chuckanut loam (Unit 26), Everett-Urban land complex (Unit 52), and Nati loam (Unit 110) (NRCS 2009, Figure 4).

The site has considerable variations in topography and includes flat, low to moderate sloping terrain, steep terrain and cliffs (Figure 5). The site topography has been locally altered or modified by historic road building, timber harvest activities, and adjacent residential development (primarily unconsolidated fill and debris piling). The majority of the site drains to Chuckanut Bay, however the northwest portion of the site drains toward Bellingham Bay.

Geologic Hazards Defined

Landslide Hazard

Landslide hazard areas are defined by the Washington Administrative Code (WAC) and the City of Bellingham Critical Areas Ordinance (CAO) as those areas potentially subject to risk of mass movement due to a combination of geologic, topographic, and hydrologic factors. Specific landslide designations relevant to the subject site, as defined by the WAC and CAO, include:

1. Areas with all three of the following characteristics:
 - Slopes steeper than 15 percent; and

- Hillside intersecting geologic contacts with a relatively permeable sediment overlying a relatively impermeable sediment or bedrock; and
 - Springs or ground water seepage.
2. Any area with a slope of forty percent or steeper and with a vertical relief of ten or more feet except areas composed of consolidated rock
 3. Slopes parallel or subparallel to planes of weakness in subsurface materials
 4. Areas depicted as landslide hazards by the City folio maps. Portions of the site have been identified as having High Landslide Potential (Fox et al, 1991) in that they have slopes greater than 30%, slopes exceeding 80%, and slopes greater than 15% that may be potentially unstable because of other factors (Figure 6).

The characteristics and frequency of landslides are dependent on several variables, including soil type, permeability and depth, slope, groundwater conditions, seismic occurrence, disturbances, and other factors. Several categories of landslides are possible at the subject site. These include: slides (rotational and translational), flows (debris flow, earth flow, mud flow, rock flow), falls and topples (Varnes, 1978)

Common in the Pacific Northwest on steep slopes are episodic earth slides (shallow-rapid slides) where a precipitation event is the dominant trigger mechanism. Typically, shallow-rapid mass wasting events occur within the weathered soils or colluvial sediment that overlies relatively low-permeability soils or bedrock. In certain conditions, dense glacial sediments can experience mass wasting such as earth flows or earth slumps on steeper slopes and the potential for these types of events is exacerbated by groundwater. Soil creep is also common on steep slopes.

Bedrock stability is based on bedding and jointing within the rock. Chuckanut Formation sandstone can weather very quickly to soil or can be interbedded with less competent rock (e.g. shales) and is also commonly jointed and therefore susceptible to rock fall and topples.

Erosion Hazard

Erosion hazard areas are defined by the CAO as those areas containing soils which, according to the United States Department of Agriculture Soil Conservation Service Soil Classification System, may experience severe to very severe erosion. Erosion hazard potential can be increased during the clearing and earthwork phase of construction when disturbed soils are exposed to weather, disturbance and traffic.

The National Resources Conservation Service Soil Survey of Whatcom County soils map indicates that the site soils have a low to high hazard of water erosion, but have moderate to severe erosion hazard during excavations. Soils with higher percentages of fines have a higher susceptibility to erosion in the disturbed state, particularly on steeper slopes.

Seismic Hazard

Seismic hazard areas are defined by the CAO as those areas subject to severe risk of damage as a result of earthquake induced ground shaking, slope failure, settlement, or soil liquefaction. Seismic induced slope failure and rock fall are possible at the site. Settlement and liquefaction risks are likely low.

The Puget Sound region is seismically active as documented by the Pacific Region Seismic Network. Several significant earthquakes have been historically experienced in the project vicinity, including the 1872 North Cascades event and the 1906 Rosario Strait event. Recent discovery of Holocene fault surface ruptures near Kendall and Glacier also demonstrate the presence of significant seismic events. There are no known faults mapped at the site.

Field Observations

The reconnaissance-level field investigation occurred on December 4th, 2009 and was conducted by Paul Pittman of PSE who was accompanied by Elizabeth Binney of Pacific Ecological Consultants. The fieldwork included traverses of portions of the project area to observe geology, topography, geomorphology, surface water expressions, and evidence of erosion and mass wasting.

The site was observed to consist of ridge or cliff forming units of Chuckanut Formation Sandstone, locally overlain with glacial deposits that included numerous granitic erratics and was very dense and compact and interpreted to be till. Locally thick soil horizons (approximately 1-foot) were also encountered at several locations at the site where low gradient topography or topographic swales between parallel bedrock outcrops occurred. Field observations suggest that the soils on the project site have a relatively low susceptibility to erosion in an undisturbed state because of dense vegetation, but that alteration of these conditions could significantly increase the erosion potential.

Areas of slopes greater than 40 percent were observed on site. Much of the southern portion of the property and other local areas qualifies as having potential landslide hazard (Figure 5). In addition to steep topography, several vertical or near vertical bedrock cliffs were observed across the site. The bedding of the Chuckanut Formation dips approximately 40 degrees toward the north. Where the slopes face southerly, this means that the bedding dips into the slope. Where the

slopes face northerly (the ridge crest in the northwest portion of the site), dip slopes may occur, however none were observed exposed due to soil formation or glacial sediment mantling. Jointing of the Chuckanut Formation is common and evidence of topples and falls were observed at many of the cliff forming outcrops. No evidence of massive rotational or translational slope stability failures were observed during the field reconnaissance with the exception of a possible earth slump located at the eastern property margin (Figure 7). The interpretation of a possible earth slump is supported by the topographic expression (steep, arcuate scarps above a hummocky bench flanked by abrupt lateral topographic ridges perpendicular to bedrock ridges) and the presence of numerous seeps in converging topography. Additional analysis would be needed to confirm this hypothesis.

No historic evidence of mass wasting at the site were observed in the photo record (1963, 1975, 1988, 1997, 1998, 2002, 2004, and 2008). In summary, the steep slopes of the site appeared to exhibit historic stability, with the exception of rock fall/topple, and even evidence of soil creep was minimal.

Development on or above steep slopes could impact slope stability by changing surface or groundwater flow on the slopes. In addition, risk of landslides could be impacted by construction near or on steep slopes because of grading disturbance or additional load application from structures such as buildings, road fill embankments, topographic alterations or retaining walls.

In its current condition, the site infiltrates most of the precipitation it receives and there is little offsite movement of surface water. No evidence of surface water was observed in the west and central portion of the site, however minor surfacing of ground water via seeps was observed in the eastern portion of the site (Figure 7). It is hypothesized that groundwater migrates roughly perpendicular to the primary southward slope by moving laterally in the eastward direction by following subsurface geologic structures. A time lapse created by the distance groundwater must travel before day-lighting likely attenuates peak discharges of surface water following high precipitation events, thus the observed seeps likely discharge at fairly uniform rates throughout the wet season. Surface water was only observed organizing into stream flow in two locations on site, one of which was modified by recent development off of Sea Pines Drive, the other occurred where groundwater was day-lighted by a recently uprooted tree. Existing residential development located near the northeast corner of the subject property has likely increased the presence of surface water on site immediately downhill of those developments and a survey conducted by Leonard, Boudinot & Skodje (LBS, 2004) showed a drain from an adjacent property owner discharging water on site. This drain, and at least one other were observed at the northeast corner of the site. Additionally, numerous trees in the area where seeps and possible slope instability were observed have been cut down. The removal of these trees can negatively impact both the hydrology and slope stability at that location.

Currently the site is well vegetated and the potential for erosion is low since most water arriving to the ground is infiltrated. However, the soil has significant fines such that it is considered susceptible to erosion when disturbed on slopes. A total of eight Test Plots across the site were collected and documented by Elizabeth Binney on December 4th and her assessments will be included within her wetland report. Grading (cuts into native soil, and placement of fill soils with slope geometries) increases the potential for erosion exists during construction and until the site has healed. Additionally, interception, changes in soil permeability (compaction) or development that interrupts or causes the surfacing of groundwater can alter the site hydrology that may increase erosion and landslide hazard potential.

Conclusions

In summary, geologic hazards at the site exist and include landslide, erosion and seismic hazards. Development of the property will likely include regulations imposed by the City of Bellingham's Critical Areas Ordinance. It is noted that those regulations are scheduled for an update in 2012. Depending upon the scale of the development, a SEPA checklist may also need to be submitted. It is also noted that the Shorelines Jurisdiction extends 200 feet horizontally landward from the line of Mean Higher High Water (MHHW).

Some types of development could impact the site hydrology and thus affect the landslide and erosion hazard potential. Because of the step slopes and existing groundwater conditions, modifications of groundwater or surface water flow may impact the potential size and frequency of mass wasting events. The fine-grained soils found on site are susceptible to soil erosion resulting from the movement of heavy equipment or site grading. As these plans are developed, the geologic hazards will need to be assessed in light of the proposed changes. For planning level conceptualizations, design considerations should include managing surface and ground water changes and impacts, steep topography and cliffs, excavation of bedrock, over excavation of soils, and construction/disturbance related erosion.

There are portions of the site where development may be technically possible, but the engineering, mitigation and assessment needs will dramatically increase the investment for that development. These areas likely include slopes steeper than 40%, cliffs, areas where seepage or possible landslides exist, and areas within the Shorelines Jurisdiction. Any future significant development proposal will likely trigger requirement of a full geotechnical assessment as evidenced by similar sites and projects in this vicinity.

Recommendations

Once a design concept or plan is formalized for the site, we recommend the following additional geotechnical information be collected:

- extensive review of geotechnical assessments for areas adjacent to the proposed project site;
- exploration and detailed mapping of surfaces, outcrops, and slopes in area of proposed development(s);
- subsurface exploration and characterization in proposed roadway/utility corridors; and
- slope or hazard setback staking.

This report was submitted by:

Pacific Surveying and Engineering

Paul D. Pittman, L.E.G.
Environmental Services Manager

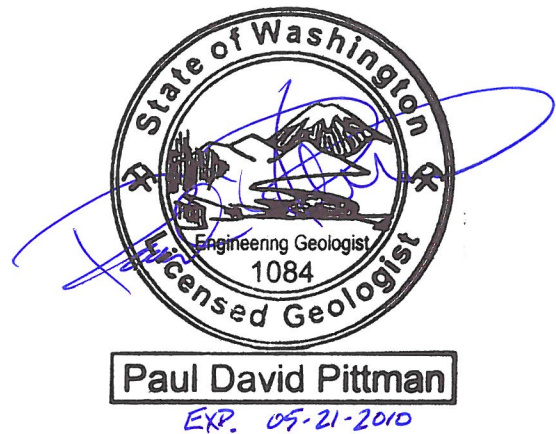

Statement of Limitations

This document has been prepared by Pacific Surveying and Engineering Services, Inc. (PSE) for the exclusive use and benefit of the Ann Jones and her family representatives. No other party is entitled to rely on any of the conclusions, data, opinions, or any other information contained in this document.

This document represents PSE's best professional judgment based on the information available at the time of its completion and as appropriate for the project scope of work. Services performed in developing the content of this document have been conducted in a manner consistent with that level and skill ordinarily exercised by members of the geologic engineering profession currently practicing under similar conditions. No warranty, expressed or implied, is made.

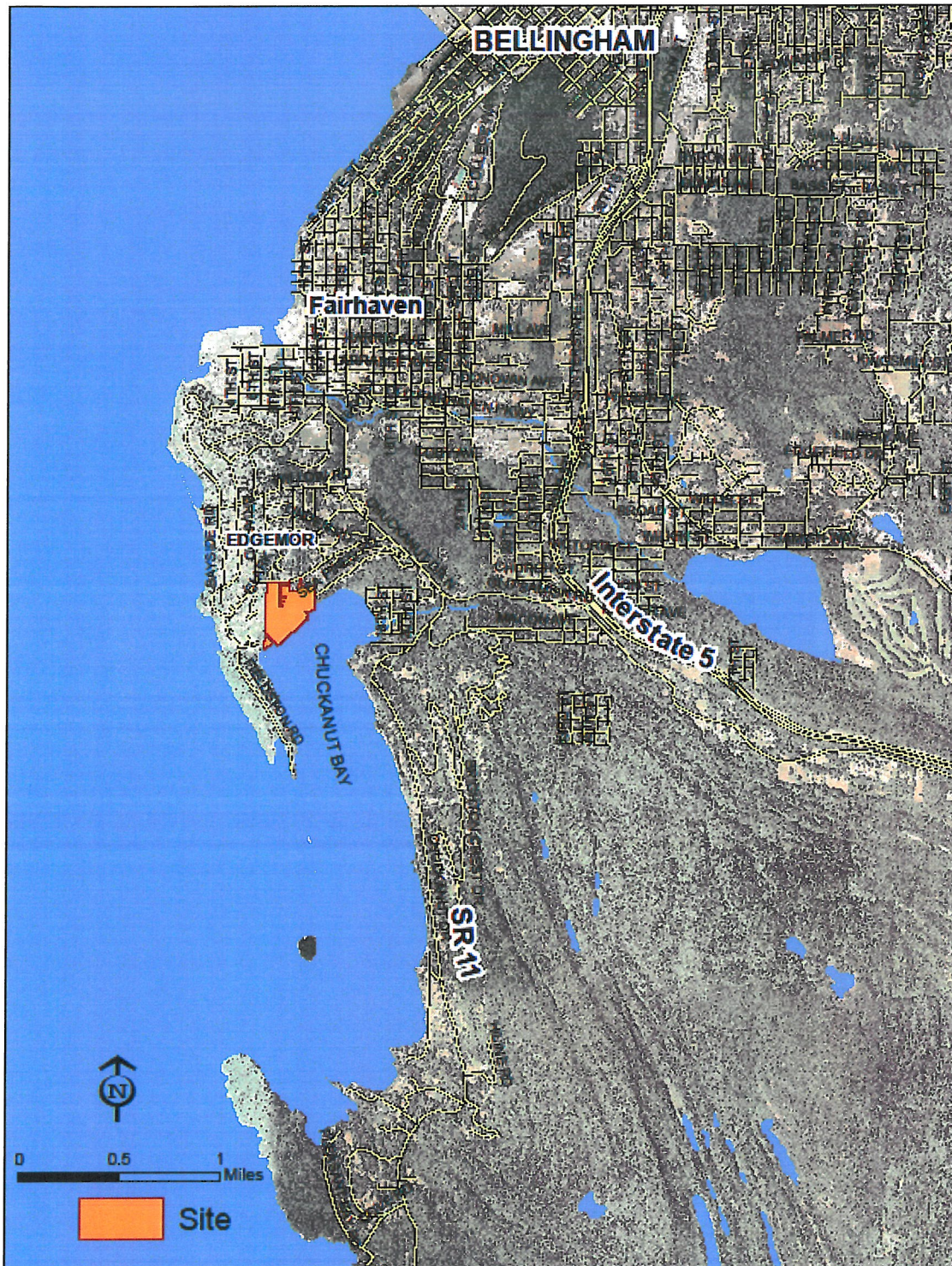

FIGURE 1: Vicinity map



FIGURE 2: The geology of the site is mapped as Chuckanut Formation (TKc) (Easterbrook 1976). Numerous outcrops of sandstone were at the site. The more resistant and massive beds often form substantial cliffs throughout the site. Bedding strike was roughly N80E (260 degrees) and dipped to the north at approximately 40 degrees. The site is located near or within the hinge of a large anticline that plunges to the northwest (See Figure 3).

The site was also affected by Pleistocene glaciations and deposits of till and drift mantle much of the site. Thickness of the glacial deposits appear to vary from several inches to possibly several feet. Holocene soils were observed to have developed and can be quite thick (over 1.5 feet observed) locally, especially in the swales occurring between resistant bedrock ridges.

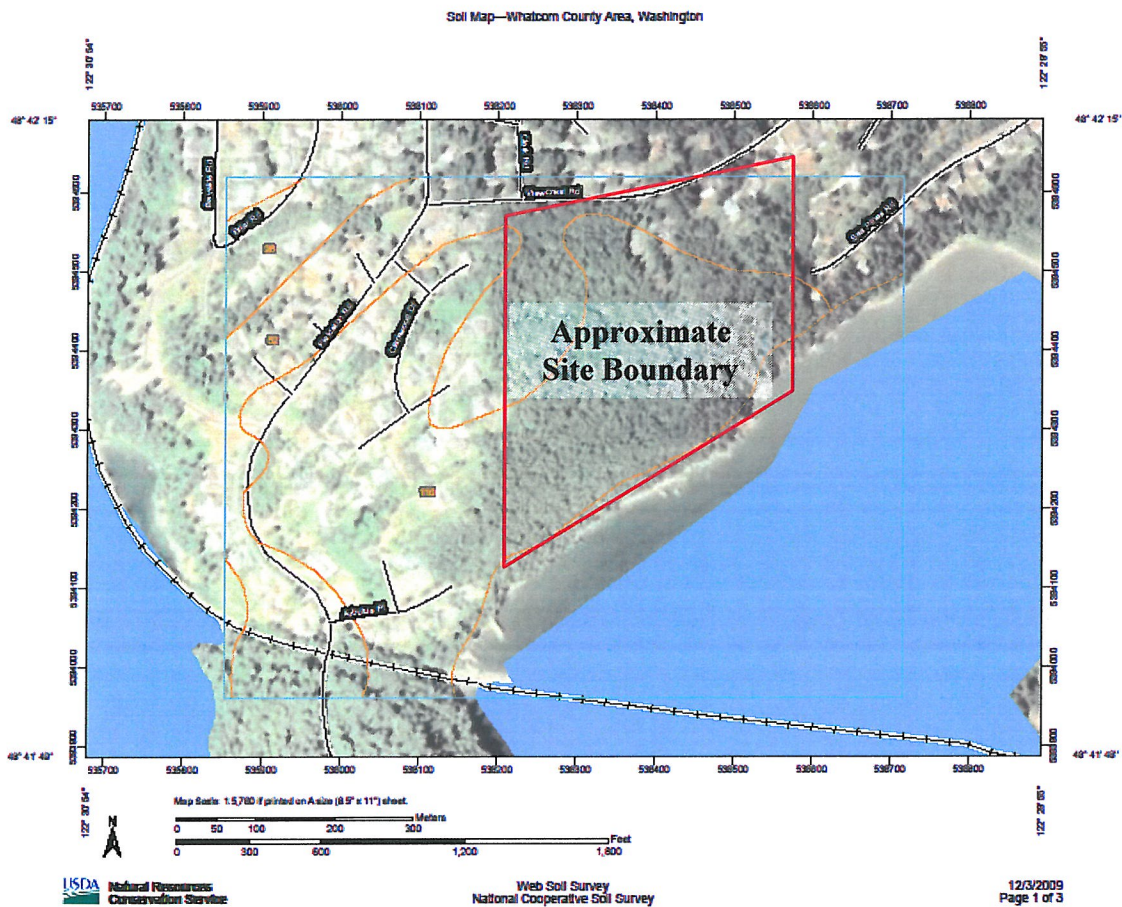

FIGURE 4: Natural Resources Conservation Services Soil Map Study (from Web Soil Survey, Version 6, Sep 22, 2009). Units present at the site include Nati Loam (Unit 110), Chuckanut Loam (Unit 26), and Everett-Urban Land Complex (Unit 52).

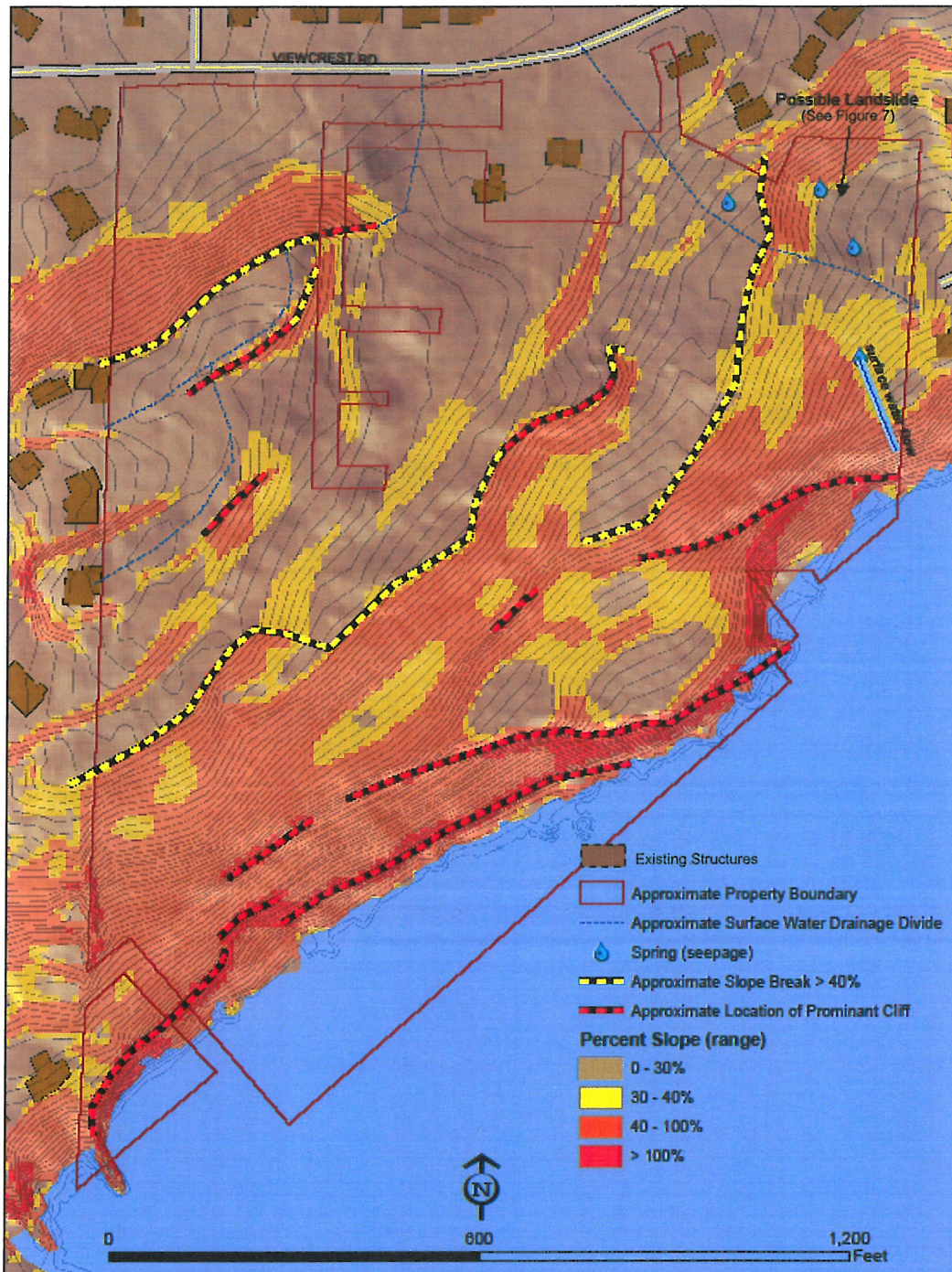

FIGURE 5: Slope assessment. Contours (5-foot interval) and Percent-Slope raster were generated from 2004 photogrammetry (City of Bellingham). The reconnaissance-level field investigation was conducted December 4th, 2009. The reference to the possible landslide is discussed in the Figure 7.

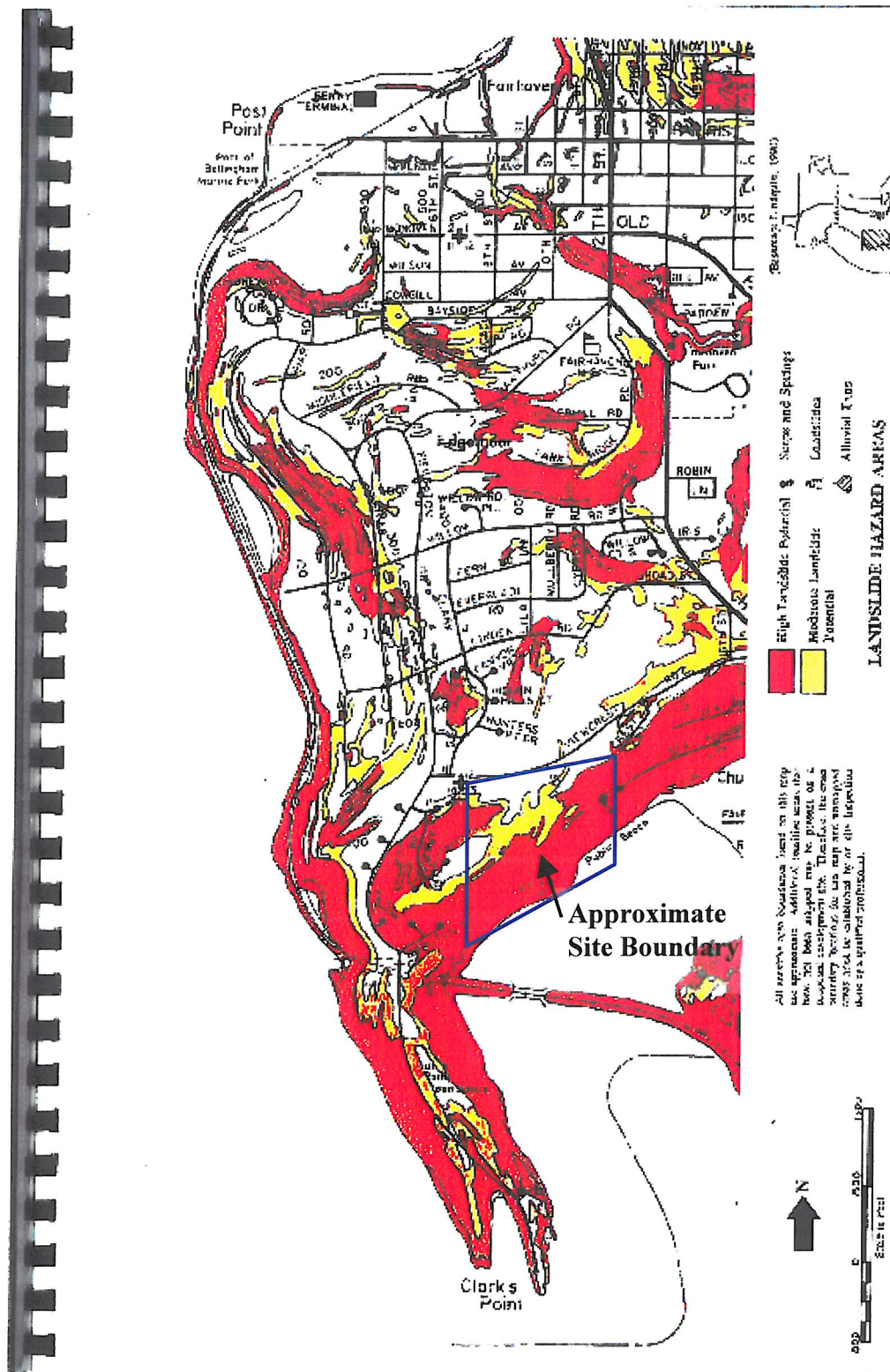

FIGURE 6: Fox et al 1991 "Geologic Hazards Area; Map Folio"

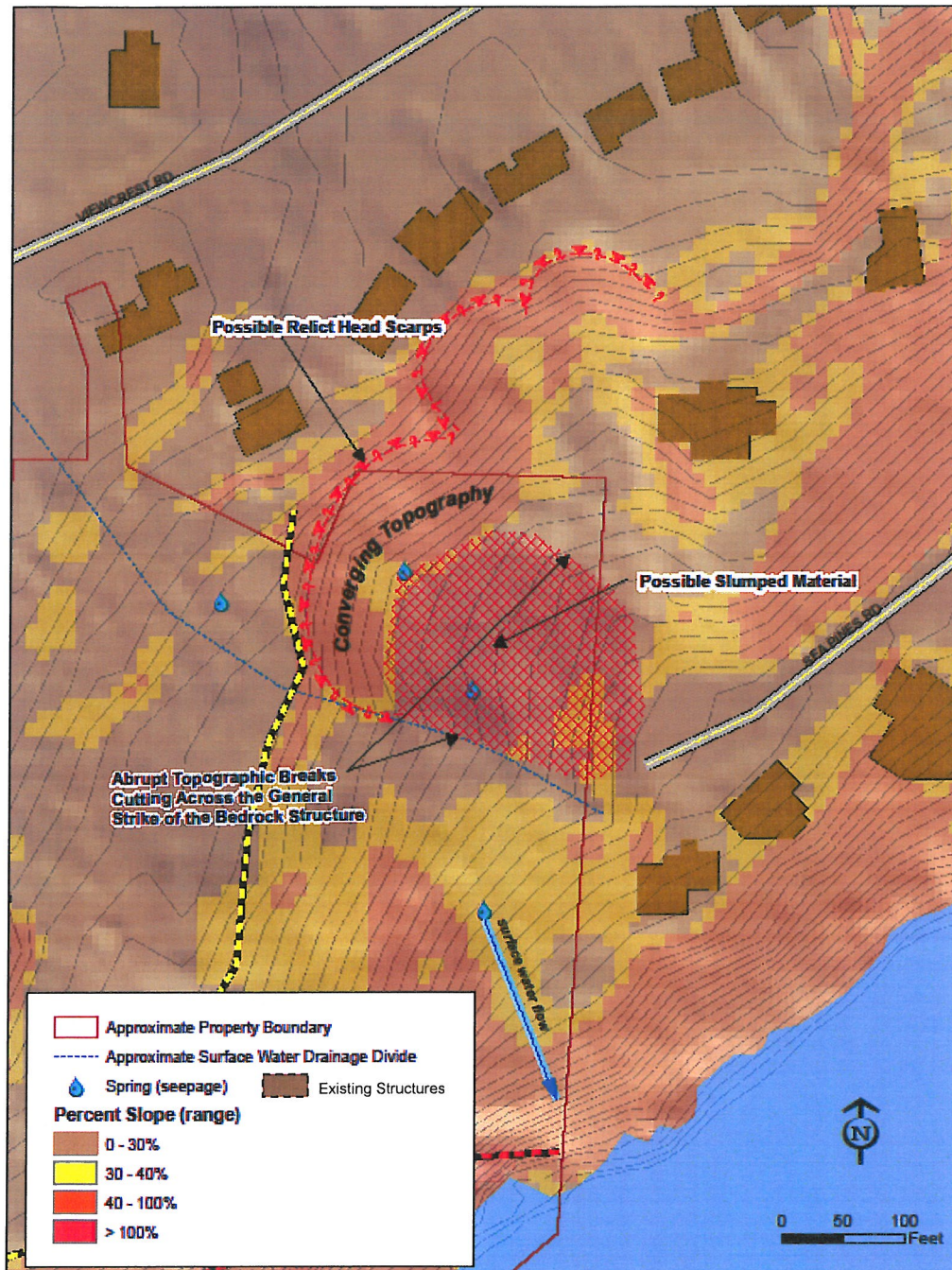

FIGURE 7: Geomorphology and field indicators suggest that this might be a relict earth-flow or slump-type landslide. Additional studies are recommended for this location if development was proposed on or adjacent to this landform.

PHOTOS: By P. Pittman taken December 4th, 2009



Photo looking uphill at a Chuckanut Formation sandstone bedrock outcrop creating a vertical cliff face approximately 10 feet in height.



Photo of a bedrock cliff showing evidence of "toppling" of blocks that failed along jointing planes. The blocks did not travel beyond 20 feet down-slope from the outcrop from which they originated.



Photo showing a location in which minor soil creep was observed on slopes nearing 100%. In general, the site exhibited few locations with evidence of soil creep. The location of this photo is just above the beach 300 feet southwest of the southeast property corner.



Photo documenting the source of seepage that developed into stream flow for a distance of approximately 160 feet before being infiltrated. This water source did not reach the beach as surface water. The seepage started in a shallow depression created by tip up of an approximately 24-inch diameter Western Red Cedar.

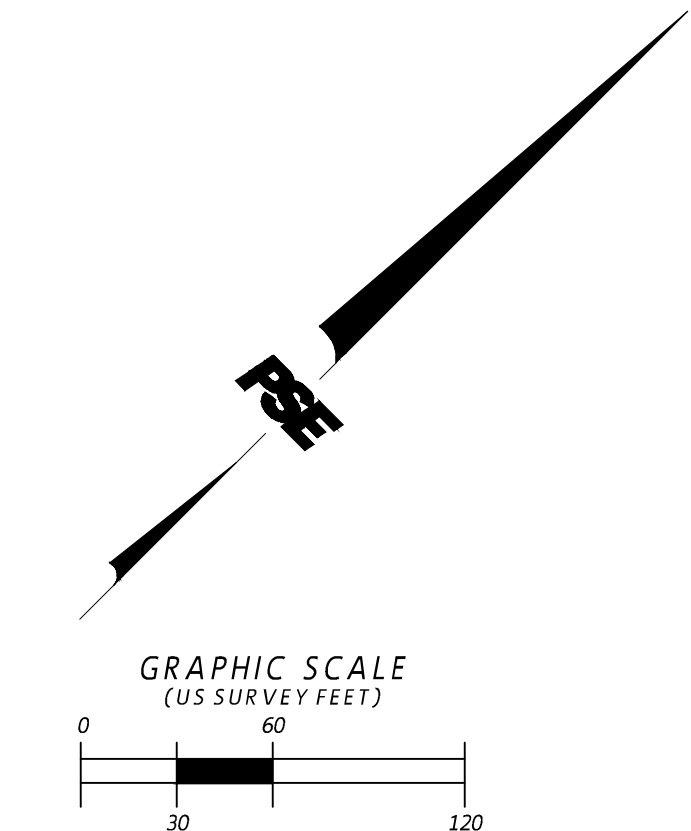

Photo looking down-slope across the topographic "bench" occurring below a steep "arcuate" topographic feature. Seepage was abundant in this location and the site was inhabited with small diameter alder, horsetail, and blackberry. This landform may be a slump or earthflow feature. Felling of trees occurred at this site likely in the past year or two.



Photo looking up the steeper arcuate topography that may be a scarp formed from downward movement of the mass shown in the previous image (See Figure 7).

8.4 BASIN MAP



TDA 1

- TOTAL AREA = 307,109 SF/7.04 AC
- MUNICIPAL WATERSHED: BELLINGHAM BAY
- TDA OUTFALL: VIEWCREST RD STORM SEWERS

TDA 3

- TOTAL AREA = 63,742 SF/1.46 AC
- MUNICIPAL WATERSHED: BELLINGHAM BAY
- TDA OUTFALL: S CLARKWOOD DR STORM SEWERS

TDA 2

- TOTAL AREA = 768,668 SF/17.61 AC
- MUNICIPAL WATERSHED: BELLINGHAM BAY
- TDA OUTFALL: CHUCKANUT BAY

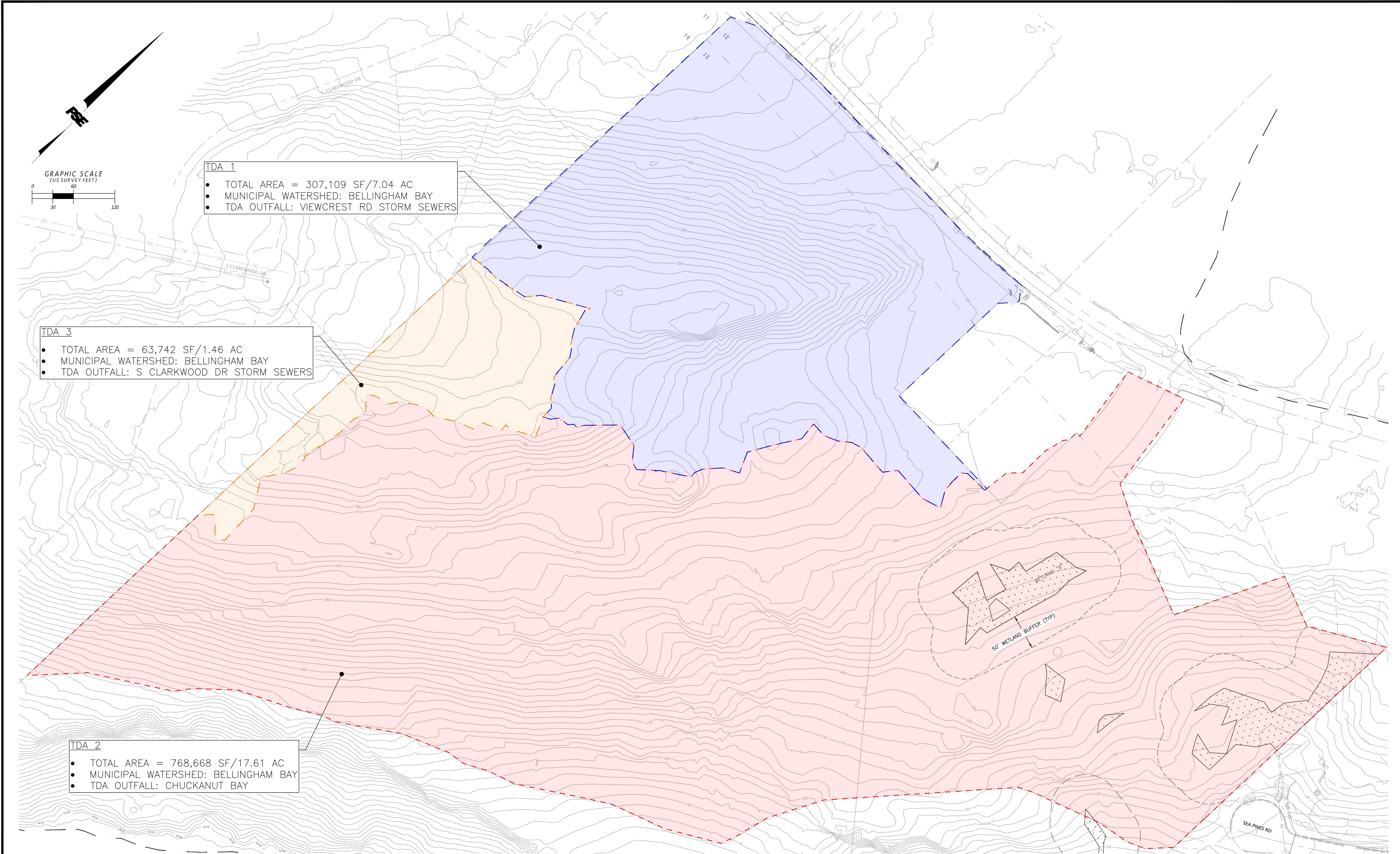

CALL BEFORE YOU DIG 1-800-424-5555

REVISION	DATE	DESCRIPTION	ISSUE	DATE	DESCRIPTION
			1	9/13/2021	PRELIMINARY SITE PLAN
			2	10/18/2022	COB RFI REVISIONS
			3	6/09/2023	COB RFI 2 REVISIONS
			4	12/01/2023	COB RFI 3 REVISIONS

ANN C. JONES FAMILY LP
 807 CHUCKANUT SHORE ROAD
 BELLINGHAM, WA 98229

THE WOODS AT VIEWCREST
 ESTATE PLANNING
 SITE IMPROVEMENTS
PRE-DEVELOPMENT WATERSHED MAP

PSE PACIFIC SURVEYING & ENGINEERING, INC.
 909 Squakum Way, Suite 111 | BELLINGHAM, WA 98225
 T: 360.671.7387 | F: 360.671.4685
 WWW.PSESURVEY.COM | INFO@PSESURVEY.COM

DATA	DRAWN BY	CHECKED BY	FIELD BOOKS
BASE	--	--	DESIGN: --
DESIGN	RIR	JVY	STAKING: --
XREF:	--	--	ASBUILT: --
JOB#:	2019196	--	DATUM
HORIZ. SCALE:	SEE GRAPHIC SCALE	HORIZ.:	NAD83
VERT. SCALE:	AS NOTED	VERT.:	NAV089
DWG:	P:\Pse Project\2019196\DWGs\1_SHEET\2019196_ecp_SP.dwg		
SHEET 01 OF 02			



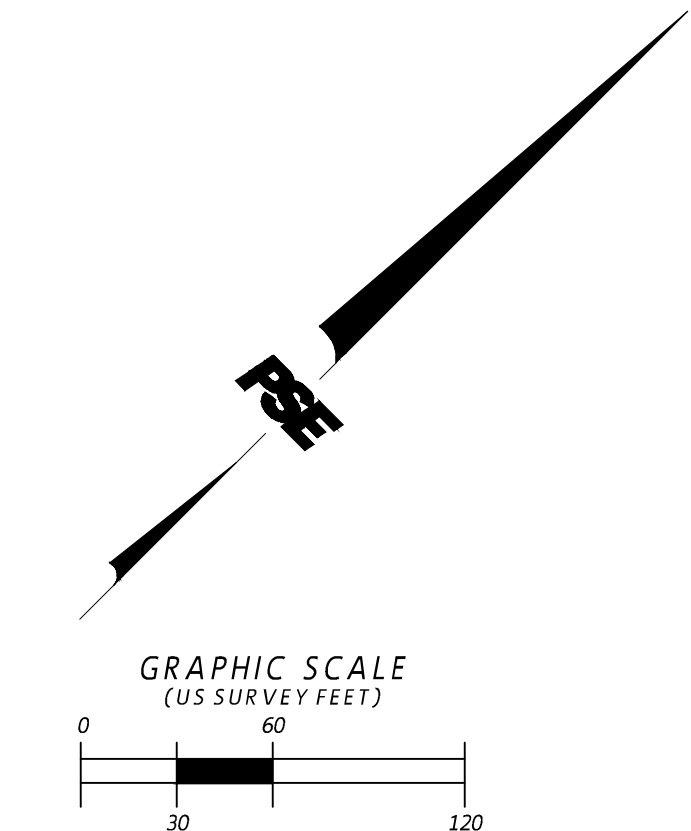

TDA 1

- TOTAL AREA = 170020 SF/3.90 AC
- IMPERVIOUS SURFACE AREA = 37,663 SF
- WATER QUALITY TREATMENT: MODULAR WETLAND
- TDA OUTFALL: VIEWCREST RD STORM SEWERS

TDA 3

- TOTAL AREA = 23,671 SF/1.46 AC
- PROPOSED IMPERVIOUS SURFACE = 2,100 SF
- TDA OUTFALL: S. CLARKSON DR STORM SEWERS

TDA 2

- TOTAL AREA = 943,008 SF/21.60 AC
- IMPERVIOUS SURFACE AREA = 181,118 SF
- WATER QUALITY TREATMENT: MODULAR WETLAND
- TDA OUTFALL: SEA PINES STORM SEWER, CHUCKANUT BAY

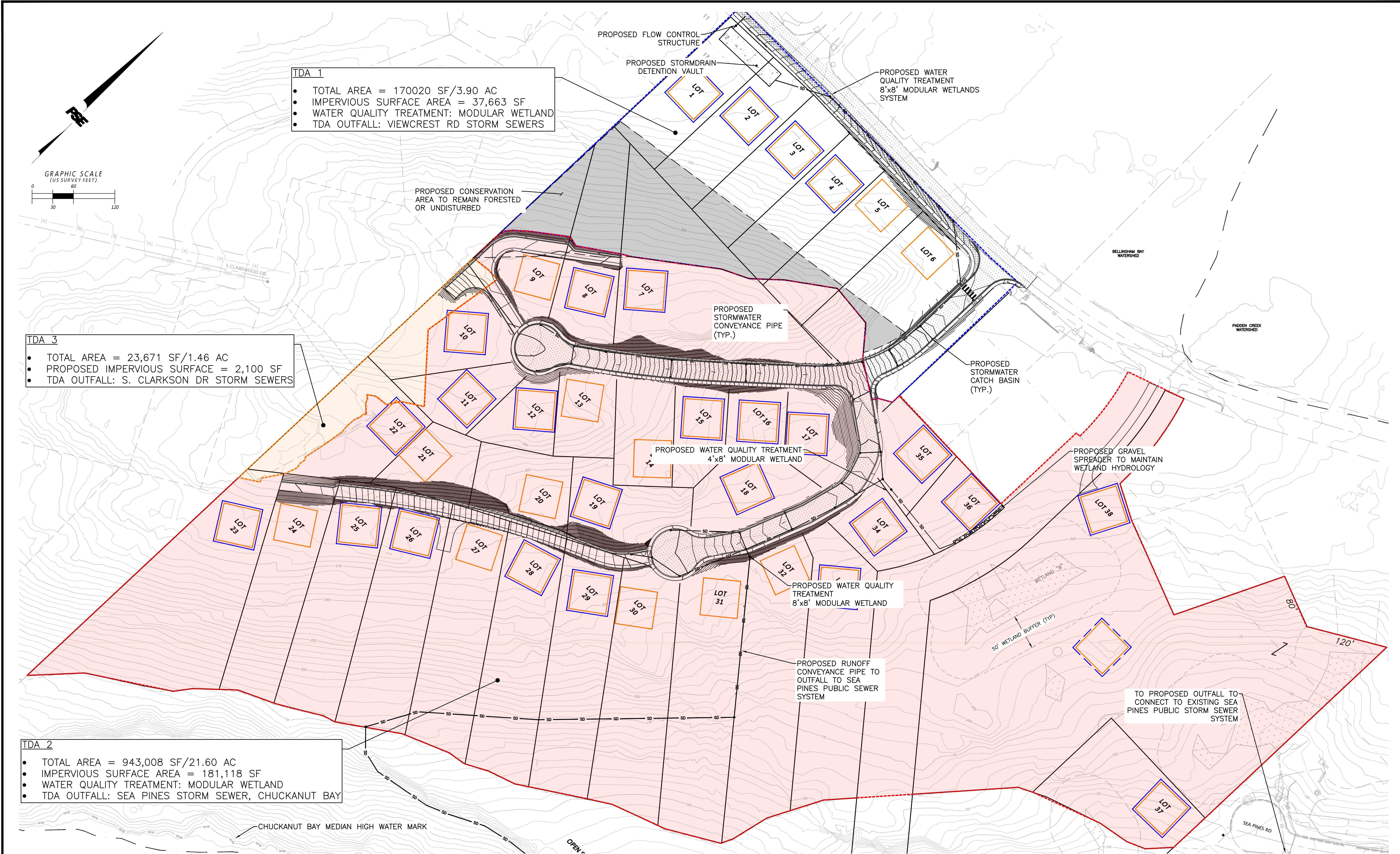

CALL BEFORE YOU DIG 1-800-424-5555

REVISION	DATE	DESCRIPTION	ISSUE	DATE	DESCRIPTION
			1	9/13/2021	PRELIMINARY SITE PLAN
			2	10/18/2022	COB RFI REVISIONS
			3	6/09/2023	COB RFI 2 REVISIONS
			4	12/01/2023	COB RFI 3 REVISIONS

ANN C. JONES FAMILY LP
 807 CHUCKANUT SHORE ROAD
 BELLINGHAM, WA 98229

THE WOODS AT VIEWCREST
 ESTATE PLANNING
 SITE IMPROVEMENTS
POST-DEVELOPED WATERSHED MAP

PSE
PACIFIC SURVEYING & ENGINEERING, INC.
 909 Squakum Way, Suite 111 | BELLINGHAM, WA 98225
 T: 360.671.7387 | F: 360.671.4685
 WWW.PSESURVEY.COM | INFO@PSESURVEY.COM

DATA	DRAWN BY	CHECKED BY	FIELD BOOKS
BASE			DESIGN: -
DESIGN	RIR	JVY	STAKING: -
XREF:			ASBUILT: -
JOB#:	2019196		DATUM: -
HORIZ. SCALE: SEE GRAPHIC SCALE			NAD83
VERT. SCALE: AS NOTED			NAV089
DWG: P:\Pse Project\2019196\DWGs\1_SHEET\2019196_ecP_SP.dwg			
		SHEET	02 OF 02



8.5 DRAWINGS

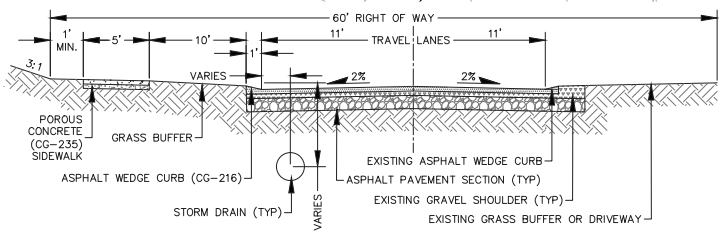
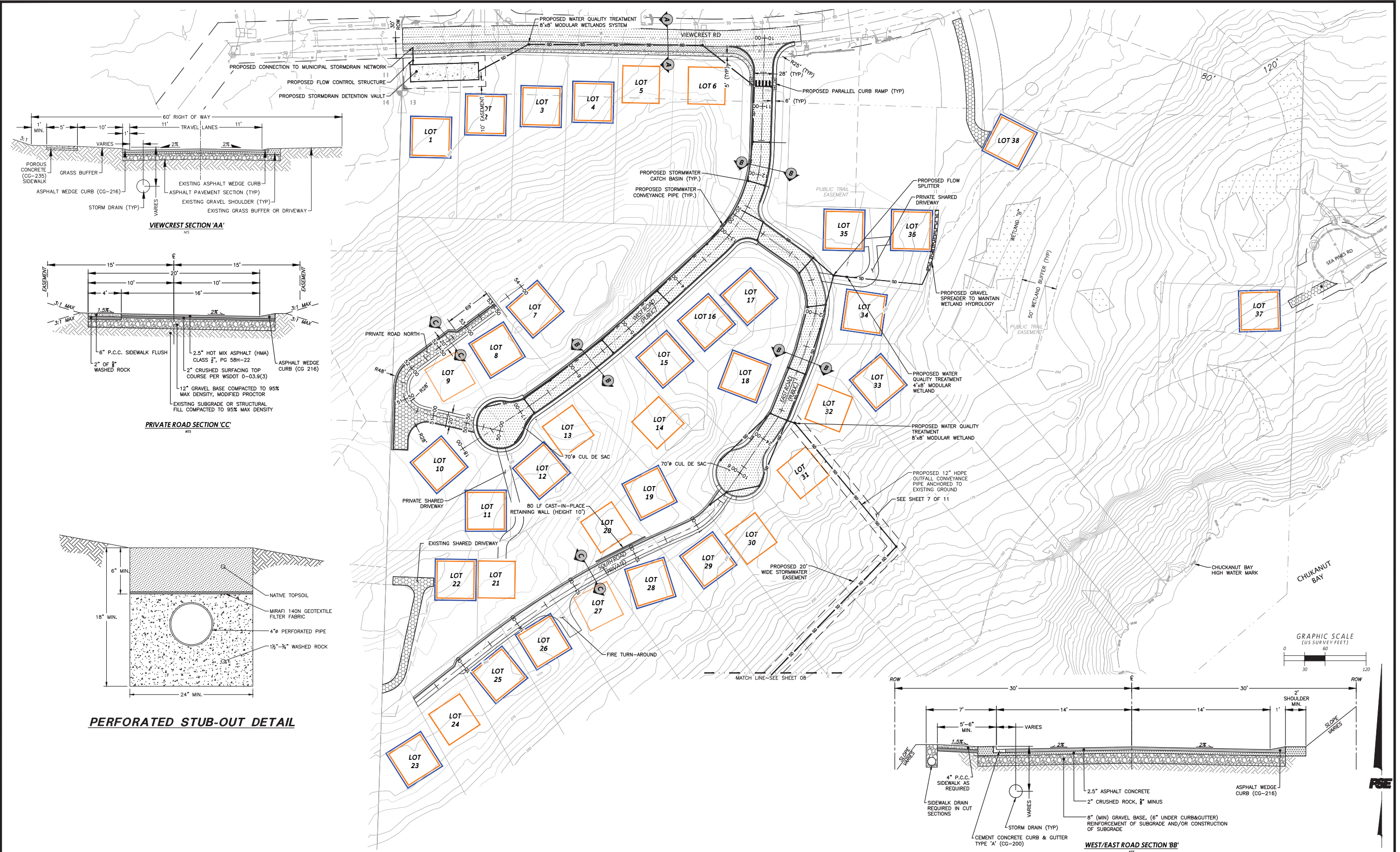

VIEWCREST SECTION AA'

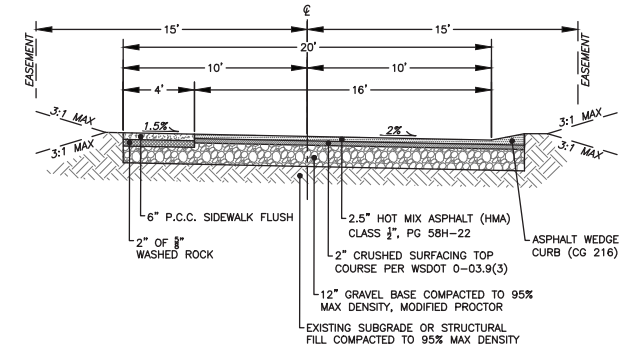

PRIVATE ROAD SECTION CC'

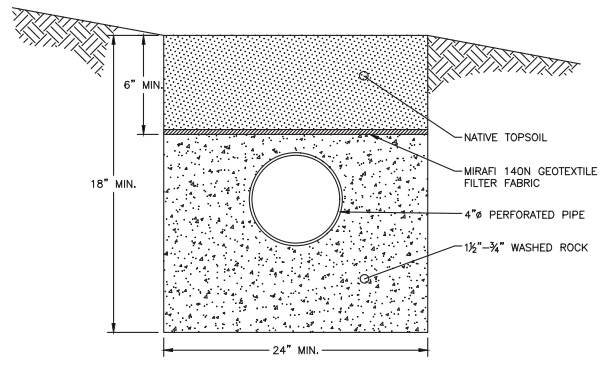

PERFORATED STUB-OUT DETAIL

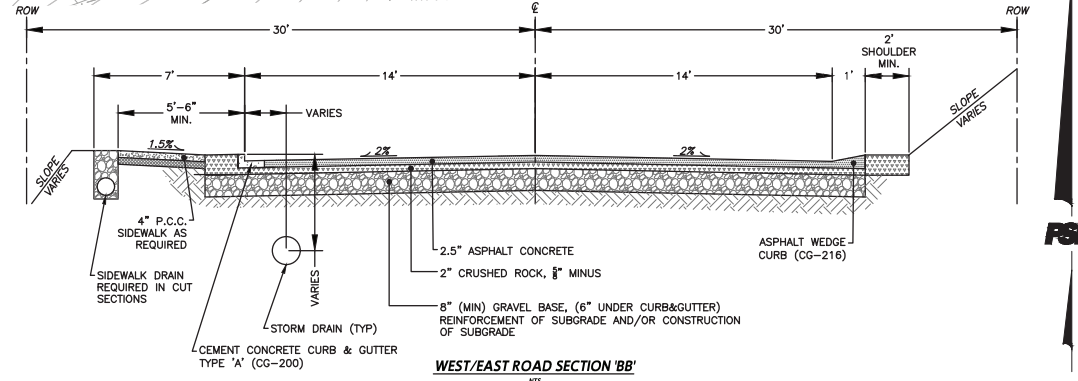

WEST/EAST ROAD SECTION BB'

REVISION	DATE	DESCRIPTION	ISSUE	DATE	DESCRIPTION
1	9/13/2021	PRELIMINARY SITE PLAN			
2	10/18/2022	COB RFI REVISIONS			
3	6/09/2023	COB RFI 2 REVISIONS			
4	12/01/2023	COB RFI 3 REVISIONS			

ANN C. JONES FAMILY LP
 807 CHUCKANUT SHORE ROAD
 BELLINGHAM, WA 98229

THE WOODS AT VIEWCREST
 ESTATE PLANNING
 SITE IMPROVEMENTS
ROAD & STORMDRAIN PLAN

PACIFIC SURVEYING & ENGINEERING, INC.
 909 Squallum Way, Suite 111 | BELLINGHAM, WA 98225
 T: 360.671.7387 | F: 360.671.4685
 WWW.PSESURVEY.COM | INFO@PSESURVEY.COM

DATA	DRAWN BY	CHECKED BY	FIELD BOOKS
BASE	-	-	DESIGN: -
DESIGN	RJR	JVY	STAKING: -
ASBUILT	-	-	ASBUILT: -
JOB#:	2019196		DATUM
HORIZ. SCALE:	SEE GRAPHIC SCALE		HORIZ.: NAD83
VERT. SCALE:	AS NOTED		VERT.: NAVD88
DWG:	P:\Pac Project\2019196\DWGs\SHEET\2019196_ocP_SP.dwg		



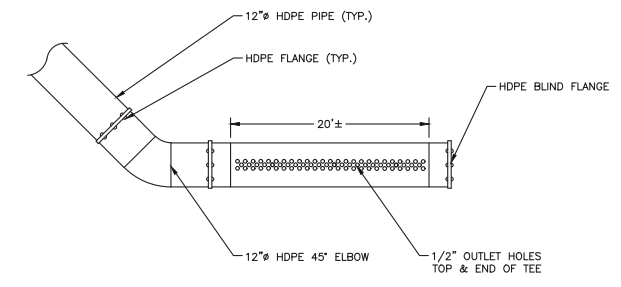
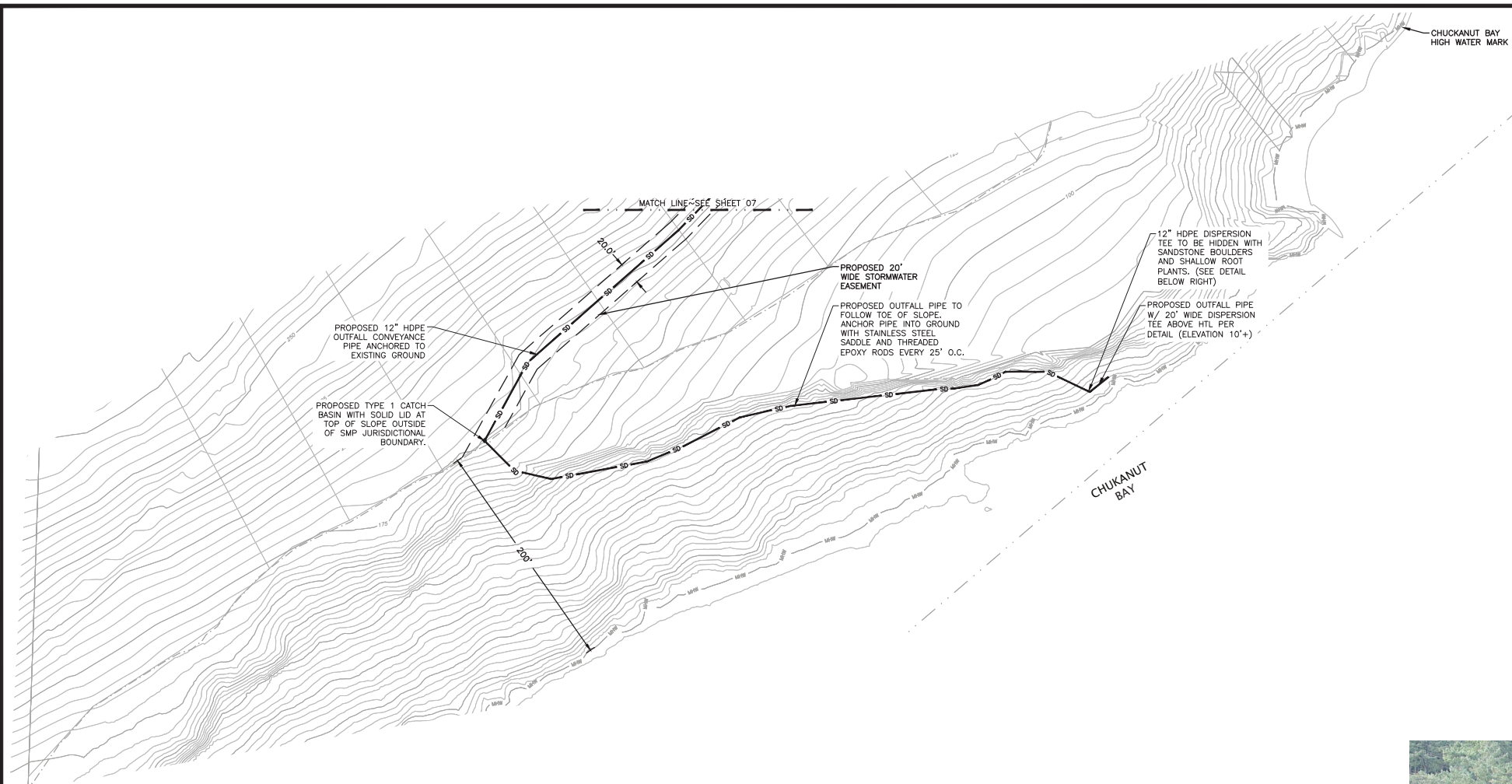

FLOW DISPERSION TEE DETAIL

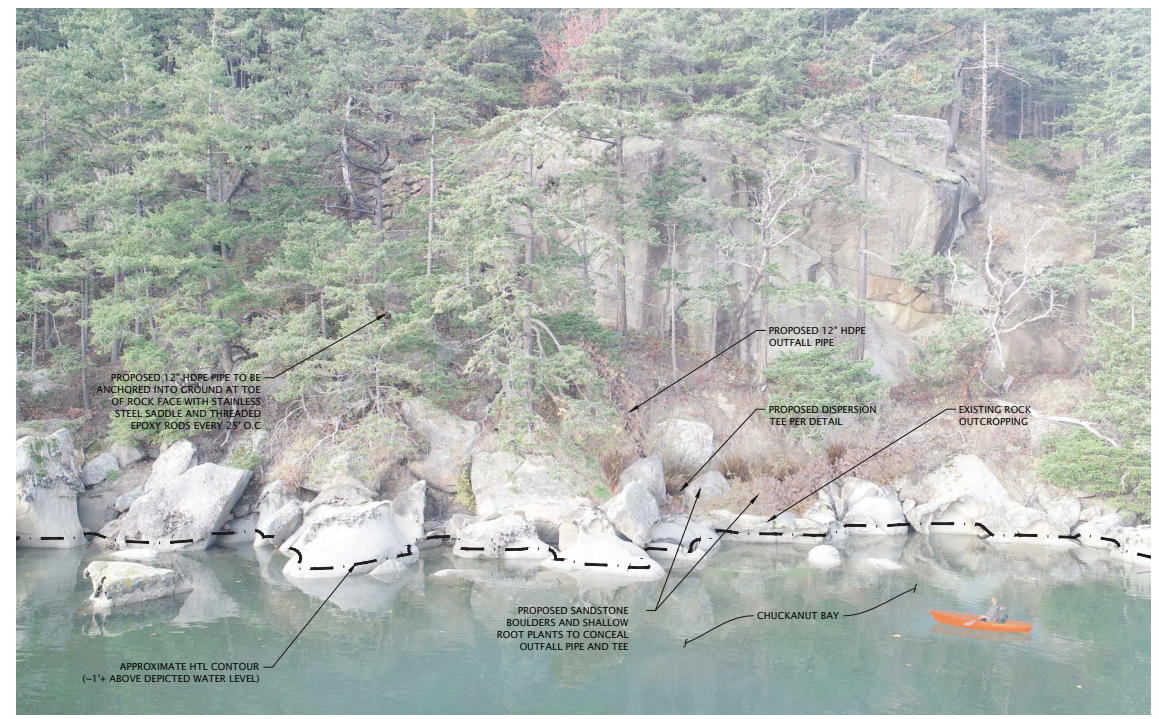

STORMWATER OUTFALL PIPE RENDERING

NTS

CALL BEFORE YOU DIG 1-800-424-5555

REVISION	DATE	DESCRIPTION	ISSUE	DATE	DESCRIPTION
1	9/13/2021	PRELIMINARY SITE PLAN			
2	10/18/2022	COB RFI REVISIONS			
3	6/09/2023	COB RFI 2 REVISIONS			
4	12/01/2023	COB RFI 3 REVISIONS			

ANN C. JONES FAMILY LP
 807 CHUCKANUT SHORE ROAD
 BELLINGHAM, WA 98229

THE WOODS AT VIEWCREST
 ESTATE PLANNING
 SITE IMPROVEMENTS
STORMWATER OUTFALL

PACIFIC SURVEYING & ENGINEERING, INC.
 909 Squillum Way, Suite 111 | BELLINGHAM, WA 98225
 T: 360.671.7387 | F: 360.671.4685
 WWW.PSESURVEY.COM | INFO@PSESURVEY.COM

DATA	DRAWN BY	CHECKED BY	FIELD BOOKS
BASE	-	-	DESIGN: -
DESIGN	RJR	JVY	STAKING: -
XREF:	-	-	ASBUILT: -
JOB#:	2019196		DATUM
HORIZ. SCALE:	SEE GRAPHIC SCALE		HORIZ.: NAD83
VERT. SCALE:	AS NOTED		VERT.: NAVD88
DWG:	P:\Pse Project\2019196\DWGs\SHEET\2019196_ocP_SP.dwg		
SHEET			8 OF 11

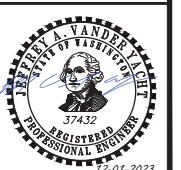

12-01-2023

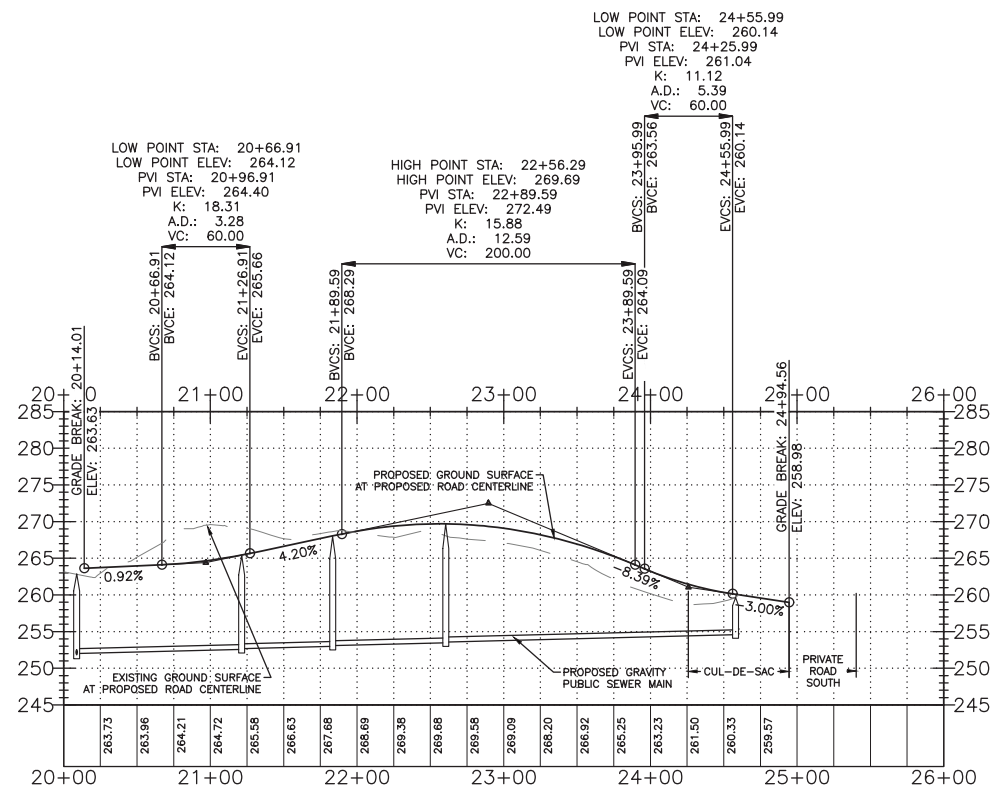

PUBLIC ROAD EAST PROFILE

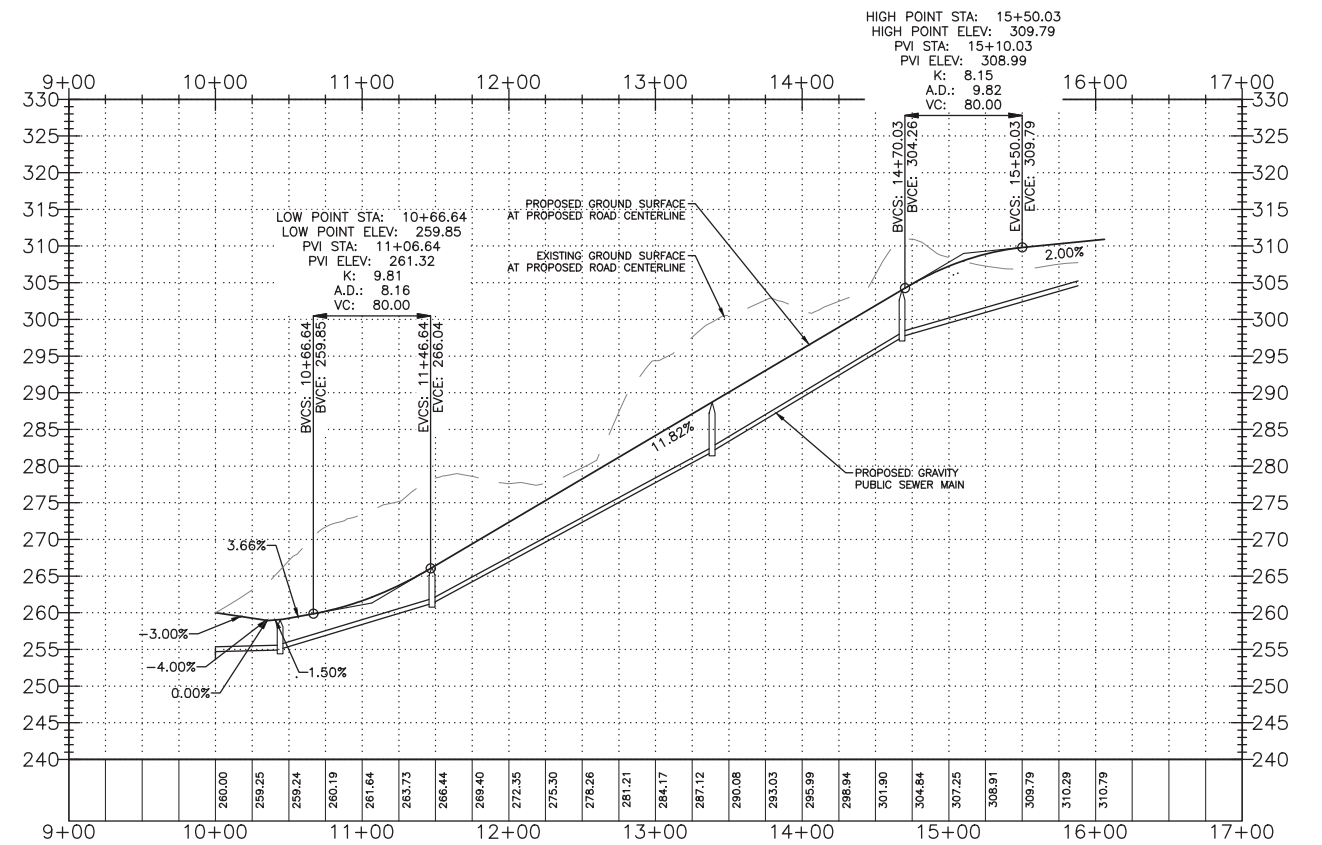

PRIVATE ROAD SOUTH PROFILE

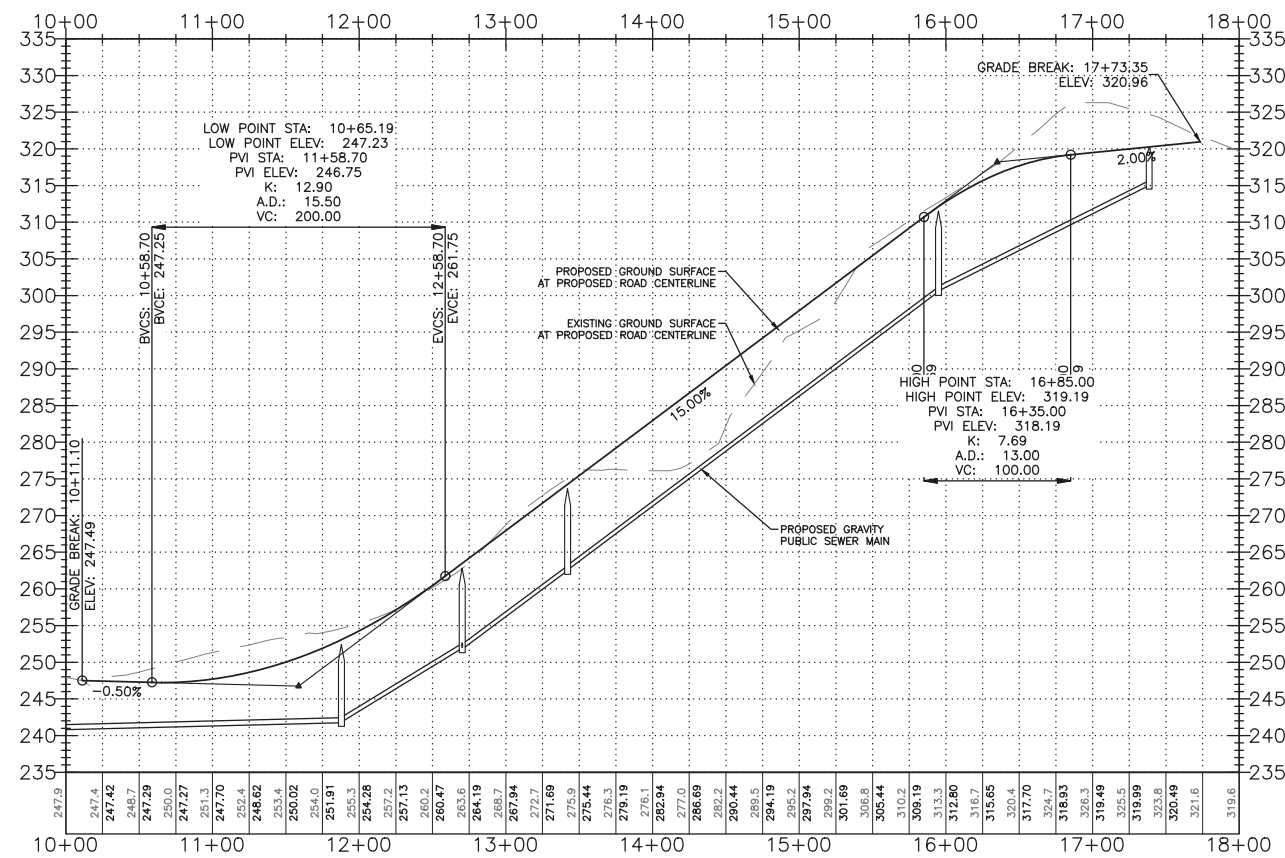

PUBLIC-WEST PROFILE

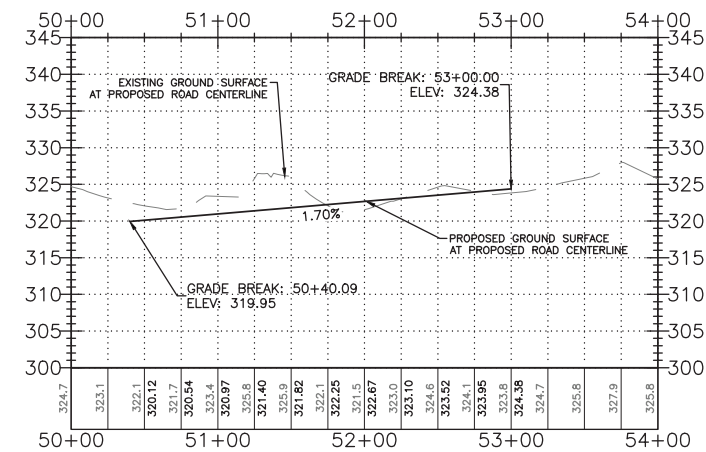

PRIVATE ROAD NORTH PROFILE

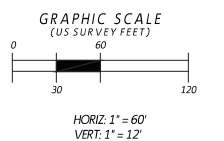

CALL BEFORE YOU DIG 1-800-424-5555

REVISION	DATE	DESCRIPTION	ISSUE	DATE	DESCRIPTION
			1	9/13/2021	PRELIMINARY SITE PLAN
			2	10/18/2022	COB RFI REVISIONS
			3	6/09/2023	COB RFI 2 REVISIONS
			4	12/01/2023	COB RFI 3 REVISIONS

ANN C. JONES FAMILY LP
807 CHUCKANUT SHORE ROAD
BELLINGHAM, WA 98229

THE WOODS AT VIEWCREST
ESTATE PLANNING
SITE IMPROVEMENTS
ROAD PROFILES

PACIFIC SURVEYING & ENGINEERING, INC.
909 Squallum Way, Suite 111 | BELLINGHAM, WA 98225
T: 360.671.7387 | F: 360.671.4685
WWW.PSESURVEY.COM | INFO@PSESURVEY.COM

DATA	DRAWN BY	CHECKED BY	FIELD BOOKS
BASE	-	-	DESIGN: -
DESIGN	RJR	JVY	STAKING: -
ASBUILT	-	-	ASBUILT: -
JOB#:	2019196		DATUM
HORIZ. SCALE:	SEE GRAPHIC SCALE		HORIZ.: NAD83
VERT. SCALE:	AS NOTED		VERT.: NAVD88
DWG:	P:\Pac Project\2019196\DWGS\SHEET\2019196_ocP_SP.dwg		
SHEET 9 OF 11			



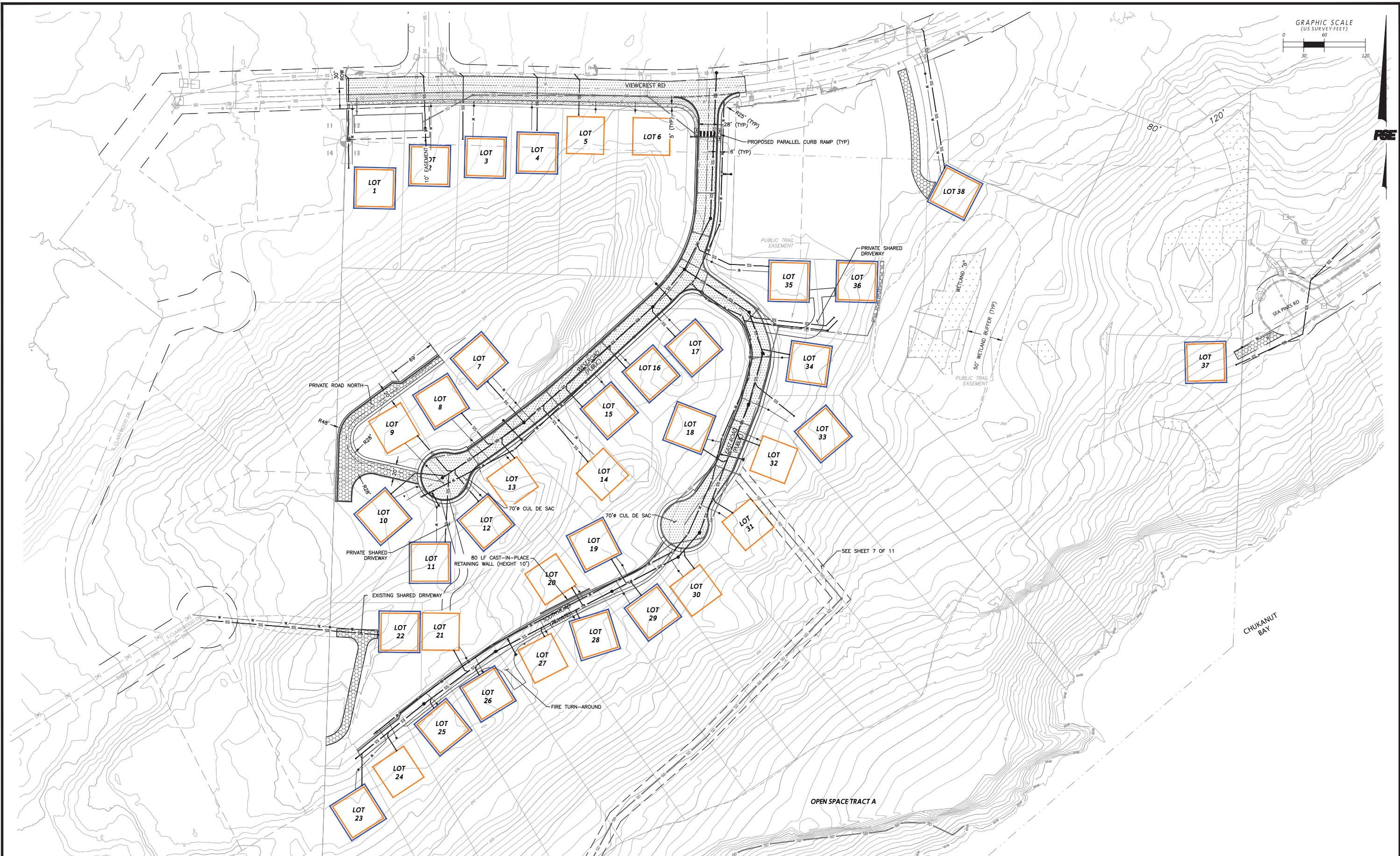

CALL BEFORE YOU DIG 1-800-424-5555

REVISION	DATE	DESCRIPTION	ISSUE	DATE	DESCRIPTION
1	9/13/2021	PRELIMINARY SITE PLAN			
2	10/18/2022	COB RFI REVISIONS			
3	6/09/2023	COB RFI 2 REVISIONS			
4	12/01/2023	COB RFI 3 REVISIONS			

ANN C. JONES FAMILY LP
 807 CHUKKANUT SHORE ROAD
 BELLINGHAM, WA 98229

THE WOODS AT VIEWCREST
 ESTATE PLANNING
 SITE IMPROVEMENTS

WATER & SANITARY SEWER PLAN



PACIFIC SURVEYING & ENGINEERING, INC.
 909 Squallum Way, Suite 111 | BELLINGHAM, WA 98225
 T. 360.671.7387 | F. 360.671.4685
 WWW.PSESURVEY.COM | INFO@PSESURVEY.COM

DATA	DRAWN BY	CHECKED BY	FIELD BOOKS
BASE	-	-	DESIGN: -
DESIGN	RIR	JVY	STAKING: -
XREF:	-	-	ASBUILT: -
JOB#:	2019196	-	DATUM
HORIZ. SCALE:	SEE GRAPHIC SCALE	-	HORIZ.: NAD83
VERT. SCALE:	AS NOTED	-	VERT.: NAVD88
DWG:	P:\Pse Project\2019196\DWGs_-SHEET\2019196_ocP_SP.dwg	-	-
SHEET 10 OF 11			

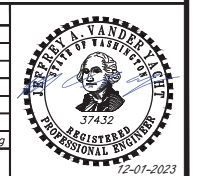

12-01-2023

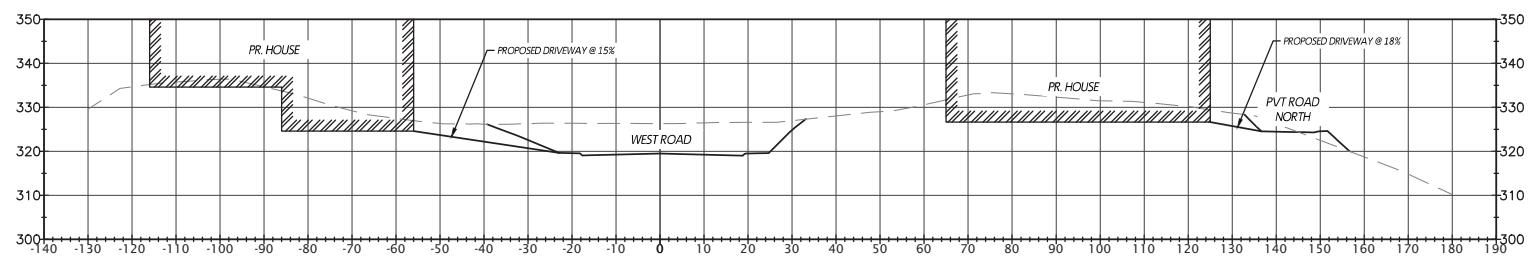
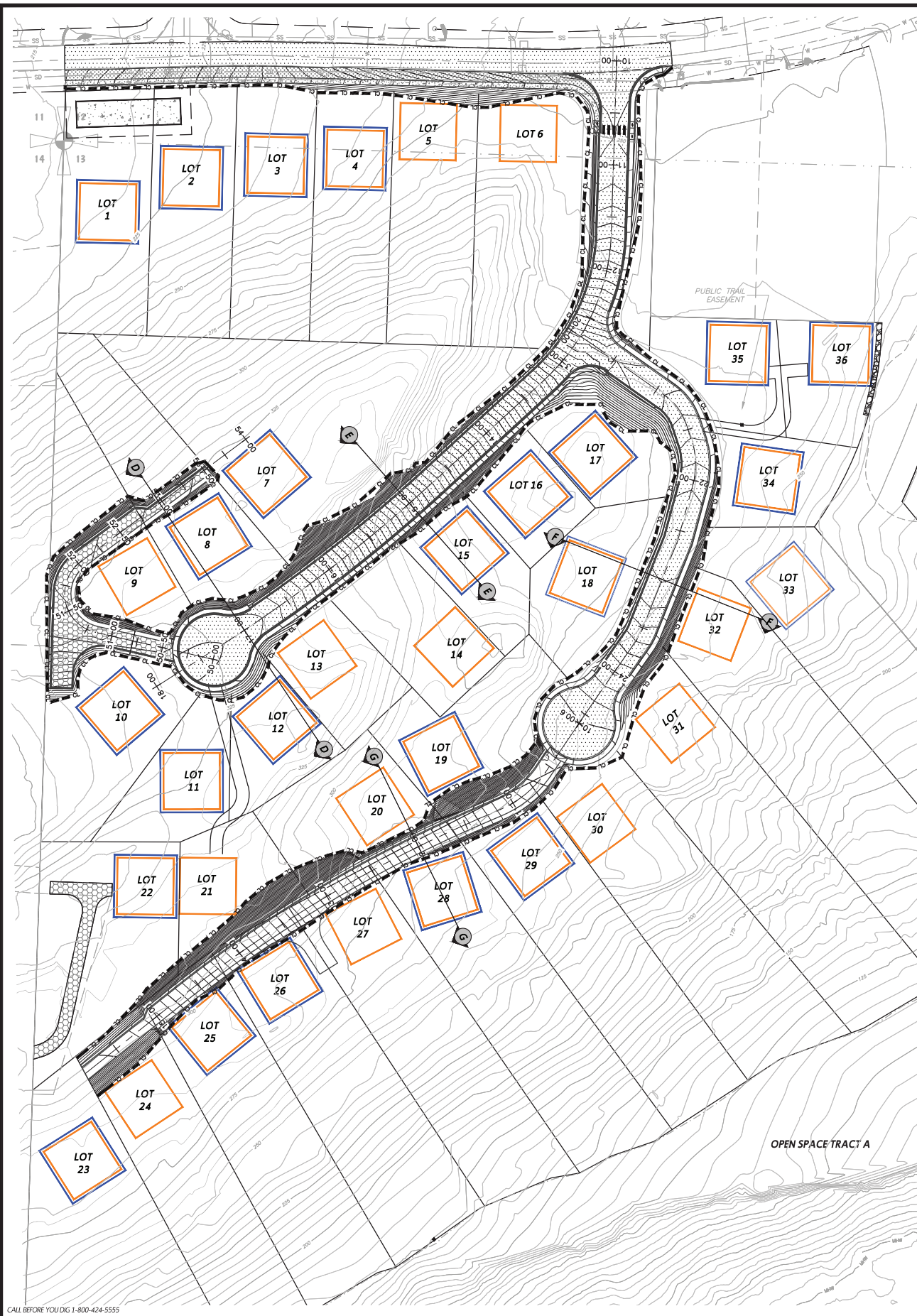

SECTION D-D
SCALE H: 1"=20' V: 1=20'

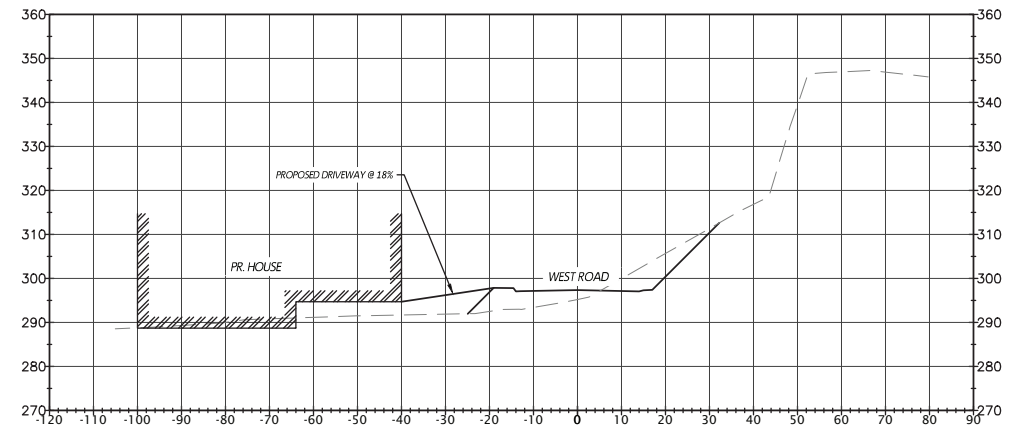

SECTION E-E
SCALE H: 1"=20' V: 1=20'

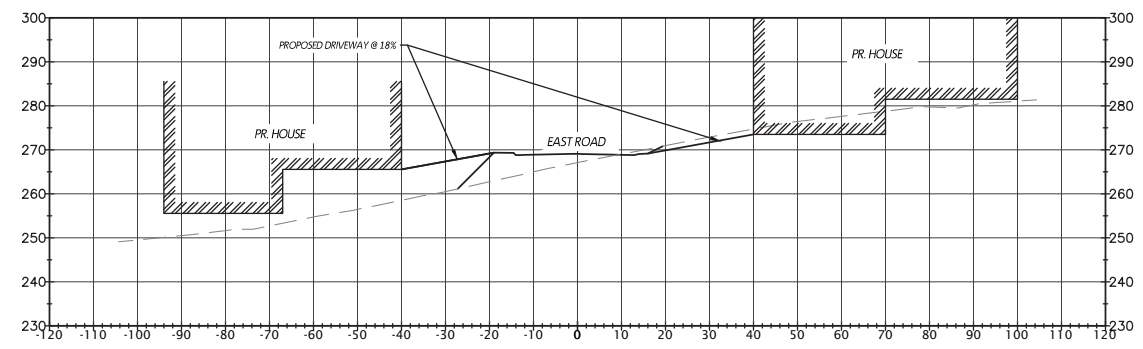

SECTION F-F
SCALE H: 1"=20' V: 1=20'

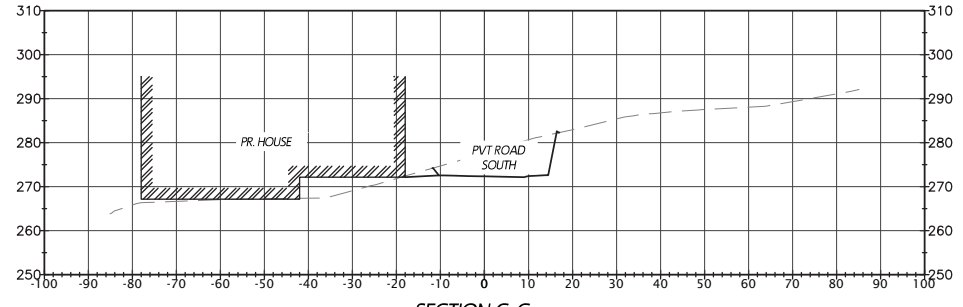

SECTION G-G
SCALE H: 1"=20' V: 1=20'

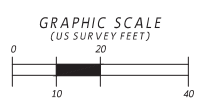

REVISION	DATE	DESCRIPTION	ISSUE	DATE	DESCRIPTION
1	9/13/2021	PRELIMINARY SITE PLAN			
2	10/18/2022	COB RFI REVISIONS			
3	6/09/2023	COB RFI 2 REVISIONS			
4	12/01/2023	COB RFI 3 REVISIONS			

ANN C. JONES FAMILY LP
807 CHUCKANUT SHORE ROAD
BELLINGHAM, WA 98229

THE WOODS AT VIEWCREST
ESTATE PLANNING
SITE IMPROVEMENTS
REPRESENTATIVE CROSS SECTIONS

PACIFIC SURVEYING & ENGINEERING, INC.
909 Squillum Way, Suite 111 | BELLINGHAM, WA 98225
T: 360.671.7387 | F: 360.671.4685
WWW.PSESURVEY.COM | INFO@PSESURVEY.COM

DATA	DRAWN BY	CHECKED BY	FIELD BOOKS
BASE	-	-	DESIGN: -
DESIGN	RJR	JVY	STAKING: -
XREF:	-	-	ASBUILT: -
JOB#:	2019196	-	DATUM
HORIZ. SCALE:	SEE GRAPHIC SCALE	-	NAD83
VERT. SCALE:	AS NOTED	-	NAVD88
DWG: P:\Pse Project\2019196\DWGs_-SHEET\2019196_ocP_SP.dwg	-	-	-
SHEET 11 OF 11			

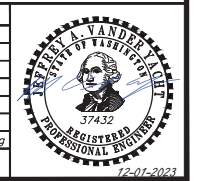

8.6 CRITICAL AREAS SUMMARY

MEMORANDUM

To: Susan Jones, Land Owner
From: Collin Van Slyke, Northwest Ecological Services (NES)
Date: October 31, 2021
RE: Wetland Delineation Update & Critical Areas Summary
for the Edgemoor Viewcrest Properties

BACKGROUND

Northwest Ecological Services, LLC (NES) was retained to provide an update to the 2010 Critical Areas Report for four parcels (#370212 030004; 370213 075542; -083499; - 113550) totaling approximately 34 acres, located in the Edgemoor neighborhood of Bellingham, Washington (Figure 1).

The parcels were reviewed for wetlands, streams, and other critical areas by Pacific Ecological Consultants in 2010. One wetland (Wetland A) was identified on site during the 2010 review. Since the critical areas report was prepared more than five years ago, an update is needed for projects involving critical area review.

Collin Van Slyke [Professional Wetland Scientist (PWS) #3129] and Michael Whitehurst, of NES, performed site visits June 22nd and 26th of 2020 and August 31st of 2021 to document the current site conditions. The NES site investigation was conducted in accordance with the *Regional Supplement to the Corps of Engineers Wetland Delineation Manual: Western Mountains, Valleys, and Coast Region* (Corps, 2010) and the *Corps of Engineers Wetland Delineation Manual* (Environmental Laboratory, 1987). This methodology is consistent with the WDOE's requirements established in 2011 (WAC 173-22-035) and the City of Bellingham (COB) Critical Areas Ordinance (CAO).

CURRENT CONDITIONS

The subject parcels are situated on a slope along the northwestern shore of the Chuckanut Bay Tidelands. The site generally exists in the same undeveloped and forested condition that was documented in the 2010 critical areas report. The exception to this is in a localized area in the central portion of the site where the forest understory was burned during a wildfire that occurred in 2019. In general, the site is vegetated with a mixed upland forest dominated by Douglas fir (*Pseudotsuga menziesii*), big leaf maple (*Acer macrophyllum*), salal (*Gaultheria shallon*), and sword fern (*Polystichum munitum*).

The 2010 report identified one slope wetland (Wetland A) in the northeastern corner of the site. NES observed Wetland A and also identified three additional slope wetlands (Wetlands B, C, and D) located in the nearby vicinity (Figure 2). NES collected data documenting wetland vegetation, soils, and hydrology indicators in each wetland (see attached data sheets). NES



NW ECOLOGICAL SERVICES

2801 Meridian St, Suite 202, Bellingham, WA 98225
nwecological.com | t 360.734.9484

delineated and marked the wetland boundaries in the field with pink flagging. The flags were surveyed by Pacific Survey and Engineering, Inc. (PSE) to produce Figure 3.

The site wetlands are summarized in Table 1 and described below.

Table 1. Wetland Classification Summary

Wetland	Hydrogeomorphic Class	Cowardin Classification	Size (square feet)
A	Slope	PFO	12,358
B	Slope	PFO	9,476
C	Slope	PFO	991
D	Slope	PEM/PSS	1,813

PFO: Palustrine Forested, PEM: Palustrine Emergent, PSS: Palustrine Scrub Shrub

Wetland A

Wetland A is a palustrine forested (PFO) slope wetland located in the northeastern corner of review area. Vegetation within Wetland A includes: red alder (*Alnus rubra*), Cascara (*Frangula purshiana*), salmonberry (*Rubus spectabilis*), black twinberry (*Lonicera involucrata*), Scouler's willow (*Salix scouleriana*), snowberry (*Symphoricarpos albus*), American skunk cabbage (*Lysichiton americanus*), American brooklime (*Veronica americana*), lady fern (*Athyrium filix-femina*), giant horsetail (*Equisetum telmateia*), Cooley's hedge nettle (*Stachys cooleyae*), Watson's willowherb (*Epilobium ciliatum*), creeping buttercup (*Ranunculus repens*), small bedstraw (*Gallium trifidum*), and bluegrass (*Poa sp.*). Invasive species, Himalayan blackberry (*Rubus armeniacus*) and Canada thistle (*Cirsium arvense*), were also present within Wetland A.

Hydrology to Wetland A appears to be driven by surface runoff and a groundwater seep. The wetland is seasonally saturated but also contains seasonal or occasional shallow water flowing-through above or just below the soil surface. Soil in the northern portion of the wetland was saturated to the surface at the time of the June site visit, but the remainder was dry due to the time of year. Water moves through the wetland from northwest to southeast. The wetland outlets to a ditch located between a residential driveway and the eastern wetland boundary. Water from the ditch flows east into a culvert under the driveway and is conveyed south towards Chuckanut Bay.

Wetland B

Wetland B is a PFO slope wetland located west of Wetland A. Wetland B is situated on an approximate seven degree slope, grading down to the southeast. The area flagged as Wetland B is contains two small upland hummocks located within the central area. Only one larger upland island was flagged within the wetland (Figure 3).

Vegetation observed in the wetland included: black cottonwood (*Populus balsamifera*), western red cedar (*Thuja plicata*), red alder, and Scouler's willow, Himalayan blackberry, American brooklime, and American skunk cabbage. Much of the ground within the wetland was bare.

The upland hummocks were vegetated with Douglas fir, salal, oceanspray (*Holodiscus discolor*), beaked hazelnut (*Corylus cornuta*), sword fern, and small bedstraw.

The wetland appears to be seasonally saturated only. Again, hydrology appears to be driven by surface runoff and a potentially a groundwater seep. Wetland B slopes down to the southeast to an old road grade, where water from the wetland appears to infiltrate.

Wetland C

Wetland C is a very small PFO slope wetland located between Wetlands A and B. The wetland contains almost no vegetation with the exception of a few red alder, red-osier dogwood, Scouler's willow, and snowberry.

The wetland was dry at the time of the site visits but appears to be seasonally saturated only. The wetland is located on an approximate five percent grade. Water from the wetland appears to outlet to the south and infiltrate into the forested upland.

Wetland D

Wetland D is a palustrine emergent/scrub-shrub (PEM/PSS) slope wetland located in the southeastern portion of the review area. Dominant vegetation within Wetland D included Nootka rose (*Rosa nutkana*), hardhack (*Spirea douglasii*), Himalayan blackberry, and black twinberry, giant horsetail, water parsley (*Oenanthe sarmentosa*), and American skunk cabbage.

Hydrology within Wetland D is similar to the other site wetlands with inputs including surface runoff and groundwater surfacing along the hillside. Water within Wetland D flows downslope to a rock headwall/boulder formation towards the grade break near the southern boundary of the review area. No surface connection to Chuckanut Bay was observed.

WDOE Ratings

NES rated the site wetlands using the updated 2014 Washington Department of Ecology (WDOE) Wetland Rating System for Western Washington. Wetland rating sheets are attached and summarized below in Table 2.

Table 2. Wetland Rating and Functional Assessment

Wetland	Improving Water Quality	Hydrologic	Habitat	Total Score	WDOE Category
A	L/M/L (4)	M/M/L (5)	L/L/M (4)	13	IV
B	L/M/L (4)	L/M/L (4)	L/L/M (4)	12	IV
C	L/L/L (3)	L/L/L (3)	L/L/M (4)	10	IV
D	L/L/L (3)	L/L/L (3)	L/L/M (4)	10	IV

Site potential score /landscape potential score/ value score (total points for function)
L=Low; M=Moderate, H=High

Streams, Shorelines, and Habitat Conservation Areas (HCAs)

Wetlands A and B contain large woody debris and snags meeting the Washington Department of Fish and Wildlife (WDFW) definition of Priority habitat features. Pileated woodpecker

(*Dryocopus pileatus*), a state Priority and Candidate listed species, excavations were observed within a snag in Wetland A. Due to the slope and lack ponding, no amphibian breeding habitat is assumed present within the any of the site wetlands.

A groundwater seep was observed in the central portion of the review area (Figure 3, Appendix B). Groundwater surfacing from a slight cut in topography flows downslope along an unvegetated trail. As documented in SP 102 (data sheets attached) this area did not contain hydric soil indicators and therefore does not meet wetland criteria.

No streams were mapped on-site in 2010 and none were observed during the 2020 site visit.

Chuckanut Bay is located along the entire southern boundary of the site. The ordinary high water mark (OHWM) along this shoreline is defined by exposed sandstone bedrock located at the toe of a moderately steep slope. The unvegetated bedrock wall is six to ten feet tall. The OHWM was not marked in the field (it would require spray painting the rock), but was mapped in Figure 2 using aerial imagery, LiDAR, and field notes. The beach and intertidal zone were unvegetated and the substrate consisted of a mix of cobble, gravel, and silt. Chuckanut Bay is mapped by WDFW to contain hardshell clam and shorebird concentrations (Priority Species/Habitats). No other Priority habitats or species are mapped or were identified on site.

DETERMINATION & REGULATORY SUMMARY

Table 3 summarizes agencies with regulatory authority over site critical areas and the anticipated buffers.

Table 3. Critical Areas Summary

Feature	WDOE Category/ Shoreline Designation	Regulatory Authority				Corps Hydrology Classification	Regulated Buffer (ft)*
		COB	Corps	WDOE	WDFW		
Wetland A	IV	X	X	X		Isolated	50
Wetland B	IV	X		X		Isolated	50
Wetland C	IV			X		Isolated	n/a
Wetland D	IV	X		X		Isolated	50
Chuckanut Bay	Natural	X	X	X	X	TNW	200

TNW= Traditional Navigable Water

* Buffer based on high intensity land use

City of Bellingham

The COB regulates all wetlands, regardless of size, with the exception of isolated Category III or IV wetlands smaller than 1,000 sq. ft. that do not provide suitably significant or unique characteristics as defined by the CAO (BMC 16.55.270). Wetlands A, B, and D are greater than 1,000 sq. ft. and are therefore expected to be regulated by the COB.

Wetland C is a Category IV wetland and is smaller than 1,000 sq. ft. **Therefore, Wetland C is not expected to be regulated by the COB and no buffer is required.**

The COB requires a buffer around regulated critical areas to protect functions. The buffer must remain naturally vegetated except where it can be enhanced to improve functions. It appears that a high intensity land use would apply to the proposed project based on housing density. Wetlands A and B are Category IV wetlands with low (four) habitat points. According to BMC 16.55.340(B), **Wetlands A, B, and D are expected to require 50-foot standard buffers (Figure 2).**

The COB CAO regulates Chuckanut Bay as an HCA. The COB Shoreline Management Program (SMP) designates this reach of shoreline (Marine 19) with a Natural designation. **The SMP requires a regulated buffer of 200 feet extending from the Chuckanut Bay OHWM.**

WDOE

WDOE has authority over discharge into all wetlands (including isolated wetlands) and streams and can impose buffers and compensatory mitigation for impacts (RCW 90.48).

Under Section 401 of the Clean Water Act (CWA), any activity involving a discharge into waters of the U.S. authorized under a Federal permit must receive a CWA Section 401 Water Quality Certification (WQC). WDOE is authorized to make WQC decisions on federal, public and private lands in Washington, with a few exceptions (where EPA or Tribes have authority). WDOE reviews all CWA Section 404 permit applications received by the Corps for WQC. WDOE requires an "individual" review of all wetland disturbances greater than one-half acre, or for projects in tidal waters or where impacts to wetlands and streams are determined to require additional review.

WDFW

The WDFW requires issuance of a Hydraulic Project Approval (HPA) prior to any activities that may directly or indirectly affect streams or associated wetlands. **WDFW is not expected to regulate the site wetlands due to lack of direct connectivity to a stream. WDFW is expected to regulate any activities proposed below the OHWM of Chuckanut Bay.** Only the WDFW has the authority to make this determination. Mitigation may be required for impacts.

U.S. Army Corps of Engineers

The Corps regulates the discharge of dredged or fill material into wetlands, streams, and other drainages that connect to Waters of the United States (WOTUS) under Section 404 of the CWA. The Corps regulates structures and/or work in or affecting the course, condition, or capacity of WOTUS under Section 10 of the Rivers and Harbors Act of 1899. The Corps requires notification for **all** disturbances to wetlands, streams, and potentially to other drainages (ditches). It is incumbent upon the landowner to disclose disturbances.

The Corps will automatically assert jurisdiction over some surface waters and will need to complete a "significant nexus" determination for others, depending on the degree of connection to other waters, the hydrologic classification of these associated waters, and their significance in the larger drainage basin. Wetland hydrologic classification and connectivity is described in this

report as the "Corps hydrologic classification" (Table 3) using definitions provided in current Corps guidance documents.

The Corps hydrologic classification is based on whether a surface water meets the definition of or is connected to a waterbody that meets the definition of a Traditional Navigable Water (TNW) or a Relatively Permanent Water (RPW). A TNW is a navigable water protected under Section 10 of the Rivers and Harbors Act of 1899 or other waters currently or historically used or susceptible to use in interstate or foreign commerce. An RPW is a surface stream or river that exhibits continuous flow of more than three months out of the year.

Only the Corps has the authority to make jurisdictional determinations; however, the following is a description of the anticipated determinations. Water outflowing from Wetlands B, C, and D appears to infiltrate into downslope upland areas. No direct surface connections to Chuckanut Bay (a TNW) were observed. **Therefore, Wetlands B, C, and D are not anticipated to be regulated by the Corps.** Wetland A outlets water to a ditch which conveys water to a culvert, eventually outfalling to Chuckanut Bay. This ditch does not appear to meet the definition of a tributary or RPW and therefore, **the Corps may potentially not regulate Wetland A.** However, a Jurisdictional Determination (JD) would need to be made by the Corps to confirm this if impacts to Wetland A were proposed.

Activities in Waters of the United States that require Corps authorization may qualify for authorization under one of the general Nationwide Permits (NWP) if the activities meet the criteria. In the more commonly used NWP, discharge (fill) is limited to under 1/2 acre of wetland, 300 linear feet of stream, and 1/3 acre of tidal waters. Discharge exceeding the NWP thresholds requires an Individual Permit from the Corps. Mitigation is required for most activities. The Corps also has discretion to disallow disturbance to high quality wetlands. As part of their permit review, the Corps must verify the project complies with Section 7 of the Endangered Species Act, the Magnuson-Stevens Fishery Conservation and Management Act, and Section 106 of the National Historic Preservation Act, (including archeological sites).

Site Plan

The preliminary plat (Attachment 4) depicts the proposed lot layout, roads, and future building sites. As depicted, the plat avoids impacts to all critical areas and buffers identified in this report.

ATTACHMENTS

Figures:

1. Vicinity Map
2. Critical Areas Overview Map
3. Wetlands Survey Map
4. Preliminary Plat

Photo Page

Data Sheets

Current WDOE Rating Forms



ECOLOGICAL





**Vicinity Map
(Google Maps)**

**Viewcrest Road
Wetland Delineation Update**

Figure 1

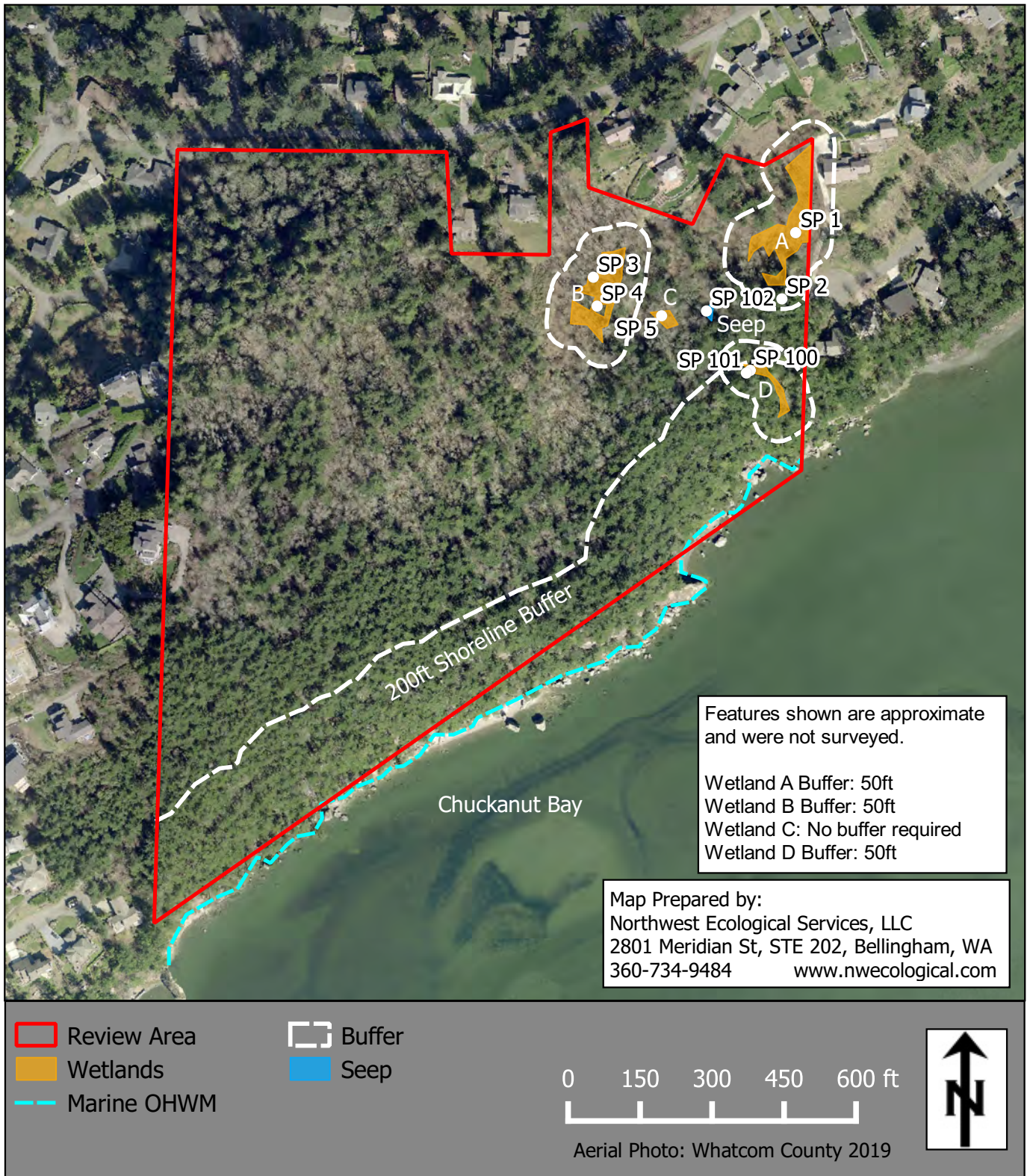
OCT 2021



<p>ECOLOGICAL</p>  <p>NORTHWEST</p>	<p>Critical Areas Overview Map</p> <p>Viewcrest Critical Areas Update</p>	<p>Figure 2</p> <p>OCT 2021</p>
--	---	--

EXISTING SYMBOL LEGEND:

- ⊕ - EXISTING TEST HOLE
- ⊖ - EXISTING TEST PIT

 = WETLAND PER NORTHWEST ECOLOGICAL SERVICES DELINEATION, SEPTEMBER 2021

GRAPHIC SCALE
(US SURVEY FEET)

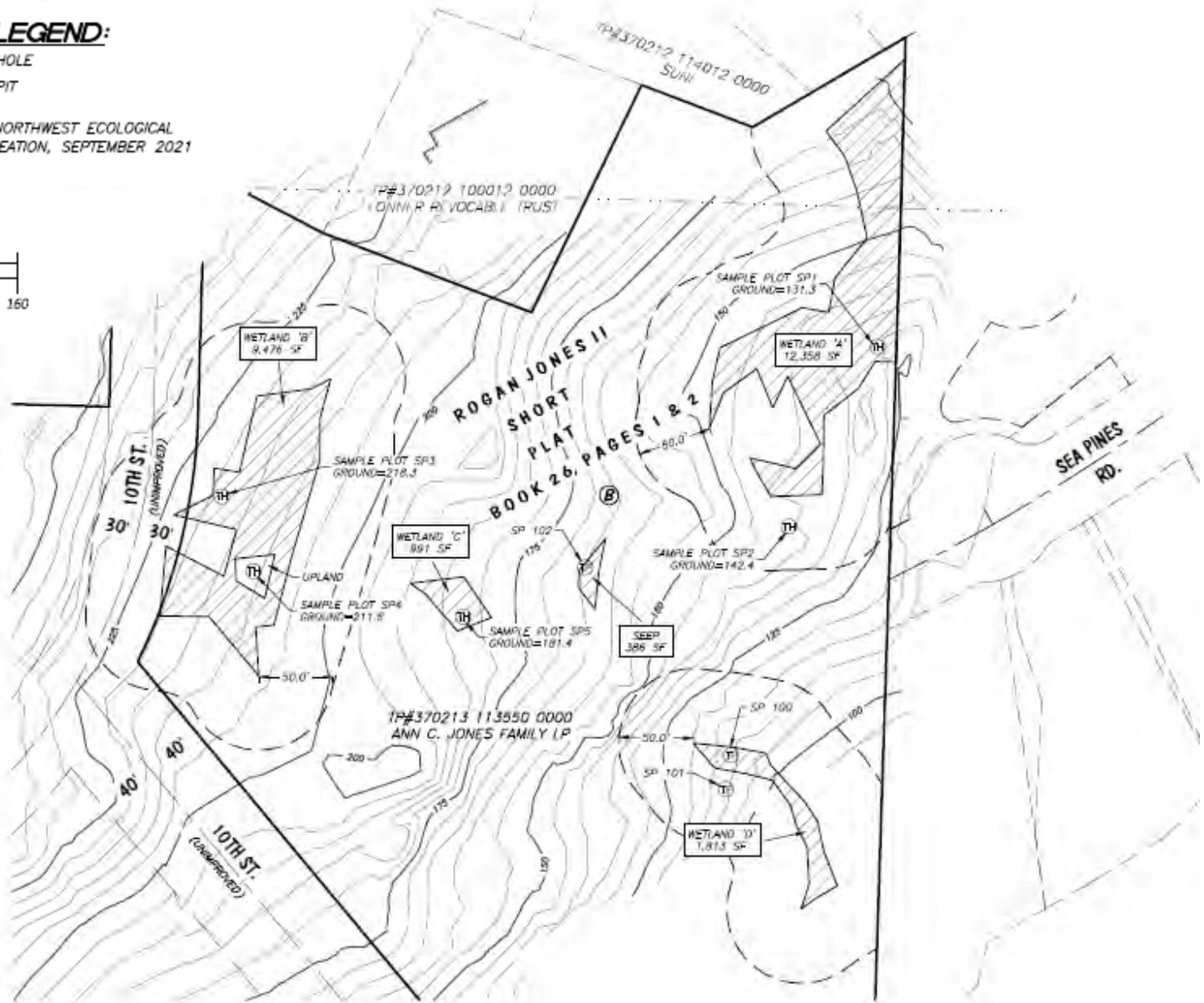
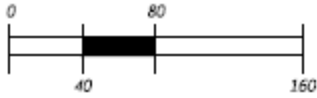

ECOLOGICAL

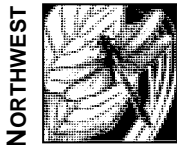



**Wetlands Survey Map
(PSE)**

**Viewcrest Road
Critical Areas Update**

Figure 3

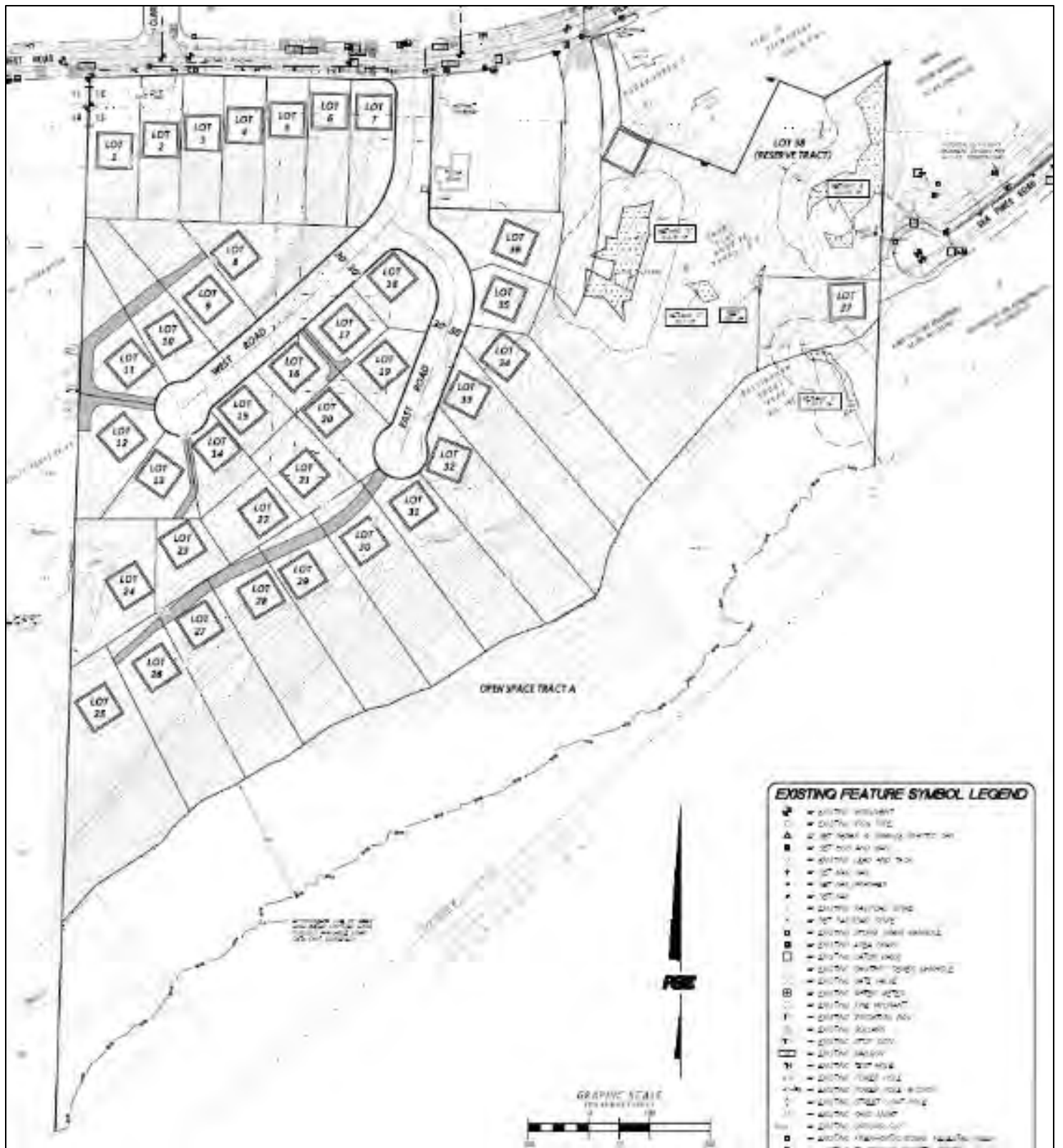
OCT 2021



<p>ECOLOGICAL</p> 	<p align="center">Preliminary Plat (PSE)</p> <p align="center">Viewcrest Road Critical Areas Update</p>	<p align="center">Figure 4</p> <p align="center">OCT 2021</p>
--	---	---



Detail of typical upland forest dominating most of site



Detail of area affected by past forest fire



Overview of Wetland A, looking west



Overview of Wetland A, looking northwest



Detail of Wetland B



Detail of Wetland B



Overview of Wetland C



Overview of Mud Bay shoreline and OHWM



Overview of Wetland D



Detail of Wetland D outlet



Overview of seep



Seep from downslope

WETLAND DETERMINATION DATA FORM – Western Mountain, Valley Coast Region

Project Site: Viewcrest City/County: Bellingham Sample Date: 06/22/20
 Applicant/Owner: Jones State: WA Sample Point: 01
 Investigator: Van Slyke; Whitehurst Section/Township/Range: 13/37N/02E
 Landform (hillslope, terrace, etc): slope Local Relief (concave, convex, none): Subregion: LRR A
 Soil Map Unit Name: Everett-Urban land complex NWI Classification: none
 Are climatic/hydrologic conditions on the site typical of this time of year? Yes No (if no, explain in Remarks)
 Are Vegetation , Soil , or Hydrology significantly disturbed? Are "Normal Circumstances" present? Yes No
 Are Vegetation , Soil , or Hydrology naturally problematic? (If needed, explain any answers in Remarks.)

SUMMARY OF FINDINGS – Attach site map showing sampling point locations, transects, important features, etc.

Hydrophytic Vegetation Present? Yes <input checked="" type="checkbox"/> No <input type="checkbox"/>	Is the Sampled Area within a Wetland? Yes <input checked="" type="checkbox"/> No <input type="checkbox"/>
Hydric Soil Present? Yes <input checked="" type="checkbox"/> No <input type="checkbox"/>	
Wetland Hydrology Present? Yes <input checked="" type="checkbox"/> No <input type="checkbox"/>	
Remarks: Wetland A. Positive indicators for all three parameters were observed at this location.	

VEGETATION

Tree Stratum (Plot size: 30 feet)	Absolute % Cover	Indicator Status	Dominant Species?	Dominance Test worksheet	
<i>Alnus rubra</i>	90	FAC	<input checked="" type="checkbox"/>	Number of Dominant Species that are OBL, FACW, or FAC:	5+
<i>Rhamnus purshiana</i>	5	FAC	<input type="checkbox"/>		
	-	-	<input type="checkbox"/>		
	-	-	<input type="checkbox"/>		
Total Cover:	95			Total number of dominant species across all strata:	8 (A)
Sapling/Shrub Stratum (Plot size: 15 feet)				Percent of dominant species that are OBL, FACW, FAC:	62+
<i>Symphoricarpos albus</i>	20	FACU	<input checked="" type="checkbox"/>	Prevalence Index worksheet	(A/AB)
<i>Rubus spectabilis</i>	15	FAC	<input checked="" type="checkbox"/>		
<i>Lonicera involucrata</i>	10	FAC	<input checked="" type="checkbox"/>		
				OBL species:	x 1=
				FACW species:	x 2=
				FAC species:	x 3=
				FACU species:	x 4=
				UPL species:	x 5=
Total Cover:	45			Total: (A)	(B)
Herb Stratum (Plot size: 5 feet)				Prevalence Index = B/A =	
<i>Poa sp.</i>	60	-	<input checked="" type="checkbox"/>	Hydrophytic Vegetation Indicators:	
<i>Lysichiton americanus</i>	20	OBL	<input checked="" type="checkbox"/>		
<i>Equisetum telmateia</i>	20	FACW	<input checked="" type="checkbox"/>		
<i>Athyrium filix-femina</i>	10	FAC	<input type="checkbox"/>		
<i>Cirsium arvense</i>	10	FAC	<input type="checkbox"/>		
<i>Veronica americana</i>	5	OBL	<input type="checkbox"/>	<input type="checkbox"/> Dominance Test is > 50% <input type="checkbox"/> Prevalence Index is ≤3.0 ¹ <input type="checkbox"/> Morphological Adaptations ¹ (provide supporting data in Remarks or on a separate sheet) <input type="checkbox"/> Wetland Non-Vascular Plants ¹ <input type="checkbox"/> Problematic Hydrophytic Vegetation ¹ ¹ Indicators of hydric soil and wetland hydrology must be present.	
Total Cover:	125				
Woody Vine Stratum (Plot size: 30 feet)					
<i>Rubus armeniacus</i>	5	FAC	<input checked="" type="checkbox"/>		
Total Cover:	5				
% Bare Ground in Herb Stratum: 0					
Remarks: The majority of dominant species observed at this location were hydrophytic. <i>Poa</i> species is undetermined.				Hydrophytic Vegetation Present? Yes <input checked="" type="checkbox"/> No <input type="checkbox"/>	

SOIL

Sample Point: 01

Profile Description: (Describe to the depth needed to document the indicator or confirm the absence of indicators.)

Depth (inches)	Soil Color		Redox Features				Texture	Remarks
	Color (moist)	%	Color (moist)	%	Type ¹	Loc ²		
0-8	10YR 2/2	95	10YR 4/6	5	C	M	silt loam	
8-16	2.5Y 4/2	60	10YR 5/6	40	C	M	sandy silt loam	
					-	-		
					-	-		
					-	-		
					-	-		
					-	-		
					-	-		

¹Type: C=concentration D=depletion RM=reduced matrix ²Location: PL=pore lining RC=root channel M=matrix

Hydric Soil Indicators: (applicable to all LRRs unless otherwise noted)		Indicators for Problematic Hydric Soils³:
<input type="checkbox"/> Histosol (A1) <input type="checkbox"/> Histic Epipedon (A2) <input type="checkbox"/> Black Histic (A3) <input type="checkbox"/> Hydrogen Sulfide (A4) <input checked="" type="checkbox"/> Depleted Below Dark Surface (A11) <input type="checkbox"/> Thick Dark Surface (A12) <input type="checkbox"/> Sandy Mucky Mineral (S1) <input type="checkbox"/> Sandy Gleyed Matrix (S4)	<input type="checkbox"/> Sandy Redox (S5) <input type="checkbox"/> Stripped Matrix (S6) <input type="checkbox"/> Loamy Mucky Mineral (F1) (except MLRA 1) <input type="checkbox"/> Loamy Gleyed Matrix (F2) <input checked="" type="checkbox"/> Depleted Matrix (F3) <input checked="" type="checkbox"/> Redox Dark Surface (F6) <input type="checkbox"/> Depleted Dark Surface (F7) <input type="checkbox"/> Redox Depressions (F8)	<input type="checkbox"/> 2 cm Muck (A10) <input type="checkbox"/> Red parent material (TF2) <input type="checkbox"/> Very shallow dark surface (TF12) <input type="checkbox"/> Other (Explain in Remarks)
Restrictive Layer (if present): Type: Depth (inches):		Hydric Soil Present? Yes <input checked="" type="checkbox"/> No <input type="checkbox"/>
Remarks: Soil at this location met NRCS hydric soil indicators A11, F3, and F6.		

HYDROLOGY

Wetland hydrology Indicators:		Secondary Indicators (2 or more required)
Primary Indicators (any one indicator is sufficient)		
<input type="checkbox"/> Surface Water (A1) <input checked="" type="checkbox"/> High Water Table (A2) <input checked="" type="checkbox"/> Saturation (A3) <input type="checkbox"/> Water marks (B1) <input type="checkbox"/> Sediment Deposits (B2) <input type="checkbox"/> Drift Deposits (B3) <input type="checkbox"/> Algal Mat or Crust (B4) <input type="checkbox"/> Iron Deposits (B5) <input type="checkbox"/> Surface Soil Cracks (B6) <input type="checkbox"/> Inundation Visible on Aerial Imagery (B7)	<input type="checkbox"/> Sparsely Vegetated Concave Surface (B8) <input type="checkbox"/> Water-stained Leaves (B9) (except MLRA 1, 2, 4A and 4B) <input type="checkbox"/> Salt Crust (B11) <input type="checkbox"/> Aquatic Invertebrates (B13) <input type="checkbox"/> Hydrogen Sulfide Odor (C1) <input type="checkbox"/> Oxidized Rhizospheres along living roots (C3) <input type="checkbox"/> Presence of Reduced Iron (C4) <input type="checkbox"/> Recent Iron Reduction in Tilled Soils (C6) <input type="checkbox"/> Stunted or Stresses Plants (D1) (LRR A) <input type="checkbox"/> Other (Explain in Remarks)	<input type="checkbox"/> Water-stained (B9) (MLRA 1, 2, 4A, and 4B) <input checked="" type="checkbox"/> Drainage Patterns (B10) <input type="checkbox"/> Dry-season Water Table (C2) <input type="checkbox"/> Saturation Visible on Aerial Imagery (C9) <input type="checkbox"/> Geomorphic Position (D2) <input type="checkbox"/> Shallow Aquitard (D3) <input type="checkbox"/> Frost-heave Hummocks (D7) <input type="checkbox"/> FAC-neutral (D5)
Field Observations: Surface Water Present? Yes <input type="checkbox"/> No <input checked="" type="checkbox"/> Depth (inches): Water Table Present? Yes <input checked="" type="checkbox"/> No <input type="checkbox"/> Depth (inches): -10 Saturation Present? Yes <input checked="" type="checkbox"/> No <input type="checkbox"/> Depth (inches): -10 (include capillary fringe)		Wetland Hydrology Present? Yes <input checked="" type="checkbox"/> No <input type="checkbox"/>
Describe Recorded Data (stream gauge, monitoring well, aerial photos, previous inspections), if available:		
Remarks: Soil was saturated at -10 inches.		

WETLAND DETERMINATION DATA FORM – Western Mountain, Valley Coast Region

Project Site: Viewcrest City/County: Bellingham Sample Date: 06/22/20
 Applicant/Owner: Jones State: WA Sample Point: 02
 Investigator: Van Slyke; Whitehurst Section/Township/Range: 13/37N/02E
 Landform (hillslope, terrace, etc): slope Local Relief (concave, convex, none) : Subregion: LRR A
 Soil Map Unit Name: Everett-Urban land complex NWI Classification: none
 Are climatic/hydrologic conditions on the site typical of this time of year? Yes No (if no, explain in Remarks)
 Are Vegetation , Soil , or Hydrology significantly disturbed? Are "Normal Circumstances" present? Yes No
 Are Vegetation , Soil , or Hydrology naturally problematic? (If needed, explain any answers in Remarks.)

SUMMARY OF FINDINGS – Attach site map showing sampling point locations, transects, important features, etc.

Hydrophytic Vegetation Present? Yes <input type="checkbox"/> No <input checked="" type="checkbox"/>	Is the Sampled Area within a Wetland? Yes <input type="checkbox"/> No <input checked="" type="checkbox"/>
Hydric Soil Present? Yes <input checked="" type="checkbox"/> No <input type="checkbox"/>	
Wetland Hydrology Present? Yes <input type="checkbox"/> No <input checked="" type="checkbox"/>	
Remarks: Upland adjacent to Wetland A. Positive indicators for all three parameters were not observed at this location.	

VEGETATION

Tree Stratum (Plot size: 30 feet)	Absolute % Cover	Indicator Status	Dominant Species?	Dominance Test worksheet	
<i>Pseudotsuga menziesii</i>	50	FACU	<input checked="" type="checkbox"/>	Number of Dominant Species that are OBL, FACW, or FAC:	1 (A)
<i>Thuja plicata</i>	20	FAC	<input checked="" type="checkbox"/>		
		-	<input type="checkbox"/>		
		-	<input type="checkbox"/>		
Total Cover:	70			Total number of dominant species across all strata:	5 (AB)
Sapling/Shrub Stratum (Plot size: 15 feet)				Percent of dominant species that or OBL, FACW, FAC:	20 (A/AB)
<i>Gaultheria shallon</i>	65	FACU	<input checked="" type="checkbox"/>	Prevalence Index worksheet	
<i>Oemleria cerasiformis</i>	40	FACU	<input checked="" type="checkbox"/>		
<i>Corylus cornuta</i>	15	FACU	<input type="checkbox"/>		
<i>Rosa gymnocarpa</i>	10	FACU	<input type="checkbox"/>		
Total Cover:	130			OBL species: x 1=	
				FACW species: x 2=	
				FAC species: x 3=	
				FACU species: x 4=	
				UPL species: x 5=	
Total Cover:	5			Total: (A)	(B)
Herb Stratum (Plot size: 5 feet)				Prevalence Index = B/A =	
<i>Pteridium aquilinum</i>	5	FACU	<input checked="" type="checkbox"/>	Hydrophytic Vegetation Indicators:	
		-	<input type="checkbox"/>		
		-	<input type="checkbox"/>		
		-	<input type="checkbox"/>		
Total Cover:	5			<input type="checkbox"/> Dominance Test is > 50%	
				<input type="checkbox"/> Prevalence Index is ≤3.0 ¹	
				<input type="checkbox"/> Morphological Adaptations ¹ (provide supporting data in Remarks or on a separate sheet)	
				<input type="checkbox"/> Wetland Non-Vascular Plants ¹	
				<input type="checkbox"/> Problematic Hydrophytic Vegetation ¹	
Total Cover:	0			¹ Indicators of hydric soil and wetland hydrology must be present.	
% Bare Ground in Herb Stratum: 20				Hydrophytic Vegetation Present? Yes <input type="checkbox"/> No <input checked="" type="checkbox"/>	
Remarks: The majority of dominant species observed at this location were not hydrophytic.					

SOIL

Sample Point: 02

Profile Description: (Describe to the depth needed to document the indicator or confirm the absence of indicators.)

Depth (inches)	Soil Color		Redox Features				Texture	Remarks
	Color (moist)	%	Color (moist)	%	Type ¹	Loc ²		
+1					-	-		Duff
0-2	10YR 3/2	100			-	-	loam	
2-16	10YR 6/1	99	2.5Y 6/4	1	C	M	silt loam	
					-	-		
					-	-		
					-	-		
					-	-		

¹Type: C=concentration D=depletion RM=reduced matrix ²Location: PL=pore lining RC=root channel M=matrix

Hydric Soil Indicators: (applicable to all LRRs unless otherwise noted)	Indicators for Problematic Hydric Soils³:
<input type="checkbox"/> Histosol (A1) <input type="checkbox"/> Histic Epipedon (A2) <input type="checkbox"/> Black Histic (A3) <input type="checkbox"/> Hydrogen Sulfide (A4) <input checked="" type="checkbox"/> Depleted Below Dark Surface (A11) <input type="checkbox"/> Thick Dark Surface (A12) <input type="checkbox"/> Sandy Mucky Mineral (S1) <input type="checkbox"/> Sandy Gleyed Matrix (S4)	<input type="checkbox"/> Sandy Redox (S5) <input type="checkbox"/> Stripped Matrix (S6) <input type="checkbox"/> Loamy Mucky Mineral (F1) (except MLRA 1) <input type="checkbox"/> Loamy Gleyed Matrix (F2) <input type="checkbox"/> Depleted Matrix (F3) <input type="checkbox"/> Redox Dark Surface (F6) <input type="checkbox"/> Depleted Dark Surface (F7) <input type="checkbox"/> Redox Depressions (F8)
Restrictive Layer (if present): Type: _____ Depth (inches): _____	
Hydric Soil Present? Yes <input type="checkbox"/> No <input checked="" type="checkbox"/>	
Remarks: Soil at this location does not meet NRCS hydric soil indicators.	

HYDROLOGY

Wetland hydrology Indicators: Primary Indicators (any one indicator is sufficient)	Secondary Indicators (2 or more required)
<input type="checkbox"/> Surface Water (A1) <input type="checkbox"/> High Water Table (A2) <input type="checkbox"/> Saturation (A3) <input type="checkbox"/> Water marks (B1) <input type="checkbox"/> Sediment Deposits (B2) <input type="checkbox"/> Drift Deposits (B3) <input type="checkbox"/> Algal Mat or Crust (B4) <input type="checkbox"/> Iron Deposits (B5) <input type="checkbox"/> Surface Soil Cracks (B6) <input type="checkbox"/> Inundation Visible on Aerial Imagery (B7)	<input type="checkbox"/> Sparsely Vegetated Concave Surface (B8) <input type="checkbox"/> Water-stained Leaves (B9) (except MLRA 1, 2, 4A and 4B) <input type="checkbox"/> Salt Crust (B11) <input type="checkbox"/> Aquatic Invertebrates (B13) <input type="checkbox"/> Hydrogen Sulfide Odor (C1) <input type="checkbox"/> Oxidized Rhizospheres along living roots (C3) <input type="checkbox"/> Presence of Reduced Iron (C4) <input type="checkbox"/> Recent Iron Reduction in Tilled Soils (C6) <input type="checkbox"/> Stunted or Stresses Plants (D1) (LRR A) <input type="checkbox"/> Other (Explain in Remarks)
Field Observations: Surface Water Present? Yes <input type="checkbox"/> No <input checked="" type="checkbox"/> Depth (inches): _____ Water Table Present? Yes <input type="checkbox"/> No <input checked="" type="checkbox"/> Depth (inches): _____ Saturation Present? Yes <input type="checkbox"/> No <input checked="" type="checkbox"/> Depth (inches): _____ (include capillary fringe)	
Wetland Hydrology Present? Yes <input type="checkbox"/> No <input checked="" type="checkbox"/>	
Describe Recorded Data (stream gauge, monitoring well, aerial photos, previous inspections), if available:	
Remarks: Soils were dry, and no hydrology indicators were observed.	

WETLAND DETERMINATION DATA FORM – Western Mountain, Valley Coast Region

Project Site: Viewcrest City/County: Bellingham Sample Date: 06/26/20
 Applicant/Owner: Jones State: WA Sample Point: 03
 Investigator: Van Slyke; Whitehurst Section/Township/Range: 13/37N/02E
 Landform (hillslope, terrace, etc): slope Local Relief (concave, convex, none): Subregion: LRR A
 Soil Map Unit Name: Nati Loam NWL Classification: none
 Are climatic/hydrologic conditions on the site typical of this time of year? Yes No (if no, explain in Remarks)
 Are Vegetation , Soil , or Hydrology significantly disturbed? Are "Normal Circumstances" present? Yes No
 Are Vegetation , Soil , or Hydrology naturally problematic? (If needed, explain any answers in Remarks.)

SUMMARY OF FINDINGS – Attach site map showing sampling point locations, transects, important features, etc.

Hydrophytic Vegetation Present? Yes <input checked="" type="checkbox"/> No <input type="checkbox"/>	Is the Sampled Area within a Wetland? Yes <input checked="" type="checkbox"/> No <input type="checkbox"/>
Hydric Soil Present? Yes <input checked="" type="checkbox"/> No <input type="checkbox"/>	
Wetland Hydrology Present? Yes <input checked="" type="checkbox"/> No <input type="checkbox"/>	
Remarks: Wetland B. Positive indicators for all three parameters were observed at this location.	

VEGETATION

Tree Stratum (Plot size: 30 feet)	Absolute % Cover	Indicator Status	Dominant Species?	Dominance Test worksheet	
<i>Alnus rubra</i>	30	FAC	<input checked="" type="checkbox"/>	Number of Dominant Species that are OBL, FACW, or FAC:	3
<i>Acer macrophyllum</i>	25	FACU	<input checked="" type="checkbox"/>		
	-	-	<input type="checkbox"/>		
	-	-	<input type="checkbox"/>	Total number of dominant species across all strata:	6
Total Cover:	55				(AB)
Sapling/Shrub Stratum (Plot size: 15 feet)	Percent of dominant species that or OBL, FACW, FAC:				50
<i>Symphoricarpos albus</i>	10	FACU	<input checked="" type="checkbox"/>		(A/AB)
	-	-	<input type="checkbox"/>		
	-	-	<input type="checkbox"/>		
	-	-	<input type="checkbox"/>		
Total Cover:	10				
Herb Stratum (Plot size: 5 feet)	Prevalence Index worksheet				
				OBL species: 20	x 1= 20
				FACW species: 0	x 2= 0
				FAC species: 45	x 3= 135
				FACU species: 40	x 4= 160
<i>Veronica americana</i>	20	OBL	<input checked="" type="checkbox"/>	UPL species: 0	x 5= 0
<i>Rubus ursinus</i>	5	FACU	<input checked="" type="checkbox"/>	Total: 105	(A) 315 (B)
	-	-	<input type="checkbox"/>	Prevalence Index = B/A = 3.0	
	-	-	<input type="checkbox"/>	Hydrophytic Vegetation Indicators:	
	-	-	<input type="checkbox"/>	<input type="checkbox"/> Dominance Test is > 50%	
	-	-	<input type="checkbox"/>	<input checked="" type="checkbox"/> Prevalence Index is ≤3.0 ¹	
	-	-	<input type="checkbox"/>	<input type="checkbox"/> Morphological Adaptations ¹ (provide supporting data in Remarks or on a separate sheet)	
Total Cover:	25			<input type="checkbox"/> Wetland Non-Vascular Plants ¹	
				<input type="checkbox"/> Problematic Hydrophytic Vegetation ¹	
				¹ Indicators of hydric soil and wetland hydrology must be present.	
Woody Vine Stratum (Plot size: 30 feet)					
<i>Rubus armeniacus</i>	15	FAC	<input checked="" type="checkbox"/>		
	-	-	<input type="checkbox"/>		
	-	-	<input type="checkbox"/>		
Total Cover:	15				
% Bare Ground in Herb Stratum: 80					
Remarks: The majority of dominant species observed at this location were hydrophytic based on the prevalence index.				Hydrophytic Vegetation Present? Yes <input checked="" type="checkbox"/> No <input type="checkbox"/>	

SOIL

Sample Point: 03

Profile Description: (Describe to the depth needed to document the indicator or confirm the absence of indicators.)

Depth (inches)	Soil Color		Redox Features				Texture	Remarks
	Color (moist)	%	Color (moist)	%	Type ¹	Loc ²		
0-11	10YR 3/2	80	10YR 4/4	20	C	RC	fine sandy silt loam	
11-16	10YR 4/4	60	10YR 4/6	10	C	M	clayey silt loam	
	2.5Y 5/3	30			-	-		
					-	-		
					-	-		
					-	-		
					-	-		

¹Type: C=concentration D=depletion RM=reduced matrix ²Location: PL=pore lining RC=root channel M=matrix

Hydric Soil Indicators: (applicable to all LRRs unless otherwise noted)		Indicators for Problematic Hydric Soils³:
<input type="checkbox"/> Histosol (A1)	<input type="checkbox"/> Sandy Redox (S5)	<input type="checkbox"/> 2 cm Muck (A10)
<input type="checkbox"/> Histic Epipedon (A2)	<input type="checkbox"/> Stripped Matrix (S6)	<input type="checkbox"/> Red parent material (TF2)
<input type="checkbox"/> Black Histic (A3)	<input type="checkbox"/> Loamy Mucky Mineral (F1) (except MLRA 1)	<input type="checkbox"/> Very shallow dark surface (TF12)
<input type="checkbox"/> Hydrogen Sulfide (A4)	<input type="checkbox"/> Loamy Gleyed Matrix (F2)	<input type="checkbox"/> Other (Explain in Remarks)
<input type="checkbox"/> Depleted Below Dark Surface (A11)	<input type="checkbox"/> Depleted Matrix (F3)	
<input type="checkbox"/> Thick Dark Surface (A12)	<input checked="" type="checkbox"/> Redox Dark Surface (F6)	
<input type="checkbox"/> Sandy Mucky Mineral (S1)	<input type="checkbox"/> Depleted Dark Surface (F7)	
<input type="checkbox"/> Sandy Gleyed Matrix (S4)	<input type="checkbox"/> Redox Depressions (F8)	
Restrictive Layer (if present):		
Type:		
Depth (inches):		Hydric Soil Present? Yes <input checked="" type="checkbox"/> No <input type="checkbox"/>
Remarks: Soil at this location met NRCS hydric soil indicator F6.		

HYDROLOGY

Wetland hydrology Indicators:	Secondary Indicators (2 or more required)
Primary Indicators (any one indicator is sufficient)	
<input type="checkbox"/> Surface Water (A1)	<input type="checkbox"/> Sparsely Vegetated Concave Surface (B8)
<input type="checkbox"/> High Water Table (A2)	<input type="checkbox"/> Water-stained Leaves (B9) (except MLRA 1, 2, 4A and 4B)
<input type="checkbox"/> Saturation (A3)	<input checked="" type="checkbox"/> Drainage Patterns (B10)
<input type="checkbox"/> Water marks (B1)	<input type="checkbox"/> Dry-season Water Table (C2)
<input type="checkbox"/> Sediment Deposits (B2)	<input type="checkbox"/> Saturation Visible on Aerial Imagery (C9)
<input type="checkbox"/> Drift Deposits (B3)	<input type="checkbox"/> Geomorphic Position (D2)
<input type="checkbox"/> Algal Mat or Crust (B4)	<input type="checkbox"/> Shallow Aquitard (D3)
<input type="checkbox"/> Iron Deposits (B5)	<input type="checkbox"/> Frost-heave Hummocks (D7)
<input type="checkbox"/> Surface Soil Cracks (B6)	<input type="checkbox"/> FAC-neutral (D5)
<input type="checkbox"/> Inundation Visible on Aerial Imagery (B7)	<input type="checkbox"/> Other (Explain in Remarks)
Field Observations:	
Surface Water Present? Yes <input type="checkbox"/> No <input checked="" type="checkbox"/> Depth (inches):	Wetland Hydrology Present? Yes <input checked="" type="checkbox"/> No <input type="checkbox"/>
Water Table Present? Yes <input type="checkbox"/> No <input checked="" type="checkbox"/> Depth (inches):	
Saturation Present? Yes <input type="checkbox"/> No <input checked="" type="checkbox"/> Depth (inches): (include capillary fringe)	
Describe Recorded Data (stream gauge, monitoring well, aerial photos, previous inspections), if available:	
Remarks: Soil was damp but not saturated. Primary indicator C3 observed.	

WETLAND DETERMINATION DATA FORM – Western Mountain, Valley Coast Region

Project Site: Viewcrest City/County: Bellingham Sample Date: 06/26/20
 Applicant/Owner: Jones State: WA Sample Point: 04
 Investigator: Van Slyke; Whitehurst Section/Township/Range: 13/37N/02E
 Landform (hillslope, terrace, etc): slope Local Relief (concave, convex, none): Subregion: LRR A
 Soil Map Unit Name: Nati Loam NWL Classification: none
 Are climatic/hydrologic conditions on the site typical of this time of year? Yes No (if no, explain in Remarks)
 Are Vegetation , Soil , or Hydrology significantly disturbed? Are "Normal Circumstances" present? Yes No
 Are Vegetation , Soil , or Hydrology naturally problematic? (If needed, explain any answers in Remarks.)

SUMMARY OF FINDINGS – Attach site map showing sampling point locations, transects, important features, etc.

Hydrophytic Vegetation Present? Yes <input type="checkbox"/> No <input checked="" type="checkbox"/>	Is the Sampled Area within a Wetland? Yes <input type="checkbox"/> No <input checked="" type="checkbox"/>
Hydric Soil Present? Yes <input type="checkbox"/> No <input checked="" type="checkbox"/>	
Wetland Hydrology Present? Yes <input type="checkbox"/> No <input checked="" type="checkbox"/>	
Remarks: Upland island within Wetland B. Positive indicators for all three parameters were not observed at this location.	

VEGETATION

Tree Stratum (Plot size: 30 feet)	Absolute % Cover	Indicator Status	Dominant Species?	Dominance Test worksheet	
<i>Alnus rubra</i>	40	FAC	<input checked="" type="checkbox"/>	Number of Dominant Species that are OBL, FACW, or FAC:	1
<i>Pseudotsuga menziesii</i>	20	FACU	<input checked="" type="checkbox"/>		(A)
		-	<input type="checkbox"/>	Total number of dominant species across all strata:	6
		-	<input type="checkbox"/>		(AB)
Total Cover:	60				
Sapling/Shrub Stratum (Plot size: 15 feet)				Percent of dominant species that or OBL, FACW, FAC:	17
<i>Gaultheria shallon</i>	60	FACU	<input checked="" type="checkbox"/>		(A/AB)
<i>Oemleria cerasiformis</i>	10	FACU	<input type="checkbox"/>		
<i>Vaccinium parvifolium</i>	5	FACU	<input type="checkbox"/>		
		-	<input type="checkbox"/>	Prevalence Index worksheet	
		-	<input type="checkbox"/>		OBL species: x 1=
		-	<input type="checkbox"/>		FACW species: x 2=
		-	<input type="checkbox"/>	FAC species: x 3=	
		-	<input type="checkbox"/>	FACU species: x 4=	
		-	<input type="checkbox"/>	UPL species: x 5=	
Total Cover:	75			Total: (A)	(B)
Herb Stratum (Plot size: 5 feet)				Prevalence Index = B/A =	
<i>Polystichum munitum</i>	20	FACU	<input checked="" type="checkbox"/>	Hydrophytic Vegetation Indicators:	
<i>Rubus ursinus</i>	20	FACU	<input checked="" type="checkbox"/>		<input type="checkbox"/> Dominance Test is > 50%
<i>Geranium robertianum</i>	15	FACU	<input checked="" type="checkbox"/>		<input type="checkbox"/> Prevalence Index is ≤3.0 ¹
		-	<input type="checkbox"/>	<input type="checkbox"/> Morphological Adaptations ¹ (provide supporting data in Remarks or on a separate sheet)	
		-	<input type="checkbox"/>	<input type="checkbox"/> Wetland Non-Vascular Plants ¹	
		-	<input type="checkbox"/>	<input type="checkbox"/> Problematic Hydrophytic Vegetation ¹	
		-	<input type="checkbox"/>	¹ Indicators of hydric soil and wetland hydrology must be present.	
Total Cover:	55				
Woody Vine Stratum (Plot size: 30 feet)					
		-	<input type="checkbox"/>		
		-	<input type="checkbox"/>		
		-	<input type="checkbox"/>		
Total Cover:	0				
% Bare Ground in Herb Stratum: 45					
Remarks: The majority of dominant species observed at this location were not hydrophytic.					Hydrophytic Vegetation Present? Yes <input type="checkbox"/> No <input checked="" type="checkbox"/>

SOIL

Sample Point: 04

Profile Description: (Describe to the depth needed to document the indicator or confirm the absence of indicators.)

Depth (inches)	Soil Color		Redox Features				Texture	Remarks
	Color (moist)	%	Color (moist)	%	Type ¹	Loc ²		
0-8	10YR 3/2	100			-	-	silt loam	
8-16	10YR 3/2	80			-	-	gravelly silt loam	mixed
	10YR 5/2	20			-	-	gravelly silt loam	mixed
					-	-		
					-	-		
					-	-		
					-	-		

¹Type: C=concentration D=depletion RM=reduced matrix ²Location: PL=pore lining RC=root channel M=matrix

Hydric Soil Indicators: (applicable to all LRRs unless otherwise noted)		Indicators for Problematic Hydric Soils³:
<input type="checkbox"/> Histosol (A1) <input type="checkbox"/> Histic Epipedon (A2) <input type="checkbox"/> Black Histic (A3) <input type="checkbox"/> Hydrogen Sulfide (A4) <input type="checkbox"/> Depleted Below Dark Surface (A11) <input type="checkbox"/> Thick Dark Surface (A12) <input type="checkbox"/> Sandy Mucky Mineral (S1) <input type="checkbox"/> Sandy Gleyed Matrix (S4)	<input type="checkbox"/> Sandy Redox (S5) <input type="checkbox"/> Stripped Matrix (S6) <input type="checkbox"/> Loamy Mucky Mineral (F1) (except MLRA 1) <input type="checkbox"/> Loamy Gleyed Matrix (F2) <input type="checkbox"/> Depleted Matrix (F3) <input type="checkbox"/> Redox Dark Surface (F6) <input type="checkbox"/> Depleted Dark Surface (F7) <input type="checkbox"/> Redox Depressions (F8)	
Restrictive Layer (if present): Type: Depth (inches):		Hydric Soil Present? Yes <input type="checkbox"/> No <input checked="" type="checkbox"/>
Remarks: Soil at this location did not meet NRCS hydric soil indicators.		

HYDROLOGY

Wetland hydrology Indicators:		Secondary Indicators (2 or more required)
Primary Indicators (any one indicator is sufficient)		
<input type="checkbox"/> Surface Water (A1) <input type="checkbox"/> High Water Table (A2) <input type="checkbox"/> Saturation (A3) <input type="checkbox"/> Water marks (B1) <input type="checkbox"/> Sediment Deposits (B2) <input type="checkbox"/> Drift Deposits (B3) <input type="checkbox"/> Algal Mat or Crust (B4) <input type="checkbox"/> Iron Deposits (B5) <input type="checkbox"/> Surface Soil Cracks (B6) <input type="checkbox"/> Inundation Visible on Aerial Imagery (B7)	<input type="checkbox"/> Sparsely Vegetated Concave Surface (B8) <input type="checkbox"/> Water-stained Leaves (B9) (except MLRA 1, 2, 4A and 4B) <input type="checkbox"/> Salt Crust (B11) <input type="checkbox"/> Aquatic Invertebrates (B13) <input type="checkbox"/> Hydrogen Sulfide Odor (C1) <input type="checkbox"/> Oxidized Rhizospheres along living roots (C3) <input type="checkbox"/> Presence of Reduced Iron (C4) <input type="checkbox"/> Recent Iron Reduction in Tilled Soils (C6) <input type="checkbox"/> Stunted or Stresses Plants (D1) (LRR A) <input type="checkbox"/> Other (Explain in Remarks)	
Field Observations: Surface Water Present? Yes <input type="checkbox"/> No <input checked="" type="checkbox"/> Depth (inches): Water Table Present? Yes <input type="checkbox"/> No <input checked="" type="checkbox"/> Depth (inches): Saturation Present? Yes <input type="checkbox"/> No <input checked="" type="checkbox"/> Depth (inches): (include capillary fringe)		<input type="checkbox"/> Water-stained (B9) (MLRA 1,2,4A, and 4B) <input type="checkbox"/> Drainage Patterns (B10) <input type="checkbox"/> Dry-season Water Table (C2) <input type="checkbox"/> Saturation Visible on Aerial Imagery (C9) <input type="checkbox"/> Geomorphic Position (D2) <input type="checkbox"/> Shallow Aquitard (D3) <input type="checkbox"/> Frost-heave Hummocks (D7) <input type="checkbox"/> FAC-neutral (D5)
Describe Recorded Data (stream gauge, monitoring well, aerial photos, previous inspections), if available:		
Remarks: Soils were dry, and no indicators of wetland hydrology were observed.		

WETLAND DETERMINATION DATA FORM – Western Mountain, Valley Coast Region

Project Site: Viewcrest City/County: Bellingham Sample Date: 06/26/20
 Applicant/Owner: Jones State: WA Sample Point: 05
 Investigator: Van Slyke; Whitehurst Section/Township/Range: 13/37N/02E
 Landform (hillslope, terrace, etc): slope Local Relief (concave, convex, none) : Subregion: LRR A
 Soil Map Unit Name: Nati Loam NWL Classification: none
 Are climatic/hydrologic conditions on the site typical of this time of year? Yes No (if no, explain in Remarks)
 Are Vegetation , Soil , or Hydrology significantly disturbed? Are "Normal Circumstances" present? Yes No
 Are Vegetation , Soil , or Hydrology naturally problematic? (If needed, explain any answers in Remarks.)

SUMMARY OF FINDINGS – Attach site map showing sampling point locations, transects, important features, etc.

Hydrophytic Vegetation Present? Yes <input checked="" type="checkbox"/> No <input type="checkbox"/>	Is the Sampled Area within a Wetland? Yes <input checked="" type="checkbox"/> No <input type="checkbox"/>
Hydric Soil Present? Yes <input checked="" type="checkbox"/> No <input type="checkbox"/>	
Wetland Hydrology Present? Yes <input checked="" type="checkbox"/> No <input type="checkbox"/>	
Remarks: Wetland C. Positive indicators for all three parameters were observed at this location.	

VEGETATION

Tree Stratum (Plot size: 30 feet)	Absolute % Cover	Indicator Status	Dominant Species?	Dominance Test worksheet	
<i>Alnus rubra</i>	75	FAC	<input checked="" type="checkbox"/>	Number of Dominant Species that are OBL, FACW, or FAC:	3
		-	<input type="checkbox"/>		(A)
		-	<input type="checkbox"/>		
		-	<input type="checkbox"/>	Total number of dominant species across all strata:	3
Total Cover:	75				(AB)
Sapling/Shrub Stratum (Plot size: 15 feet)				Percent of dominant species that or OBL, FACW, FAC:	100
<i>Cornus alba</i>	35	FACW	<input checked="" type="checkbox"/>		
<i>Salix scouleriana</i>	25	FAC	<input checked="" type="checkbox"/>		(A/AB)
		-	<input type="checkbox"/>		
		-	<input type="checkbox"/>		
		-	<input type="checkbox"/>		
Total Cover:	60				
Herb Stratum (Plot size: 5 feet)				FACU species:	x 4=
		-	<input type="checkbox"/>	UPL species:	x 5=
		-	<input type="checkbox"/>	Total:	(A) (B)
		-	<input type="checkbox"/>	Prevalence Index = B/A =	
		-	<input type="checkbox"/>	Hydrophytic Vegetation Indicators:	
		-	<input type="checkbox"/>	<input checked="" type="checkbox"/> Dominance Test is > 50%	
		-	<input type="checkbox"/>	<input type="checkbox"/> Prevalence Index is ≤3.0 ¹	
		-	<input type="checkbox"/>	<input type="checkbox"/> Morphological Adaptations ¹ (provide supporting data in Remarks or on a separate sheet)	
Total Cover:	0			<input type="checkbox"/> Wetland Non-Vascular Plants ¹	
		-	<input type="checkbox"/>	<input type="checkbox"/> Problematic Hydrophytic Vegetation ¹	
		-	<input type="checkbox"/>	¹ Indicators of hydric soil and wetland hydrology must be present.	
Total Cover:	0				
% Bare Ground in Herb Stratum: 100					
Remarks: The majority of dominant species observed at this location were hydrophytic.				Hydrophytic Vegetation Present? Yes <input checked="" type="checkbox"/> No <input type="checkbox"/>	

SOIL

Sample Point: 05

Profile Description: (Describe to the depth needed to document the indicator or confirm the absence of indicators.)

Depth (inches)	Soil Color		Redox Features				Texture	Remarks
	Color (moist)	%	Color (moist)	%	Type ¹	Loc ²		
0-16	10YR 4/1	60	7.5YR 4/6	40	C	M	silt loam with cobble	
					-	-		
					-	-		
					-	-		
					-	-		
					-	-		
					-	-		

¹Type: C=concentration D=depletion RM=reduced matrix ²Location: PL=pore lining RC=root channel M=matrix

Hydric Soil Indicators: (applicable to all LRRs unless otherwise noted)		Indicators for Problematic Hydric Soils³:
<input type="checkbox"/> Histosol (A1)	<input type="checkbox"/> Sandy Redox (S5)	<input type="checkbox"/> 2 cm Muck (A10)
<input type="checkbox"/> Histic Epipedon (A2)	<input type="checkbox"/> Stripped Matrix (S6)	<input type="checkbox"/> Red parent material (TF2)
<input type="checkbox"/> Black Histic (A3)	<input type="checkbox"/> Loamy Mucky Mineral (F1) (except MLRA 1)	<input type="checkbox"/> Very shallow dark surface (TF12)
<input type="checkbox"/> Hydrogen Sulfide (A4)	<input type="checkbox"/> Loamy Gleyed Matrix (F2)	<input type="checkbox"/> Other (Explain in Remarks)
<input type="checkbox"/> Depleted Below Dark Surface (A11)	<input checked="" type="checkbox"/> Depleted Matrix (F3)	
<input type="checkbox"/> Thick Dark Surface (A12)	<input type="checkbox"/> Redox Dark Surface (F6)	
<input type="checkbox"/> Sandy Mucky Mineral (S1)	<input type="checkbox"/> Depleted Dark Surface (F7)	
<input type="checkbox"/> Sandy Gleyed Matrix (S4)	<input type="checkbox"/> Redox Depressions (F8)	
Restrictive Layer (if present):		Hydric Soil Present? Yes <input checked="" type="checkbox"/> No <input type="checkbox"/>
Type:		
Depth (inches):		
Remarks: Soil at this location met NRCS hydric soil indicator F3.		

HYDROLOGY

Wetland hydrology Indicators:	Secondary Indicators (2 or more required)
Primary Indicators (any one indicator is sufficient)	
<input type="checkbox"/> Surface Water (A1)	<input checked="" type="checkbox"/> Water-stained (B9) (MLRA 1,2,4A, and 4B)
<input type="checkbox"/> High Water Table (A2)	<input type="checkbox"/> Drainage Patterns (B10)
<input type="checkbox"/> Saturation (A3)	<input type="checkbox"/> Dry-season Water Table (C2)
<input type="checkbox"/> Water marks (B1)	<input type="checkbox"/> Saturation Visible on Aerial Imagery (C9)
<input type="checkbox"/> Sediment Deposits (B2)	<input type="checkbox"/> Geomorphic Position (D2)
<input type="checkbox"/> Drift Deposits (B3)	<input type="checkbox"/> Shallow Aquitard (D3)
<input type="checkbox"/> Algal Mat or Crust (B4)	<input type="checkbox"/> Frost-heave Hummocks (D7)
<input type="checkbox"/> Iron Deposits (B5)	<input type="checkbox"/> FAC-neutral (D5)
<input type="checkbox"/> Surface Soil Cracks (B6)	
<input type="checkbox"/> Inundation Visible on Aerial Imagery (B7)	
<input type="checkbox"/> Sparsely Vegetated Concave Surface (B8)	
<input type="checkbox"/> Water-stained Leaves (B9) (except MLRA 1, 2, 4A and 4B)	
<input type="checkbox"/> Salt Crust (B11)	
<input type="checkbox"/> Aquatic Invertebrates (B13)	
<input type="checkbox"/> Hydrogen Sulfide Odor (C1)	
<input checked="" type="checkbox"/> Oxidized Rhizospheres along living roots (C3)	
<input type="checkbox"/> Presence of Reduced Iron (C4)	
<input type="checkbox"/> Recent Iron Reduction in Tilled Soils (C6)	
<input type="checkbox"/> Stunted or Stresses Plants (D1) (LRR A)	
<input type="checkbox"/> Other (Explain in Remarks)	
Field Observations:	Wetland Hydrology Present?
Surface Water Present? Yes <input type="checkbox"/> No <input checked="" type="checkbox"/> Depth (inches):	Yes <input checked="" type="checkbox"/> No <input type="checkbox"/>
Water Table Present? Yes <input type="checkbox"/> No <input checked="" type="checkbox"/> Depth (inches):	
Saturation Present? Yes <input type="checkbox"/> No <input checked="" type="checkbox"/> Depth (inches): (include capillary fringe)	
Describe Recorded Data (stream gauge, monitoring well, aerial photos, previous inspections), if available:	
Remarks: Soils were dry during the site visit, but oxidized rhizospheres and water-stained leaves were observed.	

WETLAND DETERMINATION DATA FORM – Western Mountain, Valley Coast Region

Project Site: Viewcrest City/County: Bellingham Sample Date: 08/31/21
 Applicant/Owner: Jones State: WA Sample Point: 100
 Investigator: Van Slyke Section/Township/Range: 13/37N/02E
 Landform (hillslope, terrace, etc): slope Local Relief (concave, convex, none): Subregion: LRR A
 Soil Map Unit Name: Nati Loam NWL Classification: none
 Are climatic/hydrologic conditions on the site typical of this time of year? Yes No (if no, explain in Remarks)
 Are Vegetation , Soil , or Hydrology significantly disturbed? Are "Normal Circumstances" present? Yes No
 Are Vegetation , Soil , or Hydrology naturally problematic? (If needed, explain any answers in Remarks.)

SUMMARY OF FINDINGS – Attach site map showing sampling point locations, transects, important features, etc.

Hydrophytic Vegetation Present? Yes <input checked="" type="checkbox"/> No <input type="checkbox"/>	Is the Sampled Area within a Wetland? Yes <input checked="" type="checkbox"/> No <input type="checkbox"/>
Hydric Soil Present? Yes <input checked="" type="checkbox"/> No <input type="checkbox"/>	
Wetland Hydrology Present? Yes <input checked="" type="checkbox"/> No <input type="checkbox"/>	
Remarks: Wetland D. Positive indicators for all three parameters were observed at this location.	

VEGETATION

Tree Stratum (Plot size: 30 feet)	Absolute % Cover	Indicator Status	Dominant Species?	Dominance Test worksheet	
		-	<input checked="" type="checkbox"/>	Number of Dominant Species that are OBL, FACW, or FAC:	2
		-	<input type="checkbox"/>		(A)
		-	<input type="checkbox"/>		2
Total Cover:	0			Total number of dominant species across all strata:	(AB)
Sapling/Shrub Stratum (Plot size: 15 feet)		-	<input type="checkbox"/>	Percent of dominant species that or OBL, FACW, FAC:	100
		-	<input type="checkbox"/>		(A/AB)
		-	<input type="checkbox"/>		
		-	<input type="checkbox"/>		
Total Cover:	0				
Herb Stratum (Plot size: 5 feet)				Prevalence Index worksheet	
<i>Equisetum telmateia</i>	30	FACW	<input checked="" type="checkbox"/>	OBL species:	x 1=
<i>Lysichiton americanus</i>	25	OBL	<input checked="" type="checkbox"/>	FACW species:	x 2=
<i>Oenanthe sarmentosa</i>	10	OBL	<input type="checkbox"/>	FAC species:	x 3=
		-	<input type="checkbox"/>	FACU species:	x 4=
		-	<input type="checkbox"/>	UPL species:	x 5=
Total Cover:	65			Total: (A)	(B)
		-	<input type="checkbox"/>	Prevalence Index = B/A =	
Woody Vine Stratum (Plot size: 30 feet)				Hydrophytic Vegetation Indicators:	
		-	<input type="checkbox"/>	<input checked="" type="checkbox"/> Dominance Test is > 50%	
		-	<input type="checkbox"/>	<input type="checkbox"/> Prevalence Index is ≤3.0 ¹	
		-	<input type="checkbox"/>	<input type="checkbox"/> Morphological Adaptations ¹ (provide supporting data in Remarks or on a separate sheet)	
		-	<input type="checkbox"/>	<input type="checkbox"/> Wetland Non-Vascular Plants ¹	
		-	<input type="checkbox"/>	<input type="checkbox"/> Problematic Hydrophytic Vegetation ¹	
Total Cover:	0			¹ Indicators of hydric soil and wetland hydrology must be present.	
% Bare Ground in Herb Stratum: 35					
Remarks: The majority of dominant species observed at this location were hydrophytic.				Hydrophytic Vegetation Present?	Yes <input checked="" type="checkbox"/> No <input type="checkbox"/>

SOIL

Sample Point: 100

Profile Description: (Describe to the depth needed to document the indicator or confirm the absence of indicators.)

Depth (inches)	Soil Color		Redox Features				Texture	Remarks
	Color (moist)	%	Color (moist)	%	Type ¹	Loc ²		
0-7	10YR 2/1	100			-	-	Gravelly Sandy Loam	
7-16	Gley 1 4/10GY	85	10YR 3/4	15	C	M	Loamy Clay	
					-	-		
					-	-		
					-	-		
					-	-		
					-	-		

¹Type: C=concentration D=depletion RM=reduced matrix ²Location: PL=pore lining RC=root channel M=matrix

Hydric Soil Indicators: (applicable to all LRRs unless otherwise noted)	Indicators for Problematic Hydric Soils ³ :
<input type="checkbox"/> Histosol (A1) <input type="checkbox"/> Histic Epipedon (A2) <input type="checkbox"/> Black Histic (A3) <input type="checkbox"/> Hydrogen Sulfide (A4) <input checked="" type="checkbox"/> Depleted Below Dark Surface (A11) <input type="checkbox"/> Thick Dark Surface (A12) <input type="checkbox"/> Sandy Mucky Mineral (S1) <input type="checkbox"/> Sandy Gleyed Matrix (S4)	<input type="checkbox"/> Sandy Redox (S5) <input type="checkbox"/> Stripped Matrix (S6) <input type="checkbox"/> Loamy Mucky Mineral (F1) (except MLRA 1) <input type="checkbox"/> Loamy Gleyed Matrix (F2) <input checked="" type="checkbox"/> Depleted Matrix (F3) <input type="checkbox"/> Redox Dark Surface (F6) <input type="checkbox"/> Depleted Dark Surface (F7) <input type="checkbox"/> Redox Depressions (F8)
	<input type="checkbox"/> 2 cm Muck (A10) <input type="checkbox"/> Red parent material (TF2) <input type="checkbox"/> Very shallow dark surface (TF12) <input type="checkbox"/> Other (Explain in Remarks)
³ Indicators of hydrophytic vegetation and wetland hydrology must be present.	
Restrictive Layer (if present):	Hydric Soil Present? Yes <input checked="" type="checkbox"/> No <input type="checkbox"/>
Type: loamy clay Depth (inches): 7	
Remarks: Soil at this location met NRCS hydric soil indicators A11 and F3.	

HYDROLOGY

Wetland hydrology Indicators:	Secondary Indicators (2 or more required)
Primary Indicators (any one indicator is sufficient) <input type="checkbox"/> Surface Water (A1) <input type="checkbox"/> High Water Table (A2) <input checked="" type="checkbox"/> Saturation (A3) <input type="checkbox"/> Water marks (B1) <input type="checkbox"/> Sediment Deposits (B2) <input type="checkbox"/> Drift Deposits (B3) <input type="checkbox"/> Algal Mat or Crust (B4) <input type="checkbox"/> Iron Deposits (B5) <input type="checkbox"/> Surface Soil Cracks (B6) <input type="checkbox"/> Inundation Visible on Aerial Imagery (B7)	<input type="checkbox"/> Sparsely Vegetated Concave Surface (B8) <input type="checkbox"/> Water-stained Leaves (B9) (except MLRA 1, 2, 4A and 4B) <input type="checkbox"/> Salt Crust (B11) <input type="checkbox"/> Aquatic Invertebrates (B13) <input type="checkbox"/> Hydrogen Sulfide Odor (C1) <input type="checkbox"/> Oxidized Rhizospheres along living roots (C3) <input type="checkbox"/> Presence of Reduced Iron (C4) <input type="checkbox"/> Recent Iron Reduction in Tilled Soils (C6) <input type="checkbox"/> Stunted or Stresses Plants (D1) (LRR A) <input type="checkbox"/> Other (Explain in Remarks)
<input type="checkbox"/> Water-stained (B9) (MLRA 1, 2, 4A, and 4B) <input type="checkbox"/> Drainage Patterns (B10) <input type="checkbox"/> Dry-season Water Table (C2) <input type="checkbox"/> Saturation Visible on Aerial Imagery (C9) <input type="checkbox"/> Geomorphic Position (D2) <input type="checkbox"/> Shallow Aquitard (D3) <input type="checkbox"/> Frost-heave Hummocks (D7) <input type="checkbox"/> FAC-neutral (D5)	
Field Observations:	Wetland Hydrology Present? Yes <input checked="" type="checkbox"/> No <input type="checkbox"/>
Surface Water Present? Yes <input checked="" type="checkbox"/> No <input type="checkbox"/> Depth (inches): 0-7	
Water Table Present? Yes <input type="checkbox"/> No <input checked="" type="checkbox"/> Depth (inches):	
Saturation Present? Yes <input type="checkbox"/> No <input checked="" type="checkbox"/> Depth (inches): (include capillary fringe)	
Describe Recorded Data (stream gauge, monitoring well, aerial photos, previous inspections), if available:	
Remarks: Indicators of wetland hydrology were observed at this location.	

WETLAND DETERMINATION DATA FORM – Western Mountain, Valley Coast Region

Project Site: Viewcrest City/County: Bellingham Sample Date: 06/26/20
 Applicant/Owner: Jones State: WA Sample Point: 101
 Investigator: Van Slyke; Whitehurst Section/Township/Range: 13/37N/02E
 Landform (hillslope, terrace, etc): slope Local Relief (concave, convex, none) : Subregion: LRR A
 Soil Map Unit Name: Nati Loam NWI Classification: none
 Are climatic/hydrologic conditions on the site typical of this time of year? Yes No (if no, explain in Remarks)
 Are Vegetation , Soil , or Hydrology significantly disturbed? Are "Normal Circumstances" present? Yes No
 Are Vegetation , Soil , or Hydrology naturally problematic? (If needed, explain any answers in Remarks.)

SUMMARY OF FINDINGS – Attach site map showing sampling point locations, transects, important features, etc.

Hydrophytic Vegetation Present? Yes <input type="checkbox"/> No <input checked="" type="checkbox"/>	Is the Sampled Area within a Wetland? Yes <input type="checkbox"/> No <input checked="" type="checkbox"/>
Hydric Soil Present? Yes <input type="checkbox"/> No <input checked="" type="checkbox"/>	
Wetland Hydrology Present? Yes <input type="checkbox"/> No <input checked="" type="checkbox"/>	
Remarks: Upland adjacent to Wetland D. Positive indicators for all three parameters were not observed at this location.	

VEGETATION

Tree Stratum (Plot size: 30 feet)	Absolute % Cover	Indicator Status	Dominant Species?	Dominance Test worksheet	
<i>Pseudotsuga menziesii</i>	95	FACU	<input checked="" type="checkbox"/>	Number of Dominant Species that are OBL, FACW, or FAC:	0
		-	<input type="checkbox"/>		(A)
		-	<input type="checkbox"/>		4
Total Cover:	95			Total number of dominant species across all strata:	(AB)
Sapling/Shrub Stratum (Plot size: 15 feet)				Percent of dominant species that are OBL, FACW, FAC:	0
<i>Rosa gymnocarpa</i>	15	FACU	<input checked="" type="checkbox"/>		(A/AB)
<i>Symphoricarpos albus</i>	5	FACU	<input checked="" type="checkbox"/>		
		-	<input type="checkbox"/>		
		-	<input type="checkbox"/>		
Total Cover:	20				
Herb Stratum (Plot size: 5 feet)					
<i>Gaultheria shallon</i>	95	FACU	<input checked="" type="checkbox"/>	Prevalence Index worksheet	
<i>Rubus ursinus</i>	5	FACU	<input type="checkbox"/>	OBL species: x 1=	
<i>Pteridium aquilinum</i>	5	FACU	<input type="checkbox"/>	FACW species: x 2=	
		-	<input type="checkbox"/>	FAC species: x 3=	
		-	<input type="checkbox"/>	FACU species: x 4=	
Total Cover:	105			UPL species: x 5=	
		-	<input type="checkbox"/>	Total: (A) (B)	
		-	<input type="checkbox"/>	Prevalence Index = B/A =	
		-	<input type="checkbox"/>	Hydrophytic Vegetation Indicators:	
		-	<input type="checkbox"/>	<input type="checkbox"/> Dominance Test is > 50%	
		-	<input type="checkbox"/>	<input type="checkbox"/> Prevalence Index is ≤3.0 ¹	
		-	<input type="checkbox"/>	<input type="checkbox"/> Morphological Adaptations ¹ (provide supporting data in Remarks or on a separate sheet)	
Total Cover:	0			<input type="checkbox"/> Wetland Non-Vascular Plants ¹	
		-	<input type="checkbox"/>	<input type="checkbox"/> Problematic Hydrophytic Vegetation ¹	
% Bare Ground in Herb Stratum: 0				¹ Indicators of hydric soil and wetland hydrology must be present.	
Remarks: The dominant species observed at this location were not hydrophytic.				Hydrophytic Vegetation Present? Yes <input type="checkbox"/> No <input checked="" type="checkbox"/>	

SOIL

Sample Point: 101

Profile Description: (Describe to the depth needed to document the indicator or confirm the absence of indicators.)

Depth (inches)	Soil Color		Redox Features				Texture	Remarks
	Color (moist)	%	Color (moist)	%	Type ¹	Loc ²		
0-3	7.5YR 2.5/2	100			-	-	Sandy Loam	
3-16	10YR 4/3	100			-	-	Silt Loam	
					-	-		
					-	-		
					-	-		
					-	-		
					-	-		
					-	-		

¹Type: C=concentration D=depletion RM=reduced matrix ²Location: PL=pore lining RC=root channel M=matrix

Hydric Soil Indicators: (applicable to all LRRs unless otherwise noted)		Indicators for Problematic Hydric Soils³:
<input type="checkbox"/> Histosol (A1)	<input type="checkbox"/> Sandy Redox (S5)	<input type="checkbox"/> 2 cm Muck (A10)
<input type="checkbox"/> Histic Epipedon (A2)	<input type="checkbox"/> Stripped Matrix (S6)	<input type="checkbox"/> Red parent material (TF2)
<input type="checkbox"/> Black Histic (A3)	<input type="checkbox"/> Loamy Mucky Mineral (F1) (except MLRA 1)	<input type="checkbox"/> Very shallow dark surface (TF12)
<input type="checkbox"/> Hydrogen Sulfide (A4)	<input type="checkbox"/> Loamy Gleyed Matrix (F2)	<input type="checkbox"/> Other (Explain in Remarks)
<input type="checkbox"/> Depleted Below Dark Surface (A11)	<input type="checkbox"/> Depleted Matrix (F3)	
<input type="checkbox"/> Thick Dark Surface (A12)	<input type="checkbox"/> Redox Dark Surface (F6)	
<input type="checkbox"/> Sandy Mucky Mineral (S1)	<input type="checkbox"/> Depleted Dark Surface (F7)	
<input type="checkbox"/> Sandy Gleyed Matrix (S4)	<input type="checkbox"/> Redox Depressions (F8)	
Restrictive Layer (if present):		Hydric Soil Present? Yes <input type="checkbox"/> No <input checked="" type="checkbox"/>
Type:		
Depth (inches):		
Remarks: Soil at this location did not meet NRCS hydric soil indicators.		

HYDROLOGY

Wetland hydrology Indicators:	Secondary Indicators (2 or more required)
Primary Indicators (any one indicator is sufficient)	
<input type="checkbox"/> Surface Water (A1)	<input type="checkbox"/> Sparsely Vegetated Concave Surface (B8)
<input type="checkbox"/> High Water Table (A2)	<input type="checkbox"/> Water-stained Leaves (B9) (except MLRA 1, 2, 4A and 4B)
<input type="checkbox"/> Saturation (A3)	<input type="checkbox"/> Drainage Patterns (B10)
<input type="checkbox"/> Water marks (B1)	<input type="checkbox"/> Dry-season Water Table (C2)
<input type="checkbox"/> Sediment Deposits (B2)	<input type="checkbox"/> Saturation Visible on Aerial Imagery (C9)
<input type="checkbox"/> Drift Deposits (B3)	<input type="checkbox"/> Geomorphic Position (D2)
<input type="checkbox"/> Algal Mat or Crust (B4)	<input type="checkbox"/> Shallow Aquitard (D3)
<input type="checkbox"/> Iron Deposits (B5)	<input type="checkbox"/> Frost-heave Hummocks (D7)
<input type="checkbox"/> Surface Soil Cracks (B6)	<input type="checkbox"/> FAC-neutral (D5)
<input type="checkbox"/> Inundation Visible on Aerial Imagery (B7)	<input type="checkbox"/> Other (Explain in Remarks)
Field Observations:	Wetland Hydrology Present?
Surface Water Present? Yes <input type="checkbox"/> No <input checked="" type="checkbox"/> Depth (inches):	Yes <input type="checkbox"/> No <input checked="" type="checkbox"/>
Water Table Present? Yes <input type="checkbox"/> No <input checked="" type="checkbox"/> Depth (inches):	
Saturation Present? Yes <input type="checkbox"/> No <input checked="" type="checkbox"/> Depth (inches): (include capillary fringe)	
Describe Recorded Data (stream gauge, monitoring well, aerial photos, previous inspections), if available:	
Remarks: Indicators of hydrology were not observed at this location.	

WETLAND DETERMINATION DATA FORM – Western Mountain, Valley Coast Region

Project Site: Viewcrest City/County: Bellingham Sample Date: 06/26/20
 Applicant/Owner: Jones State: WA Sample Point: 102
 Investigator: Van Slyke; Whitehurst Section/Township/Range: 13/37N/02E
 Landform (hillslope, terrace, etc): slope Local Relief (concave, convex, none): Subregion: LRR A
 Soil Map Unit Name: Nati Loam NWL Classification: none
 Are climatic/hydrologic conditions on the site typical of this time of year? Yes No (if no, explain in Remarks)
 Are Vegetation , Soil , or Hydrology significantly disturbed? Are "Normal Circumstances" present? Yes No
 Are Vegetation , Soil , or Hydrology naturally problematic? (If needed, explain any answers in Remarks.)

SUMMARY OF FINDINGS – Attach site map showing sampling point locations, transects, important features, etc.

Hydrophytic Vegetation Present? Yes <input checked="" type="checkbox"/> No <input type="checkbox"/>	Is the Sampled Area within a Wetland? Yes <input type="checkbox"/> No <input checked="" type="checkbox"/>
Hydric Soil Present? Yes <input type="checkbox"/> No <input checked="" type="checkbox"/>	
Wetland Hydrology Present? Yes <input checked="" type="checkbox"/> No <input type="checkbox"/>	
Remarks: Seep. Positive indicators for hydric soil were not observed at this location and therefore do not meet wetland criteria.	

VEGETATION

Tree Stratum (Plot size: 30 feet)	Absolute % Cover	Indicator Status	Dominant Species?	Dominance Test worksheet	
		-	<input type="checkbox"/>	Number of Dominant Species that are OBL, FACW, or FAC:	4
		-	<input type="checkbox"/>		(A)
		-	<input type="checkbox"/>		6
Total Cover:	0			Total number of dominant species across all strata:	(AB)
Sapling/Shrub Stratum (Plot size: 15 feet)				Percent of dominant species that are OBL, FACW, FAC:	66
<i>Lonicera involucrata</i>	25	FAC	<input checked="" type="checkbox"/>		
<i>Corylus cornuta</i>	20	FACU	<input checked="" type="checkbox"/>		(A/AB)
<i>Salix scouleriana</i>	20	FAC	<input checked="" type="checkbox"/>		
<i>Symphoricarpos albus</i>	15	FACU	<input type="checkbox"/>		
Total Cover:	80				
Herb Stratum (Plot size: 5 feet)				Prevalence Index worksheet	
<i>Athyrium filix-femina</i>	30	FAC	<input checked="" type="checkbox"/>	OBL species: x 1=	
<i>Gaultheria shallon</i>	15	FACU	<input checked="" type="checkbox"/>	FACW species: x 2=	
<i>Geum macrophyllum</i>	5	FAC	<input type="checkbox"/>	FAC species: x 3=	
<i>Geranium robertianum</i>	5	FACU	<input type="checkbox"/>	FACU species: x 4=	
Total Cover:	55			UPL species: x 5=	(B)
				Total: (A)	(B)
				Prevalence Index = B/A =	
Woody Vine Stratum (Plot size: 30 feet)				Hydrophytic Vegetation Indicators:	
<i>Rubus armeniacus</i>	15	FAC	<input checked="" type="checkbox"/>	<input checked="" type="checkbox"/> Dominance Test is > 50%	
		-	<input type="checkbox"/>	<input type="checkbox"/> Prevalence Index is ≤3.0 ¹	
		-	<input type="checkbox"/>	<input type="checkbox"/> Morphological Adaptations ¹ (provide supporting data in Remarks or on a separate sheet)	
Total Cover:	15			<input type="checkbox"/> Wetland Non-Vascular Plants ¹	
				<input type="checkbox"/> Problematic Hydrophytic Vegetation ¹	
				¹ Indicators of hydric soil and wetland hydrology must be present.	
% Bare Ground in Herb Stratum: 45					
Remarks: The majority of dominant species observed at this location were hydrophytic.				Hydrophytic Vegetation Present? Yes <input checked="" type="checkbox"/> No <input type="checkbox"/>	

SOIL

Sample Point: 102

Profile Description: (Describe to the depth needed to document the indicator or confirm the absence of indicators.)

Depth (inches)	Soil Color		Redox Features				Texture	Remarks
	Color (moist)	%	Color (moist)	%	Type ¹	Loc ²		
0-16	10YR 3/2	100			-	-	Silt Loam	Cobble
16-20	10YR 4/2	40	10YR 4/4	10	C	M	Sandy Silt Loam	
	10YR 3/2	50			-	-	Silt Loam	
					-	-		
					-	-		
					-	-		
					-	-		
					-	-		

¹Type: C=concentration D=depletion RM=reduced matrix ²Location: PL=pore lining RC=root channel M=matrix

Hydric Soil Indicators: (applicable to all LRRs unless otherwise noted)		Indicators for Problematic Hydric Soils³:
<input type="checkbox"/> Histosol (A1)	<input type="checkbox"/> Sandy Redox (S5)	<input type="checkbox"/> 2 cm Muck (A10)
<input type="checkbox"/> Histic Epipedon (A2)	<input type="checkbox"/> Stripped Matrix (S6)	<input type="checkbox"/> Red parent material (TF2)
<input type="checkbox"/> Black Histic (A3)	<input type="checkbox"/> Loamy Mucky Mineral (F1) (except MLRA 1)	<input type="checkbox"/> Very shallow dark surface (TF12)
<input type="checkbox"/> Hydrogen Sulfide (A4)	<input type="checkbox"/> Loamy Gleyed Matrix (F2)	<input type="checkbox"/> Other (Explain in Remarks)
<input type="checkbox"/> Depleted Below Dark Surface (A11)	<input type="checkbox"/> Depleted Matrix (F3)	
<input type="checkbox"/> Thick Dark Surface (A12)	<input type="checkbox"/> Redox Dark Surface (F6)	
<input type="checkbox"/> Sandy Mucky Mineral (S1)	<input type="checkbox"/> Depleted Dark Surface (F7)	
<input type="checkbox"/> Sandy Gleyed Matrix (S4)	<input type="checkbox"/> Redox Depressions (F8)	
Restrictive Layer (if present):		Hydric Soil Present? Yes <input type="checkbox"/> No <input checked="" type="checkbox"/>
Type:		
Depth (inches):		
Remarks: Soil at this location did not meet NRCS hydric soil indicators.		

HYDROLOGY

Wetland hydrology Indicators:	Secondary Indicators (2 or more required)
Primary Indicators (any one indicator is sufficient)	
<input type="checkbox"/> Surface Water (A1)	<input type="checkbox"/> Sparsely Vegetated Concave Surface (B8)
<input type="checkbox"/> High Water Table (A2)	<input type="checkbox"/> Water-stained Leaves (B9) (except MLRA 1, 2, 4A and 4B)
<input type="checkbox"/> Saturation (A3)	<input type="checkbox"/> Drainage Patterns (B10)
<input type="checkbox"/> Water marks (B1)	<input type="checkbox"/> Salt Crust (B11)
<input type="checkbox"/> Sediment Deposits (B2)	<input type="checkbox"/> Aquatic Invertebrates (B13)
<input type="checkbox"/> Drift Deposits (B3)	<input type="checkbox"/> Hydrogen Sulfide Odor (C1)
<input type="checkbox"/> Algal Mat or Crust (B4)	<input type="checkbox"/> Oxidized Rhizospheres along living roots (C3)
<input type="checkbox"/> Iron Deposits (B5)	<input type="checkbox"/> Presence of Reduced Iron (C4)
<input type="checkbox"/> Surface Soil Cracks (B6)	<input type="checkbox"/> Recent Iron Reduction in Tilled Soils (C6)
<input type="checkbox"/> Inundation Visible on Aerial Imagery (B7)	<input type="checkbox"/> Stunted or Stresses Plants (D1) (LRR A)
	<input type="checkbox"/> Other (Explain in Remarks)
Field Observations:	
Surface Water Present? Yes <input type="checkbox"/> No <input checked="" type="checkbox"/> Depth (inches):	Wetland Hydrology Present? Yes <input checked="" type="checkbox"/> No <input type="checkbox"/>
Water Table Present? Yes <input type="checkbox"/> No <input checked="" type="checkbox"/> Depth (inches):	
Saturation Present? Yes <input type="checkbox"/> No <input checked="" type="checkbox"/> Depth (inches): (include capillary fringe)	
Describe Recorded Data (stream gauge, monitoring well, aerial photos, previous inspections), if available:	
Remarks: Soils were dry during the August 2021 site visit but were saturated during the June 2020 visit.	

Wetland name or number Wetland A

RATING SUMMARY – Western Washington

Name of wetland (or ID #): Viewcrest Wetland A Date of site visit: 6/26/20
 Rated by C. Van Slyke Trained by Ecology? Yes No Date of training 2014

HGM Class used for rating Slope Wetland has multiple HGM classes? Yes No

NOTE: Form is not complete without the figures requested (figures can be combined).

Source of base aerial photo/map Whatcom County 2017

OVERALL WETLAND CATEGORY IV (based on functions or special characteristics)

1. Category of wetland based on FUNCTIONS

Category I – Total score = 23 - 27

Category II – Total score = 20 - 22

Category III – Total score = 16 - 19

Category IV – Total score = 9 - 15

FUNCTION	Improving		Hydrologic	Habitat
	Water Quality			
Site Potential	HO M O L ⊕	HO M ⊕ LO	HO MO LO	HO MO LO ⊕
Landscape Potential	HO M ⊕ LO	HO M ⊕ LO	HO MO LO	HO MO LO ⊕
Value	HO M O L ⊕	HO M O L ⊕	HO MO LO	HO MO LO
Score Based on Ratings	4	5	4	13

Score for each function based on three ratings (order of ratings is not important)

- 9 = H,H,H
- 8 = H,H,M
- 7 = H,H,L
- 6 = H,M,M
- 5 = H,L,L
- 4 = M,M,L
- 3 = L,L,L

2. Category based on SPECIAL CHARACTERISTICS of wetland

CHARACTERISTIC	CATEGORY
Estuarine	I II
Wetland of High Conservation Value	I
Bog	I
Mature Forest	I
Old Growth Forest	I
Coastal Lagoon	I II
Interdunal	I II III IV
None of the above	<input checked="" type="checkbox"/>

Wetland Rating System for Western WA: 2014 Update
 Rating Form – Effective January 1, 2015

Wetland name or number Wetland A

Maps and figures required to answer questions correctly for Western Washington

Depressional Wetlands

Map of:	To answer questions:	Figure #
Cowardin plant classes	D 1.3, H 1.1, H 1.4	
Hydroperiods	D 1.4, H 1.2	
Location of outlet (can be added to map of hydroperiods)	D 1.1, D 4.1	
Boundary of area within 150 ft of the wetland (can be added to another figure)	D 2.2, D 5.2	
Map of the contributing basin	D 4.3, D 5.3	
1 km Polygon: Area that extends 1 km from entire wetland edge - including polygons for accessible habitat and undisturbed habitat	H 2.1, H 2.2, H 2.3	
Screen capture of map of 303(d) listed waters in basin (from Ecology website)	D 3.1, D 3.2	
Screen capture of list of TMDLs for WRIA in which unit is found (from web)	D 3.3	

Riverine Wetlands

Map of:	To answer questions:	Figure #
Cowardin plant classes	H 1.1, H 1.4	
Hydroperiods	H 1.2	
Ponded depressions	R 1.1	
Boundary of area within 150 ft of the wetland (can be added to another figure)	R 2.4	
Plant cover of trees, shrubs, and herbaceous plants	R 1.2, R 4.2	
Width of unit vs. width of stream (can be added to another figure)	R 4.1	
Map of the contributing basin	R 2.2, R 2.3, R 5.2	
1 km Polygon: Area that extends 1 km from entire wetland edge - including polygons for accessible habitat and undisturbed habitat	H 2.1, H 2.2, H 2.3	
Screen capture of map of 303(d) listed waters in basin (from Ecology website)	R 3.1	
Screen capture of list of TMDLs for WRIA in which unit is found (from web)	R 3.2, R 3.3	

Lake Fringe Wetlands

Map of:	To answer questions:	Figure #
Cowardin plant classes	L 1.1, L 4.1, H 1.1, H 1.4	
Plant cover of trees, shrubs, and herbaceous plants	L 1.2	
Boundary of area within 150 ft of the wetland (can be added to another figure)	L 2.2	
1 km Polygon: Area that extends 1 km from entire wetland edge - including polygons for accessible habitat and undisturbed habitat	H 2.1, H 2.2, H 2.3	
Screen capture of map of 303(d) listed waters in basin (from Ecology website)	L 3.1, L 3.2	
Screen capture of list of TMDLs for WRIA in which unit is found (from web)	L 3.3	

Slope Wetlands

Map of:	To answer questions:	Figure #
Cowardin plant classes	H 1.1, H 1.4	A
Hydroperiods	H 1.2	B
Plant cover of dense trees, shrubs, and herbaceous plants	S 1.3	A
Plant cover of dense, rigid trees, shrubs, and herbaceous plants (can be added to figure above)	S 4.1	A
Boundary of 150 ft buffer (can be added to another figure)	S 2.1, S 5.1	B
1 km Polygon: Area that extends 1 km from entire wetland edge - including polygons for accessible habitat and undisturbed habitat	H 2.1, H 2.2, H 2.3	C
Screen capture of map of 303(d) listed waters in basin (from Ecology website)	S 3.1, S 3.2	D
Screen capture of list of TMDLs for WRIA in which unit is found (from web)	S 3.3	D

Wetland Rating System for Western WA: 2014 Update
 Rating Form – Effective January 1, 2015

Wetland name or number Wetland A

HGM Classification of Wetlands in Western Washington

For questions 1-7, the criteria described must apply to the entire unit being rated.

If the hydrologic criteria listed in each question do not apply to the entire unit being rated, you probably have a unit with multiple HGM classes. In this case, identify which hydrologic criteria in questions 1-7 apply, and go to Question 8.

- Are the water levels in the entire unit usually controlled by tides except during floods?
NO - go to 2
YES - the wetland class is **Tidal Fringe** - go to 1.1
1.1 Is the salinity of the water during periods of annual low flow below 0.5 ppt (parts per thousand)?
NO - Saltwater Tidal Fringe (Estuarine)
YES - Freshwater Tidal Fringe
If your wetland can be classified as a Freshwater Tidal Fringe use the forms for Riverine wetlands. If it is Saltwater Tidal Fringe it is an Estuarine wetland and is not scored. This method cannot be used to score functions for estuarine wetlands.
- The entire wetland unit is flat and precipitation is the only source (>90%) of water to it. Groundwater and surface water runoff are NOT sources of water to the unit.
NO - go to 3
YES - The wetland class is **Flats**
If your wetland can be classified as a Flats wetland, use the form for Depressional wetlands.
- Does the entire wetland unit **meet all** of the following criteria?
___ The vegetated part of the wetland is on the shores of a body of permanent open water (without any plants on the surface at any time of the year) at least 20 ac (8 ha) in size;
___ At least 30% of the open water area is deeper than 6.6 ft (2 m).
NO - go to 4
YES - The wetland class is **Lake Fringe** (Lacustrine Fringe)
- Does the entire wetland unit **meet all** of the following criteria?
 The wetland is on a slope (*slope can be very gradual*).
 The water flows through the wetland in one direction (unidirectional) and usually comes from seeps. It may flow subsurface, as sheetflow, or in a swale without distinct banks.
 The water leaves the wetland **without being impounded**.
NO - go to 5
YES - The wetland class is **Slope**
NOTE: Surface water does not pond in these type of wetlands except occasionally in very small and shallow depressions or behind hummocks (depressions are usually <3 ft diameter and less than 1 ft deep).
- Does the entire wetland unit **meet all** of the following criteria?
___ The unit is in a valley, or stream channel, where it gets inundated by overbank flooding from that stream or river,
___ The overbank flooding occurs at least once every 2 years.

Wetland name or number Wetland A

NO - go to 6

NOTE: The Riverine unit can contain depressions that are filled with water when the river is not flooding

YES - The wetland class is **Riverine**

- Is the entire wetland unit in a topographic depression in which water ponds, or is saturated to the surface, at some time during the year? *This means that any outlet, if present, is higher than the interior of the wetland.*

NO - go to 7

YES - The wetland class is **Depressional**

- Is the entire wetland unit located in a very flat area with no obvious depression and no overbank flooding? The unit does not pond surface water more than a few inches. The unit seems to be maintained by high groundwater in the area. The wetland may be ditched, but has no obvious natural outlet.

NO - go to 8

YES - The wetland class is **Depressional**

- Your wetland unit seems to be difficult to classify and probably contains several different HGM classes. For example, seeps at the base of a slope may grade into a riverine floodplain, or a small stream within a Depressional wetland has a zone of flooding along its sides. **GO BACK AND IDENTIFY WHICH OF THE HYDROLOGIC REGIMES DESCRIBED IN QUESTIONS 1-7 APPLY TO DIFFERENT AREAS IN THE UNIT** (make a rough sketch to help you decide). Use the following table to identify the appropriate class to use for the rating system if you have several HGM classes present within the wetland unit being scored.

NOTE: Use this table only if the class that is recommended in the second column represents 10% or more of the total area of the wetland unit being rated. If the area of the HGM class listed in column 2 is less than 10% of the unit; classify the wetland using the class that represents more than 90% of the total area.

HGM classes within the wetland unit being rated	HGM class to use in rating
Slope + Riverine	Riverine
Slope + Depressional	Depressional
Slope + Lake Fringe	Lake Fringe
Depressional + Riverine along stream within boundary of depression	Depressional
Depressional + Lake Fringe	Depressional
Riverine + Lake Fringe	Riverine
Salt Water Tidal Fringe and any other class of freshwater wetland	Treat as ESTUARINE

If you are still unable to determine which of the above criteria apply to your wetland, or if you have more than 2 HGM classes within a wetland boundary, classify the wetland as Depressional for the rating.

Wetland name or number: Wetland A

SLOPE WETLANDS	
Water Quality Functions - Indicators that the site functions to improve water quality	
S 1.0. Does the site have the potential to improve water quality?	0
S 1.1. Characteristics of the average slope of the wetland: (a 1% slope has a 1 ft vertical drop in elevation for every 100 ft of horizontal distance) Slope is 1% or less Slope is > 1%-2% Slope is > 2%-5% Slope is greater than 5%	points = 3 points = 2 points = 1 points = 0
S 1.2. The soil 2 in. below the surface (or duff layer) is true clay or true organic (use NRCS definitions): Yes = 3 No = 0	0
S 1.3. Characteristics of the plants in the wetland that trap sediments and pollutants: Choose the points appropriate for the description that best fits the plants in the wetland. Dense means you have trouble seeing the soil surface (>75% cover), and uncut means not grazed or mowed and plants are higher than 6 in. Dense, uncut, herbaceous plants > 90% of the wetland area Dense, uncut, herbaceous plants > 1/2 of area Dense, woody, plants > 1/2 of area Dense, uncut, herbaceous plants > 1/4 of area Does not meet any of the criteria above for plants	points = 6 points = 3 points = 2 points = 1 points = 0
Total for S 1	3
Rating of Site Potential If score is: <u>12</u> = H <u>6-11</u> = M <u>0-5</u> = L	

S 2.0. Does the landscape have the potential to support the water quality function of the site?	1
S 2.1. Is > 10% of the area within 150 ft on the uphill side of the wetland in land uses that generate pollutants? Yes = 1 No = 0	1
S 2.2. Are there other sources of pollutants coming into the wetland that are not listed in question S 2.1? Other sources: _____ Yes = 1 No = 0	0
Total for S 2	1
Rating of Landscape Potential If score is: <u>1-2</u> = M <u>0</u> = L	

S 3.0. Is the water quality improvement provided by the site valuable to society?	0
S 3.1. Does the wetland discharge directly (i.e., within 1 mi) to a stream, river, lake, or marine water that is on the 303(d) list? Yes = 1 No = 0	0
S 3.2. Is the wetland in a basin or sub-basin where water quality is an issue? At least one aquatic resource in the basin is on the 303(d) list. Yes = 1 No = 0	0
S 3.3. Has the site been identified in a watershed or local plan as important for maintaining water quality? Answer YES if there is a TMDL for the basin in which unit is found. Yes = 2 No = 0	0
Total for S 3	0
Rating of Value If score is: <u>2-4</u> = H <u>1</u> = M <u>0</u> = L	

Record the rating on the first page

Wetland name or number: Wetland A

SLOPE WETLANDS	
Hydrologic Functions - Indicators that the site functions to reduce flooding and stream erosion	
S 4.0. Does the site have the potential to reduce flooding and stream erosion?	1
S 4.1. Characteristics of plants that reduce the velocity of surface flows during storms: Choose the points appropriate for the description that best fits conditions in the wetland. Stems of plants should be thick enough (usually > 1/8 in), or dense enough, to remain erect during surface flows. Dense, uncut, rigid plants cover > 90% of the area of the wetland All other conditions	points = 1 points = 0
Rating of Site Potential If score is: <u>1</u> = M <u>0</u> = L	



S 5.0. Does the landscape have the potential to support the hydrologic functions of the site?	1
S 5.1. Is more than 25% of the area within 150 ft upslope of wetland in land uses or cover that generate excess surface runoff? Yes = 1 No = 0	1
Rating of Landscape Potential If score is: <u>1</u> = M <u>0</u> = L	

S 6.0. Are the hydrologic functions provided by the site valuable to society?	0
S 6.1. Distance to the nearest areas downstream that have flooding problems: The sub-basin immediately down-gradient of site has flooding problems that result in damage to human or natural resources (e.g., houses or salmon redds) Surface flooding problems are in a sub-basin farther down-gradient No flooding problems anywhere downstream	points = 2 points = 1 points = 0
S 6.2. Has the site been identified as important for flood storage or flood conveyance in a regional flood control plan? Yes = 2 No = 0	0
Total for S 6	0
Rating of Value If score is: <u>2-4</u> = H <u>1</u> = M <u>0</u> = L	

Record the rating on the first page

NOTES and FIELD OBSERVATIONS:

Wetland name or number: Wetland A

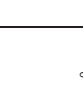
<p>These questions apply to wetlands of all HGM classes.</p> <p>HABITAT FUNCTIONS - Indicators that site functions to provide important habitat</p>	
H 1.0. Does the site have the potential to provide habitat?	
H 1.1. Structure of plant community. Indicators are Cowardin classes and strata within the Forested class. Check the Cowardin plant classes in the wetland. Up to 10 patches may be combined for each class to meet the threshold of % ac or more than 10% of the unit if it is smaller than 2.5 ac. Add the number of structures checked.	<p>1</p> <p>___ Aquatic bed</p> <p>___ Emergent</p> <p>___ Scrub-shrub (areas where shrubs have > 30% cover)</p> <p>___ Forested (areas where trees have > 30% cover)</p> <p>___ If the unit has a Forested class, check if:</p> <p>___ The Forested class has 3 out of 5 strata (canopy, sub-canopy, shrubs, herbaceous, moss/ground-cover) that each cover 20% within the Forested polygon</p>
H 1.2. Hydroperiods	<p>Check the types of water regimes (hydroperiods) present within the wetland. The water regime has to cover more than 10% of the wetland or % ac to count (see text for descriptions of hydroperiods).</p> <p>___ Permanently flooded or inundated</p> <p>___ Seasonally flooded or inundated</p> <p>___ Occasionally flooded or inundated</p> <p>___ Saturated only</p> <p>___ Permanently flowing stream or river in, or adjacent to, the wetland</p> <p>___ Seasonally flowing stream in, or adjacent to, the wetland</p> <p>___ Lake Fringe wetland</p> <p>___ Freshwater tidal wetland</p>
H 1.3. Richness of plant species	<p>Count the number of plant species in the wetland that cover at least 10 ft.².</p> <p>Different patches of the same species can be combined to meet the size threshold and you do not have to name the species. Do not include Eurasian milfoil, reed canarygrass, purple loosestrife, Canadian thistle</p> <p>If you counted: > 19 species points = 2</p> <p>5 - 19 species points = 1</p> <p>< 5 species points = 0</p>
H 1.4. Interspersion of habitats	<p>Decide from the diagrams below whether interspersion among Cowardin plants classes (described in H 1.1), or the classes and unvegetated areas (can include open water or mudflats) is high, moderate, low, or none. If you have four or more plant classes or three classes and open water, the rating is always high.</p> <div style="display: flex; justify-content: space-around; align-items: center;"> <div style="text-align: center;">  <p>None = 0 points</p> </div> <div style="text-align: center;">  <p>Low = 1 point</p> </div> <div style="text-align: center;">  <p>Moderate = 2 points</p> </div> <div style="text-align: center;">  <p>High = 3 points</p> </div> </div> <p>All three diagrams in this row are HIGH = 3 points</p>

Wetland name or number: Wetland A

H 1.5. Special habitat features:	<p>Check the habitat features that are present in the wetland. The number of checks is the number of points.</p> <p>___ Large, downed, woody debris within the wetland (> 4 in diameter and 6 ft long).</p> <p>___ Standing snags (dbh > 4 in) within the wetland</p> <p>___ Undercut banks are present for at least 6.6 ft (2 m) and/or overhanging plants extends at least 3.3 ft (1 m) over a stream (or ditch) in, or contiguous with the wetland, for at least 33 ft (10 m)</p> <p>___ Stable steep banks of fine material that might be used by beaver or muskrat for denning (> 30 degree slope) OR signs of recent beaver activity are present (cut shrubs or trees that have not yet weathered where wood is exposed)</p> <p>___ At least 1/4 ac of thin-stemmed persistent plants or woody branches are present in areas that are permanently or seasonally inundated (structures for egg-laying by amphibians)</p> <p>___ Invasive plants cover less than 25% of the wetland area in every stratum of plants (see H 1.1 for list of strata)</p>	2
Total for H 1	Add the points in the boxes above	5
<p>Rating of Site Potential If score is: 15-18 = H 7-14 = M X 0-6 = L Record the rating on the first page</p>		
H 2.0. Does the landscape have the potential to support the habitat functions of the site?		
H 2.1. Accessible habitat (include only habitat that directly abuts wetland unit).	<p>Calculate: % undisturbed habitat₁₆ + [(% moderate and low intensity land uses)/2] 0 = 16 %</p> <p>If total accessible habitat is:</p> <p>> 1/3 (33.3%) of 1 km Polygon points = 3</p> <p>20-33% of 1 km Polygon points = 2</p> <p>10-19% of 1 km Polygon points = 1</p> <p>< 10% of 1 km Polygon points = 0</p>	1
H 2.2. Undisturbed habitat in 1 km Polygon around the wetland.	<p>Calculate: % undisturbed habitat₄₆ + [(% moderate and low intensity land uses)/2] 1 = 47 %</p> <p>Undisturbed habitat > 50% of Polygon points = 3</p> <p>Undisturbed habitat 10-50% and in 1-3 patches points = 2</p> <p>Undisturbed habitat 10-50% and > 3 patches points = 1</p> <p>Undisturbed habitat < 10% of 1 km Polygon points = 0</p>	1
H 2.3. Land use intensity in 1 km Polygon; If	<p>> 50% of 1 km Polygon is high intensity land use points = (- 2)</p> <p>≤ 50% of 1 km Polygon is high intensity points = 0</p>	-2
Total for H 2	Add the points in the boxes above	0
<p>Rating of Landscape Potential If score is: 4-6 = H 1-3 = M X < 1 = L Record the rating on the first page</p>		
H 3.0. Is the habitat provided by the site valuable to society?		
H 3.1. Does the site provide habitat for species valued in laws, regulations, or policies? Choose only the highest score that applies to the wetland being rated.	<p>Site meets ANY of the following criteria:</p> <p>___ It has 3 or more priority habitats within 100 m (see next page)</p> <p>___ It provides habitat for Threatened or Endangered species (any plant or animal on the state or federal lists)</p> <p>___ It is mapped as a location for an individual WDFW priority species</p> <p>___ It is a Wetland of High Conservation Value as determined by the Department of Natural Resources</p> <p>___ It has been categorized as an important habitat site in a local or regional comprehensive plan, in a Shoreline Master Plan, or in a watershed plan</p> <p>___ Site has 1 or 2 priority habitats (listed on next page) within 100 m</p>	1
Total for H 3	Site does not meet any of the criteria above	0
<p>Rating of Value If score is: 2 = H X 1 = M 0 = L Record the rating on the first page</p>		

Wetland name or number: Wetland A

WDFW Priority Habitats

Priority habitats listed by WDFW (see complete descriptions of WDFW priority habitats, and the counties in which they can be found, in: Washington Department of Fish and Wildlife, 2008. Priority Habitat and Species List. Olympia, Washington. 177 pp. <http://wdfw.wa.gov/publications/00165/wdfw00165.pdf> or access the list from here: <http://wdfw.wa.gov/conservation/phs/list/>)

Count how many of the following priority habitats are within 330 ft (100 m) of the wetland unit: **NOTE:** *This question is independent of the land use between the wetland unit and the priority habitat.*

- **Aspen Stands:** Pure or mixed stands of aspen, greater than 1 ac (0.4 ha).
- **Biodiversity Areas and Corridors:** Areas of habitat that are relatively important to various species of native fish and wildlife (*full descriptions in WDFW PHS report*).
- **Herbaceous Balds:** Variable size patches of grass and forbs on shallow soils over bedrock.
- **Old-growth/Mature forests:** Old-growth west of Cascade crest – Stands of at least 2 tree species, forming a multi-layered canopy with occasional small openings; with at least 8 trees/ac (20 trees/ha) > 32 in (81 cm) dbh or > 200 years of age. Mature forests – Stands with average diameters exceeding 2.1 in (53 cm) dbh; crown cover may be less than 100%, decay, decadence, numbers of snags, and quantity of large downed material is generally less than that found in old-growth; 80-200 years old west of the Cascade crest.
- **Oregon White Oak:** Woodland stands of pure oak or oak/cedar associations where canopy coverage of the oak component is important (*full descriptions in WDFW PHS report p. 159 – see web link above*).
- **Riparian:** The area adjacent to aquatic systems with flowing water that contains elements of both aquatic and terrestrial ecosystems which mutually influence each other.
- **Westside Prairies:** Herbaceous, non-forested plant communities that can either take the form of a dry prairie or a wet prairie (*full descriptions in WDFW PHS report p. 161 – see web link above*).
- **Instream:** The combination of physical, biological, and chemical processes and conditions that interact to provide functional life history requirements for instream fish and wildlife resources.
- ✗ **Nearshore:** Relatively undisturbed nearshore habitats. These include Coastal Nearshore, Open Coast Nearshore, and Puget Sound Nearshore. (*full descriptions of habitats and the definition of relatively undisturbed are in WDFW report – see web link on previous page*).
- **Caves:** A naturally occurring cavity, recess, void, or system of interconnected passages under the earth in soils, rock, ice, or other geological formations and is large enough to contain a human.
- **Cliffs:** Greater than 25 ft (7.6 m) high and occurring below 5000 ft elevation.
- **Talus:** Homogenous areas of rock rubble ranging in average size 0.5 - 6.5 ft (0.15 - 2.0 m), composed of basalt, andesite, and/or sedimentary rock, including riprap slides and mine tailings. May be associated with cliffs.
- ✗ **Snags and Logs:** Trees are considered snags if they are dead or dying and exhibit sufficient decay characteristics to enable cavity excavation/use by wildlife. Priority snags have a diameter at breast height of > 20 in (51 cm) in western Washington and are > 6.5 ft (2 m) in height. Priority logs are > 12 in (30 cm) in diameter at the largest end, and > 20 ft (6 m) long.

Note: All vegetated wetlands are by definition a priority habitat but are not included in this list because they are addressed elsewhere.

Wetland name or number Wetland B

RATING SUMMARY – Western Washington

Name of wetland (or ID #): Viewcrest Wetland B Date of site visit: 6/26/20
 Rated by C. Van Slyke Trained by Ecology? Yes No Date of training 2014

HGM Class used for rating Slope Wetland has multiple HGM classes? Yes No

NOTE: Form is not complete without the figures requested (figures can be combined).

Source of base aerial photo/map Whatcom County 2017

OVERALL WETLAND CATEGORY IV (based on functions or special characteristics)

1. Category of wetland based on FUNCTIONS

Category I – Total score = 23 - 27

Category II – Total score = 20 - 22

Category III – Total score = 16 - 19

Category IV – Total score = 9 - 15

FUNCTION	Improving Water Quality	Hydrologic	Habitat
Site Potential	HO M O L ⊕	HO MO L ⊕	HO MO L ⊕
Landscape Potential	HO M ⊕ LO	HO MO L ⊕	HO MO L ⊕
Value	HO M O L ⊕	HO MO L ⊕	HO MO L ⊕
Score Based on Ratings	4	3	4
TOTAL			11

Score for each function based on three ratings (order of ratings is not important)

- 9 = H,H,H
- 8 = H,H,M
- 7 = H,H,L
- 6 = H,M,M
- 5 = H,L,L
- 4 = M,M,L
- 3 = L,L,L

2. Category based on SPECIAL CHARACTERISTICS of wetland

CHARACTERISTIC	CATEGORY
Estuarine	I II
Wetland of High Conservation Value	I
Bog	I
Mature Forest	I
Old Growth Forest	I
Coastal Lagoon	I II III IV
Interdunal	I II III IV
None of the above	<input checked="" type="checkbox"/>

Wetland Rating System for Western WA: 2014 Update
 Rating Form – Effective January 1, 2015

Wetland name or number Wetland B

Maps and figures required to answer questions correctly for Western Washington

Depressional Wetlands

Map of:	To answer questions:	Figure #
Cowardin plant classes	D 1.3, H 1.1, H 1.4	
Hydroperiods	D 1.4, H 1.2	
Location of outlet (can be added to map of hydroperiods)	D 1.1, D 4.1	
Boundary of area within 150 ft of the wetland (can be added to another figure)	D 2.2, D 5.2	
Map of the contributing basin	D 4.3, D 5.3	
1 km Polygon: Area that extends 1 km from entire wetland edge - including polygons for accessible habitat and undisturbed habitat	H 2.1, H 2.2, H 2.3	
Screen capture of map of 303(d) listed waters in basin (from Ecology website)	D 3.1, D 3.2	
Screen capture of list of TMDLs for WRIA in which unit is found (from web)	D 3.3	

Riverine Wetlands

Map of:	To answer questions:	Figure #
Cowardin plant classes	H 1.1, H 1.4	
Hydroperiods	H 1.2	
Ponded depressions	R 1.1	
Boundary of area within 150 ft of the wetland (can be added to another figure)	R 2.4	
Plant cover of trees, shrubs, and herbaceous plants	R 1.2, R 4.2	
Width of unit vs. width of stream (can be added to another figure)	R 4.1	
Map of the contributing basin	R 2.2, R 2.3, R 5.2	
1 km Polygon: Area that extends 1 km from entire wetland edge - including polygons for accessible habitat and undisturbed habitat	H 2.1, H 2.2, H 2.3	
Screen capture of map of 303(d) listed waters in basin (from Ecology website)	R 3.1	
Screen capture of list of TMDLs for WRIA in which unit is found (from web)	R 3.2, R 3.3	

Lake Fringe Wetlands

Map of:	To answer questions:	Figure #
Cowardin plant classes	L 1.1, L 4.1, H 1.1, H 1.4	
Plant cover of trees, shrubs, and herbaceous plants	L 1.2	
Boundary of area within 150 ft of the wetland (can be added to another figure)	L 2.2	
1 km Polygon: Area that extends 1 km from entire wetland edge - including polygons for accessible habitat and undisturbed habitat	H 2.1, H 2.2, H 2.3	
Screen capture of map of 303(d) listed waters in basin (from Ecology website)	L 3.1, L 3.2	
Screen capture of list of TMDLs for WRIA in which unit is found (from web)	L 3.3	

Slope Wetlands

Map of:	To answer questions:	Figure #
Cowardin plant classes	H 1.1, H 1.4	A
Hydroperiods	H 1.2	B
Plant cover of dense trees, shrubs, and herbaceous plants	S 1.3	A
Plant cover of dense, rigid trees, shrubs, and herbaceous plants (can be added to figure above)	S 4.1	A
Boundary of 150 ft buffer (can be added to another figure)	S 2.1, S 5.1	B
1 km Polygon: Area that extends 1 km from entire wetland edge - including polygons for accessible habitat and undisturbed habitat	H 2.1, H 2.2, H 2.3	C
Screen capture of map of 303(d) listed waters in basin (from Ecology website)	S 3.1, S 3.2	D
Screen capture of list of TMDLs for WRIA in which unit is found (from web)	S 3.3	D

Wetland Rating System for Western WA: 2014 Update
 Rating Form – Effective January 1, 2015

Wetland name or number Wetland B

HGM Classification of Wetlands in Western Washington

For questions 1-7, the criteria described must apply to the entire unit being rated.

If the hydrologic criteria listed in each question do not apply to the entire unit being rated, you probably have a unit with multiple HGM classes. In this case, identify which hydrologic criteria in questions 1-7 apply, and go to Question 8.

- Are the water levels in the entire unit usually controlled by tides except during floods?
NO - go to 2
YES - the wetland class is **Tidal Fringe** - go to 1.1
1.1 Is the salinity of the water during periods of annual low flow below 0.5 ppt (parts per thousand)?
NO - Saltwater Tidal Fringe (Estuarine)
YES - Freshwater Tidal Fringe
*If your wetland can be classified as a Freshwater Tidal Fringe use the forms for **Riverine** wetlands. If it is Saltwater Tidal Fringe it is an **Estuarine** wetland and is not scored. This method **cannot** be used to score functions for estuarine wetlands.*
- The entire wetland unit is flat and precipitation is the only source (>90%) of water to it. Groundwater and surface water runoff are NOT sources of water to the unit.
NO - go to 3
YES - The wetland class is **Flats**
*If your wetland can be classified as a Flats wetland, use the form for **Depressional** wetlands.*
- Does the entire wetland unit **meet all** of the following criteria?
___ The vegetated part of the wetland is on the shores of a body of permanent open water (without any plants on the surface at any time of the year) at least 20 ac (8 ha) in size;
___ At least 30% of the open water area is deeper than 6.6 ft (2 m).
NO - go to 4
YES - The wetland class is **Lake Fringe** (Lacustrine Fringe)
- Does the entire wetland unit **meet all** of the following criteria?
 The wetland is on a slope (*slope can be very gradual*).
 The water flows through the wetland in one direction (unidirectional) and usually comes from seeps. It may flow subsurface, as sheetflow, or in a swale without distinct banks,
 The water leaves the wetland **without being impounded**.
NO - go to 5
YES - The wetland class is **Slope**
NOTE: Surface water does not pond in these type of wetlands except occasionally in very small and shallow depressions or behind hummocks (depressions are usually <3 ft diameter and less than 1 ft deep).
- Does the entire wetland unit **meet all** of the following criteria?
___ The unit is in a valley, or stream channel, where it gets inundated by overbank flooding from that stream or river,
___ The overbank flooding occurs at least once every 2 years.

Wetland name or number Wetland B

NO - go to 6

NOTE: The Riverine unit can contain depressions that are filled with water when the river is not flooding

YES - The wetland class is **Riverine**

- Is the entire wetland unit in a topographic depression in which water ponds, or is saturated to the surface, at some time during the year? *This means that any outlet, if present, is higher than the interior of the wetland.*

NO - go to 7

YES - The wetland class is **Depressional**

- Is the entire wetland unit located in a very flat area with no obvious depression and no overbank flooding? The unit does not pond surface water more than a few inches. The unit seems to be maintained by high groundwater in the area. The wetland may be ditched, but has no obvious natural outlet.

NO - go to 8

YES - The wetland class is **Depressional**

- Your wetland unit seems to be difficult to classify and probably contains several different HGM classes. For example, seeps at the base of a slope may grade into a riverine floodplain, or a small stream within a Depressional wetland has a zone of flooding along its sides. **GO BACK AND IDENTIFY WHICH OF THE HYDROLOGIC REGIMES DESCRIBED IN QUESTIONS 1-7 APPLY TO DIFFERENT AREAS IN THE UNIT** (make a rough sketch to help you decide). Use the following table to identify the appropriate class to use for the rating system if you have several HGM classes present within the wetland unit being scored.

NOTE: Use this table only if the class that is recommended in the second column represents 10% or more of the total area of the wetland unit being rated. If the area of the HGM class listed in column 2 is less than 10% of the unit; classify the wetland using the class that represents more than 90% of the total area.

HGM classes within the wetland unit being rated	HGM class to use in rating
Slope + Riverine	Riverine
Slope + Depressional	Depressional
Slope + Lake Fringe	Lake Fringe
Depressional + Riverine along stream within boundary of depression	Depressional
Depressional + Lake Fringe	Depressional
Riverine + Lake Fringe	Riverine
Salt Water Tidal Fringe and any other class of freshwater wetland	Treat as ESTUARINE

If you are still unable to determine which of the above criteria apply to your wetland, or if you have more than 2 HGM classes within a wetland boundary, classify the wetland as Depressional for the rating.

Wetland name or number: Wetland B

SLOPE WETLANDS	
Water Quality Functions - Indicators that the site functions to improve water quality	
S 1.0. Does the site have the potential to improve water quality?	0
S 1.1. Characteristics of the average slope of the wetland: (a 1% slope has a 1 ft vertical drop in elevation for every 100 ft of horizontal distance) Slope is 1% or less Slope is > 1%-2% Slope is > 2%-5% Slope is greater than 5%	0
S 1.2. The soil 2 in. below the surface (or duff layer) is true clay or true organic (use NRCS definitions): Yes = 3 No = 0	0
S 1.3. Characteristics of the plants in the wetland that trap sediments and pollutants: Choose the points appropriate for the description that best fits the plants in the wetland. Dense means you have trouble seeing the soil surface (>75% cover), and uncut means not grazed or mowed and plants are higher than 6 in. Dense, uncut, herbaceous plants > 90% of the wetland area Dense, uncut, herbaceous plants > 1/2 of area Dense, woody, plants > 1/2 of area Dense, uncut, herbaceous plants > 1/4 of area Does not meet any of the criteria above for plants	2
Total for S 1	2
Rating of Site Potential If score is: <u>12 = H</u> <u>6-11 = M</u> <u>X 0-5 = L</u>	

S 2.0. Does the landscape have the potential to support the water quality function of the site?	0
S 2.1. Is > 10% of the area within 150 ft on the uphill side of the wetland in land uses that generate pollutants? Yes = 1 No = 0	0
S 2.2. Are there other sources of pollutants coming into the wetland that are not listed in question S 2.1? Other sources: _____ upslope lawns and gardens	1
Total for S 2	1
Rating of Landscape Potential If score is: <u>X 1-2 = M</u> <u>0 = L</u>	

S 3.0. Is the water quality improvement provided by the site valuable to society?	0
S 3.1. Does the wetland discharge directly (i.e., within 1 mi) to a stream, river, lake, or marine water that is on the 303(d) list? Yes = 1 No = 0	0
S 3.2. Is the wetland in a basin or sub-basin where water quality is an issue? At least one aquatic resource in the basin is on the 303(d) list. Yes = 1 No = 0	0
S 3.3. Has the site been identified in a watershed or local plan as important for maintaining water quality? Answer YES if there is a TMDL for the basin in which unit is found. Yes = 2 No = 0	0
Total for S 3	0
Rating of Value If score is: <u>2-4 = H</u> <u>1 = M</u> <u>X 0 = L</u>	

Record the rating on the first page

Wetland name or number: Wetland B

SLOPE WETLANDS	
Hydrologic Functions - Indicators that the site functions to reduce flooding and stream erosion	
S 4.0. Does the site have the potential to reduce flooding and stream erosion?	0
S 4.1. Characteristics of plants that reduce the velocity of surface flows during storms: Choose the points appropriate for the description that best fits conditions in the wetland. Stems of plants should be thick enough (usually > 1/8 in), or dense enough, to remain erect during surface flows. Dense, uncut, rigid plants cover > 90% of the area of the wetland All other conditions	0
Rating of Site Potential If score is: <u>1 = M</u> <u>X 0 = L</u>	

S 5.0. Does the landscape have the potential to support the hydrologic functions of the site?	1
S 5.1. Is more than 25% of the area within 150 ft upslope of wetland in land uses or cover that generate excess surface runoff? Yes = 1 No = 0	1
Rating of Landscape Potential If score is: <u>1 = M</u> <u>X 0 = L</u>	

S 6.0. Are the hydrologic functions provided by the site valuable to society?	0
S 6.1. Distance to the nearest areas downstream that have flooding problems: The sub-basin immediately down-gradient of site has flooding problems that result in damage to human or natural resources (e.g., houses or salmon redds) Surface flooding problems are in a sub-basin farther down-gradient No flooding problems anywhere downstream	0
S 6.2. Has the site been identified as important for flood storage or flood conveyance in a regional flood control plan? Yes = 2 No = 0	0
Total for S 6	0
Rating of Value If score is: <u>2-4 = H</u> <u>1 = M</u> <u>X 0 = L</u>	

Record the rating on the first page

NOTES and FIELD OBSERVATIONS:

Wetland name or number: Wetland B

<p style="text-align: center;">These questions apply to wetlands of all HGM classes.</p>	
<p>H 1.0. Does the site have the potential to provide habitat?</p> <p>HABITAT FUNCTIONS - Indicators that site functions to provide important habitat</p> <p>H 1.0. Does the site have the potential to provide habitat?</p> <p>H 1.1. Structure of plant community. Indicators are Cowardin classes and strata within the Forested class. Check the Cowardin plant classes in the wetland. Up to 10 patches may be combined for each class to meet the threshold of % ac or more than 10% of the unit if it is smaller than 2.5 ac. Add the number of structures checked.</p> <p>_____ Aquatic bed</p> <p>_____ Emergent</p> <p>_____ Scrub-shrub (areas where shrubs have > 30% cover)</p> <p>_____ Forested (areas where trees have > 30% cover)</p> <p>_____ If the unit has a Forested class, check if:</p> <p>_____ The Forested class has 3 out of 5 strata (canopy, sub-canopy, shrubs, herbaceous, moss/ground-cover) that each cover 20% within the Forested polygon</p> <p>H 1.2. Hydroperiods</p> <p>Check the types of water regimes (hydroperiods) present within the wetland. The water regime has to cover more than 10% of the wetland or % ac to count (see text for descriptions of hydroperiods).</p> <p>_____ Permanently flooded or inundated</p> <p>_____ Seasonally flooded or inundated</p> <p>_____ Occasionally flooded or inundated</p> <p>_____ Saturated only</p> <p>_____ Permanently flowing stream or river in, or adjacent to, the wetland</p> <p>_____ Seasonally flowing stream in, or adjacent to, the wetland</p> <p>_____ Lake Fringe wetland</p> <p>_____ Freshwater tidal wetland</p>	<p>0</p>
<p>H 1.3. Richness of plant species</p> <p>Count the number of plant species in the wetland that cover at least 10 ft.².</p> <p>Different patches of the same species can be combined to meet the size threshold and you do not have to name the species. Do not include Eurasian milfoil, reed canarygrass, purple loosestrife, Canadian thistle</p> <p>If you counted: > 19 species</p> <p>5 - 19 species</p> <p>< 5 species</p> <p>H 1.4. Interspersion of habitats</p> <p>Decide from the diagrams below whether interspersion among Cowardin plants classes (described in H 1.1), or the classes and unvegetated areas (can include open water or mudflats) is high, moderate, low, or none. If you have four or more plant classes or three classes and open water, the rating is always high.</p>	<p>1</p>
<p>H 1.5. Special habitat features:</p> <p>Check the habitat features that are present in the wetland. The number of checks is the number of points.</p> <p>_____ Large, downed, woody debris within the wetland (> 4 in diameter and 6 ft long).</p> <p>_____ Standing snags (dbh > 4 in) within the wetland</p> <p>_____ Undercut banks are present for at least 6.6 ft (2 m) and/or overhanging plants extends at least 3.3 ft (1 m) over a stream (or ditch) in, or contiguous with the wetland, for at least 33 ft (10 m)</p> <p>_____ Stable steep banks of fine material that might be used by beaver or muskrat for denning (> 30 degree slope) OR signs of recent beaver activity are present (cut shrubs or trees that have not yet weathered where wood is exposed)</p> <p>_____ At least ¼ ac of thin-stemmed persistent plants or woody branches are present in areas that are permanently or seasonally inundated (structures for egg-laying by amphibians)</p> <p>_____ Invasive plants cover less than 25% of the wetland area in every stratum of plants (see H 1.1 for list of strata)</p>	<p>0</p>

Wetland name or number: Wetland B

<p>H 1.5. Special habitat features:</p> <p>Check the habitat features that are present in the wetland. The number of checks is the number of points.</p> <p>_____ Large, downed, woody debris within the wetland (> 4 in diameter and 6 ft long).</p> <p>_____ Standing snags (dbh > 4 in) within the wetland</p> <p>_____ Undercut banks are present for at least 6.6 ft (2 m) and/or overhanging plants extends at least 3.3 ft (1 m) over a stream (or ditch) in, or contiguous with the wetland, for at least 33 ft (10 m)</p> <p>_____ Stable steep banks of fine material that might be used by beaver or muskrat for denning (> 30 degree slope) OR signs of recent beaver activity are present (cut shrubs or trees that have not yet weathered where wood is exposed)</p> <p>_____ At least ¼ ac of thin-stemmed persistent plants or woody branches are present in areas that are permanently or seasonally inundated (structures for egg-laying by amphibians)</p> <p>_____ Invasive plants cover less than 25% of the wetland area in every stratum of plants (see H 1.1 for list of strata)</p>	<p>2</p>
<p>Total for H 1</p> <p>Add the points in the boxes above</p>	<p>3</p>
<p>Rating of Site Potential If score is: 15-18 = H 7-14 = M X 0-6 = L Record the rating on the first page</p> <p>H 2.0. Does the landscape have the potential to support the habitat functions of the site?</p> <p>H 2.1. Accessible habitat (include only habitat that directly abuts wetland unit).</p> <p>Calculate: % undisturbed habitat₁₆ + [(% moderate and low intensity land uses)/2] 0 = _____ %</p> <p>If total accessible habitat is:</p> <p>> 1/3 (33.3%) of 1 km Polygon points = 3</p> <p>20-33% of 1 km Polygon points = 2</p> <p>10-19% of 1 km Polygon points = 1</p> <p>< 10% of 1 km Polygon points = 0</p> <p>H 2.2. Undisturbed habitat in 1 km Polygon around the wetland.</p> <p>Calculate: % undisturbed habitat₄₆ + [(% moderate and low intensity land uses)/2] 1 = _____ %</p> <p>Undisturbed habitat > 50% of Polygon points = 3</p> <p>Undisturbed habitat 10-50% and in 1-3 patches points = 2</p> <p>Undisturbed habitat 10-50% and > 3 patches points = 1</p> <p>Undisturbed habitat < 10% of 1 km Polygon points = 0</p> <p>H 2.3. Land use intensity in 1 km Polygon; If</p> <p>> 50% of 1 km Polygon is high intensity land use points = (- 2)</p> <p>≤ 50% of 1 km Polygon is high intensity points = 0</p>	<p>1</p> <p>-2</p> <p>0</p>
<p>Total for H 2</p> <p>Add the points in the boxes above</p>	<p>0</p>
<p>Rating of Landscape Potential If score is: 4-6 = H 1-3 = M X < 1 = L Record the rating on the first page</p> <p>H 3.0. Is the habitat provided by the site valuable to society?</p> <p>H 3.1. Does the site provide habitat for species valued in laws, regulations, or policies? Choose only the highest score that applies to the wetland being rated.</p> <p>Site meets ANY of the following criteria:</p> <p>_____ It has 3 or more priority habitats within 100 m (see next page)</p> <p>_____ It provides habitat for Threatened or Endangered species (any plant or animal on the state or federal lists)</p> <p>_____ It is mapped as a location for an individual WDFW priority species</p> <p>_____ It is a Wetland of High Conservation Value as determined by the Department of Natural Resources</p> <p>_____ It has been categorized as an important habitat site in a local or regional comprehensive plan, in a Shoreline Master Plan, or in a watershed plan</p> <p>_____ Site has 1 or 2 priority habitats (listed on next page) within 100 m</p> <p>Site does not meet any of the criteria above</p>	<p>1</p> <p>points = 1</p> <p>points = 0</p>
<p>Rating of Value If score is: 2 = H X 1 = M 0 = L Record the rating on the first page</p>	<p>0</p>

Wetland name or number: Weiland B

WDFW Priority Habitats

Priority habitats listed by WDFW (see complete descriptions of WDFW priority habitats, and the counties in which they can be found, in: Washington Department of Fish and Wildlife, 2008. Priority Habitat and Species List. Olympia, Washington. 177 pp. <http://wdfw.wa.gov/publications/00165/wdfw00165.pdf> or access the list from here: <http://wdfw.wa.gov/conservation/phs/list/>)

Count how many of the following priority habitats are within 330 ft (100 m) of the wetland unit: **NOTE:** *This question is independent of the land use between the wetland unit and the priority habitat.*

- **Aspen Stands:** Pure or mixed stands of aspen, greater than 1 ac (0.4 ha).
- **Biodiversity Areas and Corridors:** Areas of habitat that are relatively important to various species of native fish and wildlife (*full descriptions in WDFW PHS report*).
- **Herbaceous Balds:** Variable size patches of grass and forbs on shallow soils over bedrock.
- **Old-growth/Mature forests:** Old-growth west of Cascade crest – Stands of at least 2 tree species, forming a multi-layered canopy with occasional small openings; with at least 8 trees/ac (20 trees/ha) > 32 in (81 cm) dbh or > 200 years of age. Mature forests – Stands with average diameters exceeding 2.1 in (53 cm) dbh; crown cover may be less than 100%; decay, decadence, numbers of snags, and quantity of large downed material is generally less than that found in old-growth; 80-200 years old west of the Cascade crest.
- **Oregon White Oak:** Woodland stands of pure oak or oak/cedar associations where canopy coverage of the oak component is important (*full descriptions in WDFW PHS report p. 159 – see web link above*).
- **Riparian:** The area adjacent to aquatic systems with flowing water that contains elements of both aquatic and terrestrial ecosystems which mutually influence each other.
- **Westside Prairies:** Herbaceous, non-forested plant communities that can either take the form of a dry prairie or a wet prairie (*full descriptions in WDFW PHS report p. 161 – see web link above*).
- **Instream:** The combination of physical, biological, and chemical processes and conditions that interact to provide functional life history requirements for instream fish and wildlife resources.
- ✗ **Nearshore:** Relatively undisturbed nearshore habitats. These include Coastal Nearshore, Open Coast Nearshore, and Puget Sound Nearshore. (*full descriptions of habitats and the definition of relatively undisturbed are in WDFW report – see web link on previous page*).
- **Caves:** A naturally occurring cavity, recess, void, or system of interconnected passages under the earth in soils, rock, ice, or other geological formations and is large enough to contain a human.
- **Cliffs:** Greater than 25 ft (7.6 m) high and occurring below 5000 ft elevation.
- **Talus:** Homogenous areas of rock rubble ranging in average size 0.5 - 6.5 ft (0.15 - 2.0 m), composed of basalt, andesite, and/or sedimentary rock, including riprap slides and mine tailings. May be associated with cliffs.
- ✗ **Snags and Logs:** Trees are considered snags if they are dead or dying and exhibit sufficient decay characteristics to enable cavity excavation/use by wildlife. Priority snags have a diameter at breast height of > 20 in (51 cm) in western Washington and are > 6.5 ft (2 m) in height. Priority logs are > 12 in (30 cm) in diameter at the largest end, and > 20 ft (6 m) long.

Note: All vegetated wetlands are by definition a priority habitat but are not included in this list because they are addressed elsewhere.

Wetland name or number Wetland C

RATING SUMMARY – Western Washington

Name of wetland (or ID #): Viewcrest Wetland C Date of site visit: 6/26/20
 Rated by C. Van Slyke Trained by Ecology? Yes No Date of training 2014

HGM Class used for rating Slope Wetland has multiple HGM classes? Y N

NOTE: Form is not complete without the figures requested (figures can be combined).

Source of base aerial photo/map Whatcom County 2017

OVERALL WETLAND CATEGORY IV (based on functions or special characteristics)

1. Category of wetland based on FUNCTIONS

Category I – Total score = 23 - 27

Category II – Total score = 20 - 22

Category III – Total score = 16 - 19

Category IV – Total score = 9 - 15

FUNCTION	Improving Water Quality	Hydrologic	Habitat
Site Potential	HO M O L ⊕	HO MO L ⊕	HO MO L ⊕
Landscape Potential	HO M O L ⊕	HO MO L ⊕	HO MO L ⊕
Value	HO M O L ⊕	HO MO L ⊕	HO MO L ⊕
Score Based on Ratings	3	3	4
TOTAL			10

Score for each function based on three ratings (order of ratings is not important)

- 9 = H,H,H
- 8 = H,H,M
- 7 = H,H,L
- 6 = H,M,M
- 5 = H,L,L
- 4 = M,M,L
- 3 = L,L,L

2. Category based on SPECIAL CHARACTERISTICS of wetland

CHARACTERISTIC	CATEGORY
Estuarine	I II
Wetland of High Conservation Value	I
Bog	I
Mature Forest	I
Old Growth Forest	I
Coastal Lagoon	I II III IV
Interdunal	I II III IV
None of the above	<input checked="" type="checkbox"/>

Wetland Rating System for Western WA: 2014 Update
 Rating Form – Effective January 1, 2015

Wetland name or number Wetland C

Maps and figures required to answer questions correctly for Western Washington

Depressional Wetlands

Map of:	To answer questions:	Figure #
Cowardin plant classes	D 1.3, H 1.1, H 1.4	
Hydroperiods	D 1.4, H 1.2	
Location of outlet (can be added to map of hydroperiods)	D 1.1, D 4.1	
Boundary of area within 150 ft of the wetland (can be added to another figure)	D 2.2, D 5.2	
Map of the contributing basin	D 4.3, D 5.3	
1 km Polygon: Area that extends 1 km from entire wetland edge - including polygons for accessible habitat and undisturbed habitat	H 2.1, H 2.2, H 2.3	
Screen capture of map of 303(d) listed waters in basin (from Ecology website)	D 3.1, D 3.2	
Screen capture of list of TMDLs for WRIA in which unit is found (from web)	D 3.3	

Riverine Wetlands

Map of:	To answer questions:	Figure #
Cowardin plant classes	H 1.1, H 1.4	
Hydroperiods	H 1.2	
Ponded depressions	R 1.1	
Boundary of area within 150 ft of the wetland (can be added to another figure)	R 2.4	
Plant cover of trees, shrubs, and herbaceous plants	R 1.2, R 4.2	
Width of unit vs. width of stream (can be added to another figure)	R 4.1	
Map of the contributing basin	R 2.2, R 2.3, R 5.2	
1 km Polygon: Area that extends 1 km from entire wetland edge - including polygons for accessible habitat and undisturbed habitat	H 2.1, H 2.2, H 2.3	
Screen capture of map of 303(d) listed waters in basin (from Ecology website)	R 3.1	
Screen capture of list of TMDLs for WRIA in which unit is found (from web)	R 3.2, R 3.3	

Lake Fringe Wetlands

Map of:	To answer questions:	Figure #
Cowardin plant classes	L 1.1, L 4.1, H 1.1, H 1.4	
Plant cover of trees, shrubs, and herbaceous plants	L 1.2	
Boundary of area within 150 ft of the wetland (can be added to another figure)	L 2.2	
1 km Polygon: Area that extends 1 km from entire wetland edge - including polygons for accessible habitat and undisturbed habitat	H 2.1, H 2.2, H 2.3	
Screen capture of map of 303(d) listed waters in basin (from Ecology website)	L 3.1, L 3.2	
Screen capture of list of TMDLs for WRIA in which unit is found (from web)	L 3.3	

Slope Wetlands

Map of:	To answer questions:	Figure #
Cowardin plant classes	H 1.1, H 1.4	A
Hydroperiods	H 1.2	B
Plant cover of dense trees, shrubs, and herbaceous plants	S 1.3	A
Plant cover of dense, rigid trees, shrubs, and herbaceous plants (can be added to figure above)	S 4.1	A
Boundary of 150 ft buffer (can be added to another figure)	S 2.1, S 5.1	B
1 km Polygon: Area that extends 1 km from entire wetland edge - including polygons for accessible habitat and undisturbed habitat	H 2.1, H 2.2, H 2.3	C
Screen capture of map of 303(d) listed waters in basin (from Ecology website)	S 3.1, S 3.2	D
Screen capture of list of TMDLs for WRIA in which unit is found (from web)	S 3.3	D

Wetland Rating System for Western WA: 2014 Update
 Rating Form – Effective January 1, 2015

HGM Classification of Wetlands in Western Washington

For questions 1-7, the criteria described must apply to the entire unit being rated.

If the hydrologic criteria listed in each question do not apply to the entire unit being rated, you probably have a unit with multiple HGM classes. In this case, identify which hydrologic criteria in questions 1-7 apply, and go to Question 8.

1. Are the water levels in the entire unit usually controlled by tides except during floods?
 NO - go to 2
 YES - the wetland class is **Tidal Fringe** - go to 1.1

NO - Saltwater Tidal Fringe (Estuarine)
 If your wetland can be classified as a Freshwater Tidal Fringe use the forms for **Riverine** wetlands. If it is Saltwater Tidal Fringe it is an **Estuarine** wetland and is not scored. This method **cannot** be used to score functions for estuarine wetlands.

2. The entire wetland unit is flat and precipitation is the only source (>90%) of water to it. Groundwater and surface water runoff are NOT sources of water to the unit.

NO - go to 3
 YES - The wetland class is **Flats**
 If your wetland can be classified as a Flats wetland, use the form for **Depressional** wetlands.

3. Does the entire wetland unit **meet all** of the following criteria?
 ___ The vegetated part of the wetland is on the shores of a body of permanent open water (without any plants on the surface at any time of the year) at least 20 ac (8 ha) in size;
 ___ At least 30% of the open water area is deeper than 6.6 ft (2 m).

NO - go to 4
 YES - The wetland class is **Lake Fringe** (Lacustrine Fringe)
 Does the entire wetland unit **meet all** of the following criteria?
 ___ The wetland is on a slope (slope can be very gradual).
 ___ The water flows through the wetland in one direction (unidirectional) and usually comes from seeps. It may flow subsurface, as sheetflow, or in a swale without distinct banks.
 ___ The water leaves the wetland **without being impounded**.

NO - go to 5
 YES - The wetland class is **Slope**
NOTE: Surface water does not pond in these type of wetlands except occasionally in very small and shallow depressions or behind hummocks (depressions are usually <3 ft diameter and less than 1 ft deep).

5. Does the entire wetland unit **meet all** of the following criteria?
 ___ The unit is in a valley, or stream channel, where it gets inundated by overbank flooding from that stream or river,
 ___ The overbank flooding occurs at least once every 2 years.

NO - go to 6

NOTE: The Riverine unit can contain depressions that are filled with water when the river is not flooding

6. Is the entire wetland unit in a topographic depression in which water ponds, or is saturated to the surface, at some time during the year? *This means that any outlet, if present, is higher than the interior of the wetland.*

NO - go to 7

YES - The wetland class is **Depressional**

7. Is the entire wetland unit located in a very flat area with no obvious depression and no overbank flooding? The unit does not pond surface water more than a few inches. The unit seems to be maintained by high groundwater in the area. The wetland may be ditched, but has no obvious natural outlet.

NO - go to 8

YES - The wetland class is **Depressional**

8. Your wetland unit seems to be difficult to classify and probably contains several different HGM classes. For example, seeps at the base of a slope may grade into a riverine floodplain, or a small stream within a Depressional wetland has a zone of flooding along its sides. **GO BACK AND IDENTIFY WHICH OF THE HYDROLOGIC REGIMES DESCRIBED IN QUESTIONS 1-7 APPLY TO DIFFERENT AREAS IN THE UNIT** (make a rough sketch to help you decide). Use the following table to identify the appropriate class to use for the rating system if you have several HGM classes present within the wetland unit being scored.

NOTE: Use this table only if the class that is recommended in the second column represents 10% or more of the total area of the wetland unit being rated. If the area of the HGM class listed in column 2 is less than 10% of the unit; classify the wetland using the class that represents more than 90% of the total area.

HGM classes within the wetland unit being rated	HGM class to use in rating
Slope + Riverine	Riverine
Slope + Depressional	Depressional
Slope + Lake Fringe	Lake Fringe
Depressional + Riverine along stream within boundary of depression	Depressional
Depressional + Lake Fringe	Depressional
Riverine + Lake Fringe	Riverine
Salt Water Tidal Fringe and any other class of freshwater wetland	Treat as ESTUARINE

If you are still unable to determine which of the above criteria apply to your wetland, or if you have more than 2 HGM classes within a wetland boundary, classify the wetland as Depressional for the rating.

Wetland name or number: Wetland C

SLOPE WETLANDS	
Water Quality Functions - Indicators that the site functions to improve water quality	
S 1.0. Does the site have the potential to improve water quality?	0
S 1.1. Characteristics of the average slope of the wetland: (a 1% slope has a 1 ft vertical drop in elevation for every 100 ft of horizontal distance) Slope is 1% or less Slope is > 1%-2% Slope is > 2%-5% Slope is greater than 5%	0 points = 3 points = 2 points = 1 points = 0
S 1.2. The soil 2 in. below the surface (or duff layer) is true clay or true organic (use NRCS definitions): Yes = 3 No = 0	0
S 1.3. Characteristics of the plants in the wetland that trap sediments and pollutants: Choose the points appropriate for the description that best fits the plants in the wetland. Dense means you have trouble seeing the soil surface (>75% cover), and uncut means not grazed or mowed and plants are higher than 6 in. Dense, uncut, herbaceous plants > 90% of the wetland area Dense, uncut, herbaceous plants > 1/2 of area Dense, woody, plants > 1/2 of area Dense, uncut, herbaceous plants > 1/4 of area Does not meet any of the criteria above for plants	0 points = 6 points = 3 points = 2 points = 1 points = 0
Total for S 1	0
Rating of Site Potential If score is: <u>12 = H</u> <u>6-11 = M</u> <u>0-5 = L</u> Record the rating on the first page	
S 2.0. Does the landscape have the potential to support the water quality function of the site?	
S 2.1. Is > 10% of the area within 150 ft on the uphill side of the wetland in land uses that generate pollutants?	0
S 2.2. Are there other sources of pollutants coming into the wetland that are not listed in question S 2.1?	0
Other sources: _____	0
Total for S 2	0
Rating of Landscape Potential If score is: <u>1-2 = M</u> <u>0 = L</u> Record the rating on the first page	
S 3.0. Is the water quality improvement provided by the site valuable to society?	
S 3.1. Does the wetland discharge directly (i.e., within 1 mi) to a stream, river, lake, or marine water that is on the 303(d) list?	0
S 3.2. Is the wetland in a basin or sub-basin where water quality is an issue? At least one aquatic resource in the basin is on the 303(d) list.	0
S 3.3. Has the site been identified in a watershed or local plan as important for maintaining water quality? Answer YES if there is a TMDL for the basin in which unit is found.	0
Total for S 3	0
Rating of Value If score is: <u>2-4 = H</u> <u>1 = M</u> <u>0 = L</u> Record the rating on the first page	

Wetland name or number: Wetland C

SLOPE WETLANDS	
Hydrologic Functions - Indicators that the site functions to reduce flooding and stream erosion	
S 4.0. Does the site have the potential to reduce flooding and stream erosion?	0
S 4.1. Characteristics of plants that reduce the velocity of surface flows during storms: Choose the points appropriate for the description that best fits conditions in the wetland. Stems of plants should be thick enough (usually > 1/8 in), or dense enough, to remain erect during surface flows. Dense, uncut, rigid plants cover > 90% of the area of the wetland All other conditions	0 points = 1 points = 0
Rating of Site Potential If score is: <u>1 = M</u> <u>0 = L</u> Record the rating on the first page	
S 5.0. Does the landscape have the potential to support the hydrologic functions of the site?	
S 5.1. Is more than 25% of the area within 150 ft upslope of wetland in land uses or cover that generate excess surface runoff?	1
Rating of Landscape Potential If score is: <u>1 = M</u> <u>0 = L</u> Record the rating on the first page	
S 6.0. Are the hydrologic functions provided by the site valuable to society?	
S 6.1. Distance to the nearest areas downstream that have flooding problems: The sub-basin immediately down-gradient of site has flooding problems that result in damage to human or natural resources (e.g., houses or salmon redds) Surface flooding problems are in a sub-basin farther down-gradient No flooding problems anywhere downstream	0 points = 2 points = 1 points = 0
S 6.2. Has the site been identified as important for flood storage or flood conveyance in a regional flood control plan?	0
Total for S 6	0
Rating of Value If score is: <u>2-4 = H</u> <u>1 = M</u> <u>0 = L</u> Record the rating on the first page	

NOTES and FIELD OBSERVATIONS:

Wetland name or number: Wetland C

<p>These questions apply to wetlands of all HGM classes.</p> <p>HABITAT FUNCTIONS - Indicators that site functions to provide important habitat</p>	
H 1.0. Does the site have the potential to provide habitat?	0
H 1.1. Structure of plant community. Indicators are Cowardin classes and strata within the Forested class. Check the Cowardin plant classes in the wetland. Up to 10 patches may be combined for each class to meet the threshold of % ac or more than 10% of the unit if it is smaller than 2.5 ac. Add the number of structures checked.	0
<p>___ Aquatic bed</p> <p>___ Emergent</p> <p>___ Scrub-shrub (areas where shrubs have > 30% cover)</p> <p>___ Forested (areas where trees have > 30% cover)</p> <p><input checked="" type="checkbox"/> If the unit has a Forested class, check if:</p> <p>___ The Forested class has 3 out of 5 strata (canopy, sub-canopy, shrubs, herbaceous, moss/ground-cover) that each cover 20% within the Forested polygon</p>	<p>4 structures or more: points = 4</p> <p>3 structures: points = 2</p> <p>2 structures: points = 1</p> <p>1 structure: points = 0</p>
H 1.2. Hydroperiods	0
<p>Check the types of water regimes (hydroperiods) present within the wetland. The water regime has to cover more than 10% of the wetland or % ac to count (see text for descriptions of hydroperiods).</p> <p>___ Permanently flooded or inundated</p> <p>___ Seasonally flooded or inundated</p> <p>___ Occasionally flooded or inundated</p> <p><input checked="" type="checkbox"/> Saturated only</p> <p>___ Permanently flowing stream or river in, or adjacent to, the wetland</p> <p>___ Seasonally flowing stream in, or adjacent to, the wetland</p> <p>___ Lake Fringe wetland</p> <p>___ Freshwater tidal wetland</p>	<p>4 or more types present: points = 3</p> <p>3 types present: points = 2</p> <p>2 types present: points = 1</p> <p>1 type present: points = 0</p> <p>2 points</p> <p>2 points</p>
H 1.3. Richness of plant species	1
<p>Count the number of plant species in the wetland that cover at least 10 ft.².</p> <p><i>Different patches of the same species can be combined to meet the size threshold and you do not have to name the species. Do not include Eurasian milfoil, reed canarygrass, purple loosestrife, Canadian thistle</i></p> <p>If you counted: > 19 species</p> <p>5 - 19 species</p> <p>< 5 species</p>	<p>points = 2</p> <p>points = 1</p> <p>points = 0</p>
H 1.4. Interspersion of habitats	0
<p>Decide from the diagrams below whether interspersion among Cowardin plants classes (described in H 1.1), or the classes and unvegetated areas (can include open water or mudflats) is high, moderate, low, or none. If you have four or more plant classes or three classes and open water, the rating is always high.</p>	

Wetland name or number: Wetland C

H 1.5. Special habitat features:	1
<p>Check the habitat features that are present in the wetland. The number of checks is the number of points.</p> <p>___ Large, downed, woody debris within the wetland (> 4 in diameter and 6 ft long).</p> <p>___ Standing snags (dbh > 4 in) within the wetland</p> <p>___ Undercut banks are present for at least 6.6 ft (2 m) and/or overhanging plants extends at least 3.3 ft (1 m) over a stream (or ditch) in, or contiguous with the wetland, for at least 33 ft (10 m)</p> <p>___ Stable steep banks of fine material that might be used by beaver or muskrat for denning (> 30 degree slope) OR signs of recent beaver activity are present (cut shrubs or trees that have not yet weathered where wood is exposed)</p> <p>___ At least ¼ ac of thin-stemmed persistent plants or woody branches are present in areas that are permanently or seasonally inundated (structures for egg-laying by amphibians)</p> <p><input checked="" type="checkbox"/> Invasive plants cover less than 25% of the wetland area in every stratum of plants (see H 1.1 for list of strata)</p>	<p>1</p>
Total for H 1	2
<p>Add the points in the boxes above</p>	
<p>Rating of Site Potential If score is: 15-18 = H 7-14 = M X 0-6 = L Record the rating on the first page</p>	
H 2.0. Does the landscape have the potential to support the habitat functions of the site?	1
H 2.1. Accessible habitat (include only habitat that directly abuts wetland unit).	1
<p>Calculate: % undisturbed habitat₁₆ + [(% moderate and low intensity land uses)/2] 0 = 16 %</p> <p>If total accessible habitat is:</p> <p>> 1/3 (33.3%) of 1 km Polygon points = 3</p> <p>20-33% of 1 km Polygon points = 2</p> <p>10-19% of 1 km Polygon points = 1</p> <p>< 10% of 1 km Polygon points = 0</p>	<p>points = 3</p> <p>points = 2</p> <p>points = 1</p> <p>points = 0</p>
H 2.2. Undisturbed habitat in 1 km Polygon around the wetland.	1
<p>Calculate: % undisturbed habitat₄₆ + [(% moderate and low intensity land uses)/2] 1 = 47 %</p> <p>Undisturbed habitat > 50% of Polygon points = 3</p> <p>Undisturbed habitat 10-50% and in 1-3 patches points = 2</p> <p>Undisturbed habitat 10-50% and > 3 patches points = 1</p> <p>Undisturbed habitat < 10% of 1 km Polygon points = 0</p>	<p>points = 3</p> <p>points = 2</p> <p>points = 1</p> <p>points = 0</p>
H 2.3. Land use intensity in 1 km Polygon; If	-2
<p>> 50% of 1 km Polygon is high intensity land use points = (- 2)</p> <p>≤ 50% of 1 km Polygon is high intensity points = 0</p>	<p>points = (- 2)</p> <p>points = 0</p>
Total for H 2	0
<p>Add the points in the boxes above</p>	
<p>Rating of Landscape Potential If score is: 4-6 = H 1-3 = M X < 1 = L Record the rating on the first page</p>	
H 3.0. Is the habitat provided by the site valuable to society?	1
H 3.1. Does the site provide habitat for species valued in laws, regulations, or policies? Choose only the highest score that applies to the wetland being rated.	1
<p>Site meets ANY of the following criteria:</p> <p>___ It has 3 or more priority habitats within 100 m (see next page)</p> <p>___ It provides habitat for Threatened or Endangered species (any plant or animal on the state or federal lists)</p> <p>___ It is mapped as a location for an individual WDFW priority species</p> <p>___ It is a Wetland of High Conservation Value as determined by the Department of Natural Resources</p> <p>___ It has been categorized as an important habitat site in a local or regional comprehensive plan, in a Shoreline Master Plan, or in a watershed plan</p> <p>___ Site has 1 or 2 priority habitats (listed on next page) within 100 m</p>	<p>points = 2</p> <p>points = 1</p> <p>points = 0</p>
<p>Site does not meet any of the criteria above</p>	
<p>Rating of Value If score is: 2 = H X 1 = M 0 = L Record the rating on the first page</p>	

Wetland name or number: Wetland C

WDFW Priority Habitats

Priority habitats listed by WDFW (see complete descriptions of WDFW priority habitats, and the counties in which they can be found, in: Washington Department of Fish and Wildlife, 2008. Priority Habitat and Species List. Olympia, Washington. 177 pp. <http://wdfw.wa.gov/publications/00165/wdfw00165.pdf> or access the list from here: <http://wdfw.wa.gov/conservation/phbs/list/>)

Count how many of the following priority habitats are within 330 ft (100 m) of the wetland unit: **NOTE:** *This question is independent of the land use between the wetland unit and the priority habitat.*

- **Aspen Stands:** Pure or mixed stands of aspen, greater than 1 ac (0.4 ha).
- **Biodiversity Areas and Corridors:** Areas of habitat that are relatively important to various species of native fish and wildlife (*full descriptions in WDFW PHS report*).
- **Herbaceous Balds:** Variable size patches of grass and forbs on shallow soils over bedrock.
- **Old-growth/Mature forests:** Old-growth west of Cascade crest – Stands of at least 2 tree species, forming a multi-layered canopy with occasional small openings; with at least 8 trees/ac (20 trees/ha) > 32 in (81 cm) dbh or > 200 years of age. Mature forests – Stands with average diameters exceeding 2.1 in (53 cm) dbh; crown cover may be less than 100%; decay, decadence, numbers of snags, and quantity of large downed material is generally less than that found in old-growth; 80-200 years old west of the Cascade crest.
- **Oregon White Oak:** Woodland stands of pure oak or oak/cedar associations where canopy coverage of the oak component is important (*full descriptions in WDFW PHS report p. 159 – see web link above*).
- **Riparian:** The area adjacent to aquatic systems with flowing water that contains elements of both aquatic and terrestrial ecosystems which mutually influence each other.
- **Westside Prairies:** Herbaceous, non-forested plant communities that can either take the form of a dry prairie or a wet prairie (*full descriptions in WDFW PHS report p. 161 – see web link above*).
- **Instream:** The combination of physical, biological, and chemical processes and conditions that interact to provide functional life history requirements for instream fish and wildlife resources.
- ✗ **Nearshore:** Relatively undisturbed nearshore habitats. These include Coastal Nearshore, Open Coast Nearshore, and Puget Sound Nearshore. (*full descriptions of habitats and the definition of relatively undisturbed are in WDFW report – see web link on previous page*).
- **Caves:** A naturally occurring cavity, recess, void, or system of interconnected passages under the earth in soils, rock, ice, or other geological formations and is large enough to contain a human.
- **Cliffs:** Greater than 25 ft (7.6 m) high and occurring below 5000 ft elevation.
- **Talus:** Homogenous areas of rock rubble ranging in average size 0.5 - 6.5 ft (0.15 - 2.0 m), composed of basalt, andesite, and/or sedimentary rock, including riprap slides and mine tailings. May be associated with cliffs.
- ✗ **Snags and Logs:** Trees are considered snags if they are dead or dying and exhibit sufficient decay characteristics to enable cavity excavation/use by wildlife. Priority snags have a diameter at breast height of > 20 in (51 cm) in western Washington and are > 6.5 ft (2 m) in height. Priority logs are > 12 in (30 cm) in diameter at the largest end, and > 20 ft (6 m) long.

Note: All vegetated wetlands are by definition a priority habitat but are not included in this list because they are addressed elsewhere.

Wetland name or number Wetland D

RATING SUMMARY – Western Washington

Name of wetland (or ID #): Viewcrest Wetland D Date of site visit: 6/26/20
 Rated by C. Van Slyke Trained by Ecology? Yes No Date of training 2014

HGM Class used for rating Slope Wetland has multiple HGM classes? Y N

NOTE: Form is not complete without the figures requested (figures can be combined).

Source of base aerial photo/map Whatcom County 2017

OVERALL WETLAND CATEGORY IV (based on functions or special characteristics)

1. Category of wetland based on FUNCTIONS

Category I – Total score = 23 - 27

Category II – Total score = 20 - 22

Category III – Total score = 16 - 19

Category IV – Total score = 9 - 15

FUNCTION	Improving		Hydrologic	Habitat				
	Water Quality	Water Quality						
Site Potential	HO	MOL	HO	MO L	HO	MO	L	⊗
Landscape Potential	HO	MOL	HO	MO L	HO	MO	L	⊗
Value	HO	MOL	HO	MO L	HO	MO	L	⊗
Score Based on Ratings	3	3	3	4				
TOTAL					10			

Score for each function based on three ratings (order of ratings is not important)

- 9 = H,H,H
- 8 = H,H,M
- 7 = H,H,L
- 6 = H,M,M
- 5 = H,L,L
- 4 = M,M,L
- 3 = L,L,L

2. Category based on SPECIAL CHARACTERISTICS of wetland

CHARACTERISTIC	CATEGORY
Estuarine	I II
Wetland of High Conservation Value	I
Bog	I
Mature Forest	I
Old Growth Forest	I
Coastal Lagoon	I II
Interdunal	I II III IV
None of the above	<input checked="" type="checkbox"/>

Wetland Rating System for Western WA: 2014 Update
 Rating Form – Effective January 1, 2015

Wetland name or number Wetland D

Maps and figures required to answer questions correctly for Western Washington

Depressional Wetlands

Map of:	To answer questions:	Figure #
Cowardin plant classes	D 1.3, H 1.1, H 1.4	
Hydroperiods	D 1.4, H 1.2	
Location of outlet (can be added to map of hydroperiods)	D 1.1, D 4.1	
Boundary of area within 150 ft of the wetland (can be added to another figure)	D 2.2, D 5.2	
Map of the contributing basin	D 4.3, D 5.3	
1 km Polygon: Area that extends 1 km from entire wetland edge - including polygons for accessible habitat and undisturbed habitat	H 2.1, H 2.2, H 2.3	
Screen capture of map of 303(c) listed waters in basin (from Ecology website)	D 3.1, D 3.2	
Screen capture of list of TMDLs for WRIA in which unit is found (from web)	D 3.3	

Riverine Wetlands

Map of:	To answer questions:	Figure #
Cowardin plant classes	H 1.1, H 1.4	
Hydroperiods	H 1.2	
Ponded depressions	R 1.1	
Boundary of area within 150 ft of the wetland (can be added to another figure)	R 2.4	
Plant cover of trees, shrubs, and herbaceous plants	R 1.2, R 4.2	
Width of unit vs. width of stream (can be added to another figure)	R 4.1	
Map of the contributing basin	R 2.2, R 2.3, R 5.2	
1 km Polygon: Area that extends 1 km from entire wetland edge - including polygons for accessible habitat and undisturbed habitat	H 2.1, H 2.2, H 2.3	
Screen capture of map of 303(c) listed waters in basin (from Ecology website)	R 3.1	
Screen capture of list of TMDLs for WRIA in which unit is found (from web)	R 3.2, R 3.3	

Lake Fringe Wetlands

Map of:	To answer questions:	Figure #
Cowardin plant classes	L 1.1, L 4.1, H 1.1, H 1.4	
Plant cover of trees, shrubs, and herbaceous plants	L 1.2	
Boundary of area within 150 ft of the wetland (can be added to another figure)	L 2.2	
1 km Polygon: Area that extends 1 km from entire wetland edge - including polygons for accessible habitat and undisturbed habitat	H 2.1, H 2.2, H 2.3	
Screen capture of map of 303(c) listed waters in basin (from Ecology website)	L 3.1, L 3.2	
Screen capture of list of TMDLs for WRIA in which unit is found (from web)	L 3.3	

Slope Wetlands

Map of:	To answer questions:	Figure #
Cowardin plant classes	H 1.1, H 1.4	A
Hydroperiods	H 1.2	B
Plant cover of dense trees, shrubs, and herbaceous plants	S 1.3	A
Plant cover of dense, rigid trees, shrubs, and herbaceous plants (can be added to figure above)	S 4.1	A
Boundary of 150 ft buffer (can be added to another figure)	S 2.1, S 5.1	B
1 km Polygon: Area that extends 1 km from entire wetland edge - including polygons for accessible habitat and undisturbed habitat	H 2.1, H 2.2, H 2.3	C
Screen capture of map of 303(c) listed waters in basin (from Ecology website)	S 3.1, S 3.2	D
Screen capture of list of TMDLs for WRIA in which unit is found (from web)	S 3.3	D

Wetland Rating System for Western WA: 2014 Update
 Rating Form – Effective January 1, 2015

HGM Classification of Wetlands in Western Washington

For questions 1-7, the criteria described must apply to the entire unit being rated. If the hydrologic criteria listed in each question do not apply to the entire unit being rated, you probably have a unit with multiple HGM classes. In this case, identify which hydrologic criteria in questions 1-7 apply, and go to Question 8.

- Are the water levels in the entire unit usually controlled by tides except during floods?
 - NO - go to 2
 - YES - the wetland class is **Tidal Fringe** - go to 1.1
- 1.1 Is the salinity of the water during periods of annual low flow below 0.5 ppt (parts per thousand)?
 - NO - **Saltwater Tidal Fringe (Estuarine)**
If your wetland can be classified as a Freshwater Tidal Fringe use the forms for **Riverine wetlands**. If it is Saltwater Tidal Fringe it is an **Estuarine wetland** and is not scored. This method **cannot** be used to score functions for estuarine wetlands.
 - YES - **Freshwater Tidal Fringe**
- Does the entire wetland unit **meet all** of the following criteria?
 - The vegetated part of the wetland is on the shores of a body of permanent open water (without any plants on the surface at any time of the year) at least 20 ac (8 ha) in size;
 - At least 30% of the open water area is deeper than 6.6 ft (2 m).

- NO - go to 3
If your wetland can be classified as a Flats wetland, use the form for **Depressional wetlands**.
 - YES - The wetland class is **Flats**
- Does the entire wetland unit **meet all** of the following criteria?
 - The wetland is on a slope (slope can be very gradual).
 - The water flows through the wetland in one direction (unidirectional) and usually comes from seeps. It may flow subsurface, as sheetflow, or in a swale without distinct banks,
 - The water leaves the wetland **without being impounded**.

- NO - go to 4
YES - The wetland class is **Lake Fringe** (Lacustrine Fringe)
 - Does the entire wetland unit **meet all** of the following criteria?
 - The wetland is on a slope (slope can be very gradual).
 - The water flows through the wetland in one direction (unidirectional) and usually comes from seeps. It may flow subsurface, as sheetflow, or in a swale without distinct banks,
 - The water leaves the wetland **without being impounded**.
- NO - go to 5
YES - The wetland class is **Slope**
 - NOTE: Surface water does not pond in these type of wetlands except occasionally in very small and shallow depressions or behind hummocks (depressions are usually <3 ft diameter and less than 1 ft deep).

- Does the entire wetland unit **meet all** of the following criteria?
 - The unit is in a valley, or stream channel, where it gets inundated by overbank flooding from that stream or river,
 - The overbank flooding occurs at least once every 2 years.

NO - go to 6

NOTE: The Riverine unit can contain depressions that are filled with water when the river is not flooding

- Is the entire wetland unit in a topographic depression in which water ponds, or is saturated to the surface, at some time during the year? This means that any outlet, if present, is higher than the interior of the wetland.
 - NO - go to 7
 - YES - The wetland class is **Depressional**
- Is the entire wetland unit located in a very flat area with no obvious depression and no overbank flooding? The unit does not pond surface water more than a few inches. The unit seems to be maintained by high groundwater in the area. The wetland may be ditched, but has no obvious natural outlet.
 - NO - go to 8
 - YES - The wetland class is **Depressional**
- Your wetland unit seems to be difficult to classify and probably contains several different HGM classes. For example, seeps at the base of a slope may grade into a riverine floodplain, or a small stream within a Depressional wetland has a zone of flooding along its sides. GO BACK AND IDENTIFY WHICH OF THE HYDROLOGIC REGIMES DESCRIBED IN QUESTIONS 1-7 APPLY TO DIFFERENT AREAS IN THE UNIT (make a rough sketch to help you decide). Use the following table to identify the appropriate class to use for the rating system if you have several HGM classes present within the wetland unit being scored.

NOTE: Use this table only if the class that is recommended in the second column represents 10% or more of the total area of the wetland unit being rated. If the area of the HGM class listed in column 2 is less than 10% of the unit; classify the wetland using the class that represents more than 90% of the total area.

HGM classes within the wetland unit being rated	HGM class to use in rating
Slope + Riverine	Riverine
Slope + Depressional	Depressional
Slope + Lake Fringe	Lake Fringe
Depressional + Riverine along stream within boundary of depression	Depressional
Depressional + Lake Fringe	Depressional
Riverine + Lake Fringe	Riverine
Salt Water Tidal Fringe and any other class of freshwater wetland	Treat as ESTUARINE

If you are still unable to determine which of the above criteria apply to your wetland, or if you have more than 2 HGM classes within a wetland boundary, classify the wetland as Depressional for the rating.

Wetland name or number: Wetland D

SLOPE WETLANDS	
Water Quality Functions - Indicators that the site functions to improve water quality	
S 1.0. Does the site have the potential to improve water quality?	0
S 1.1. Characteristics of the average slope of the wetland: (a 1% slope has a 1 ft vertical drop in elevation for every 100 ft of horizontal distance)	
Slope is 1% or less	points = 3
Slope is > 1%-2%	points = 2
Slope is > 2%-5%	points = 1
Slope is greater than 5%	points = 0
S 1.2. The soil 2 in below the surface (or duff layer) is true clay or true organic (use NRCS definitions): Yes = 3 No = 0	0
S 1.3. Characteristics of the plants in the wetland that trap sediments and pollutants: Choose the points appropriate for the description that best fits the plants in the wetland. Dense means you have trouble seeing the soil surface (>75% cover), and uncut means not grazed or mowed and plants are higher than 6 in.	
Dense, uncut, herbaceous plants > 90% of the wetland area	points = 6
Dense, uncut, herbaceous plants > 1/2 of area	points = 3
Dense, woody, plants > 1/2 of area	points = 2
Dense, uncut, herbaceous plants > 1/4 of area	points = 1
Does not meet any of the criteria above for plants	points = 0
Total for S 1	1
Rating of Site Potential If score is: 12 = H 6-11 = M 0-5 = L Record the rating on the first page	

S 2.0. Does the landscape have the potential to support the water quality function of the site?	0
S 2.1. Is > 10% of the area within 150 ft on the uphill side of the wetland in land uses that generate pollutants?	0
Yes = 1 No = 0	
S 2.2. Are there other sources of pollutants coming into the wetland that are not listed in question S 2.1?	0
Other sources _____	
Yes = 1 No = 0	
Total for S 2	0
Rating of Landscape Potential If score is: 3-2 = M 0 = L Record the rating on the first page	

S 3.0. Is the water quality improvement provided by the site valuable to society?	0
S 3.1. Does the wetland discharge directly (i.e., within 1 mi) to a stream, river, lake, or marine water that is on the 303(d) list?	0
Yes = 1 No = 0	
S 3.2. Is the wetland in a basin or sub-basin where water quality is an issue? At least one aquatic resource in the basin is on the 303(d) list.	0
Yes = 1 No = 0	
S 3.3. Has the site been identified in a watershed or local plan as important for maintaining water quality? Answer YES if there is a TMDL for the basin in which unit is found.	0
Yes = 2 No = 0	
Total for S 3	0
Rating of Value If score is: 2-4 = H 1 = M 0 = L Record the rating on the first page	

Wetland name or number: Wetland D

SLOPE WETLANDS	
Hydrologic Functions - Indicators that the site functions to reduce flooding and stream erosion	
S 4.0. Does the site have the potential to reduce flooding and stream erosion?	0
S 4.1. Characteristics of plants that reduce the velocity of surface flows during storms: Choose the points appropriate for the description that best fits conditions in the wetland. Stems of plants should be thick enough (usually > 1/8 in), or dense enough, to remain erect during surface flows.	
Dense, uncut, rigid plants cover > 90% of the area of the wetland	points = 1
All other conditions	points = 0
Rating of Site Potential If score is: 1 = M 0 = L Record the rating on the first page	

S 5.0. Does the landscape have the potential to support the hydrologic functions of the site?	1
S 5.1. Is more than 25% of the area within 150 ft upslope of wetland in land uses or cover that generate excess surface runoff?	0
Yes = 1 No = 0	
Rating of Landscape Potential If score is: 1 = M 0 = L Record the rating on the first page	

S 6.0. Are the hydrologic functions provided by the site valuable to society?	0
S 6.1. Distance to the nearest areas downstream that have flooding problems: The sub-basin immediately down-gradient of site has flooding problems that result in damage to human or natural resources (e.g., houses or salmon redds)	0
Surface flooding problems are in a sub-basin farther down-gradient	points = 2
No flooding problems anywhere downstream	points = 1
S 6.2. Has the site been identified as important for flood storage or flood conveyance in a regional flood control plan?	0
Yes = 2 No = 0	
Total for S 6	0
Rating of Value If score is: 2-4 = H 1 = M 0 = L Record the rating on the first page	

NOTES and FIELD OBSERVATIONS:

Wetland name or number: Wetland D

<p style="text-align: center;">These questions apply to wetlands of all HGM classes.</p> <p>HABITAT FUNCTIONS - Indicators that site functions to provide important habitat</p>	
H 1.0. Does the site have the potential to provide habitat?	1
H 1.1. Structure of plant community. Indicators are Cowardin classes and strata within the Forested class. Check the Cowardin plant classes in the wetland. Up to 10 patches may be combined for each class to meet the threshold of % ac or more than 10% of the unit if it is smaller than 2.5 ac. Add the number of structures checked.	1
<p>___ Aquatic bed</p> <p><input checked="" type="checkbox"/> Emergent</p> <p><input checked="" type="checkbox"/> Scrub-shrub (areas where shrubs have > 30% cover)</p> <p>___ Forested (areas where trees have > 30% cover)</p> <p>___ If the unit has a Forested class, check if:</p> <p>___ The Forested class has 3 out of 5 strata (canopy, sub-canopy, shrubs, herbaceous, moss/ground-cover) that each cover 20% within the Forested polygon</p>	<p>4 structures or more: points = 4</p> <p>3 structures: points = 2</p> <p>2 structures: points = 1</p> <p>1 structure: points = 0</p>
H 1.2. Hydroperiods	1
<p>Check the types of water regimes (hydroperiods) present within the wetland. The water regime has to cover more than 10% of the wetland or % ac to count (see text for descriptions of hydroperiods).</p> <p><input checked="" type="checkbox"/> Permanently flooded or inundated</p> <p><input checked="" type="checkbox"/> Seasonally flooded or inundated</p> <p><input checked="" type="checkbox"/> Occasionally flooded or inundated</p> <p><input checked="" type="checkbox"/> Saturated only</p> <p>___ Permanently flowing stream or river in, or adjacent to, the wetland</p> <p>___ Seasonally flowing stream in, or adjacent to, the wetland</p> <p>___ Lake Fringe wetland</p> <p>___ Freshwater tidal wetland</p>	<p>4 or more types present: points = 3</p> <p>3 types present: points = 2</p> <p>2 types present: points = 1</p> <p>1 type present: points = 0</p> <p>2 points</p> <p>2 points</p>
H 1.3. Richness of plant species	1
<p>Count the number of plant species in the wetland that cover at least 10 ft.².</p> <p><i>Different patches of the same species can be combined to meet the size threshold and you do not have to name the species. Do not include Eurasian miffoil, reed canarygrass, purple loosestrife, Canadian thistle</i></p> <p>If you counted: > 19 species</p> <p>5 - 19 species</p> <p>< 5 species</p>	<p>points = 2</p> <p>points = 1</p> <p>points = 0</p>
H 1.4. Interspersion of habitats	1
<p>Decide from the diagrams below whether interspersion among Cowardin plants classes (described in H 1.1), or the classes and unvegetated areas (can include open water or mudflats) is high, moderate, low, or none. If you have four or more plant classes or three classes and open water, the rating is always high.</p>	<p style="text-align: center;"> </p> <p>None = 0 points</p> <p>Low = 1 point</p> <p>Moderate = 2 points</p> <p>High = 3 points</p>

Wetland name or number: Wetland D

H 1.5. Special habitat features:	1
<p>Check the habitat features that are present in the wetland. The number of checks is the number of points.</p> <p><input checked="" type="checkbox"/> Large, downed, woody debris within the wetland (> 4 in diameter and 6 ft long).</p> <p>___ Standing snags (dbh > 4 in) within the wetland</p> <p>___ Undercut banks are present for at least 6.6 ft (2 m) and/or overhanging plants extends at least 3.3 ft (1 m) over a stream (or ditch) in, or contiguous with the wetland, for at least 33 ft (10 m)</p> <p>___ Stable steep banks of fine material that might be used by beaver or muskrat for denning (> 30 degree slope) OR signs of recent beaver activity are present (cut shrubs or trees that have not yet weathered where wood is exposed)</p> <p>___ At least 1/4 ac of thin-stemmed persistent plants or woody branches are present in areas that are permanently or seasonally inundated (structures for egg-laying by amphibians)</p> <p>___ Invasive plants cover less than 25% of the wetland area in every stratum of plants (see H 1.1 for list of strata)</p>	<p>Add the points in the boxes above</p>
Total for H 1	5
<p>Rating of Site Potential If score is: 15-18 = H 7-14 = M X 0-6 = L Record the rating on the first page</p>	
H 2.0. Does the landscape have the potential to support the habitat functions of the site?	1
H 2.1. Accessible habitat (include only habitat that directly abuts wetland unit).	1
<p>Calculate: % undisturbed habitat $\frac{16}{20} + [(\% moderate and low intensity land uses) / 2] \times 0.16 = \underline{\quad} \%$</p> <p>If total accessible habitat is:</p> <p>> 1/3 (33.3%) of 1 km Polygon points = 3</p> <p>20-33% of 1 km Polygon points = 2</p> <p>10-19% of 1 km Polygon points = 1</p> <p>< 10% of 1 km Polygon points = 0</p>	<p>points = 3</p> <p>points = 2</p> <p>points = 1</p> <p>points = 0</p>
H 2.2. Undisturbed habitat in 1 km Polygon around the wetland.	1
<p>Calculate: % undisturbed habitat $\frac{48}{50} + [(\% moderate and low intensity land uses) / 2] \times 0.47 = \underline{\quad} \%$</p> <p>Undisturbed habitat > 50% of Polygon points = 3</p> <p>Undisturbed habitat 10-50% and in 1-3 patches points = 2</p> <p>Undisturbed habitat 10-50% and > 3 patches points = 1</p> <p>Undisturbed habitat < 10% of 1 km Polygon points = 0</p>	<p>points = 3</p> <p>points = 2</p> <p>points = 1</p> <p>points = 0</p>
H 2.3. Land use intensity in 1 km Polygon: If	-2
<p>> 50% of 1 km Polygon is high intensity land use points = (- 2)</p> <p>≤ 50% of 1 km Polygon is high intensity points = 0</p>	<p>points = (- 2)</p> <p>points = 0</p>
Total for H 2	0
<p>Rating of Landscape Potential If score is: 4-6 = H 1-3 = M X < 1 = L Record the rating on the first page</p>	
H 3.0. Is the habitat provided by the site valuable to society?	1
H 3.1. Does the site provide habitat for species valued in laws, regulations, or policies? Choose only the highest score that applies to the wetland being rated.	1
<p>Site meets ANY of the following criteria:</p> <p>___ It has 3 or more priority habitats within 100 m (see next page)</p> <p>___ It provides habitat for Threatened or Endangered species (any plant or animal on the state or federal lists)</p> <p>___ It is mapped as a location for an individual WDFW priority species</p> <p>___ It is a Wetland of High Conservation Value as determined by the Department of Natural Resources</p> <p>___ It has been categorized as an important habitat site in a local or regional comprehensive plan, in a Shoreline Master Plan, or in a watershed plan</p> <p>___ Site has 1 or 2 priority habitats (listed on next page) within 100 m</p>	<p>points = 2</p> <p>points = 1</p> <p>points = 0</p>
<p>Site does not meet any of the criteria above</p> <p>Rating of Value If score is: 2 = H X 1 = M 0 = L Record the rating on the first page</p>	

Wetland name or number Wetland D

WDFW Priority Habitats





Priority habitats listed by WDFW (see complete descriptions of WDFW priority habitats, and the counties in which they can be found, in: Washington Department of Fish and Wildlife. 2008. Priority Habitat and Species List. Olympia, Washington. 177 pp. <http://wdfw.wa.gov/publications/00165/wdvw00165.pdf> or access the list from here: <http://wdfw.wa.gov/conservation/dhs/list/>)

Count how many of the following priority habitats are within 330 ft (100 m) of the wetland unit: **NOTE:** *This question is independent of the land use between the wetland unit and the priority habitat.*

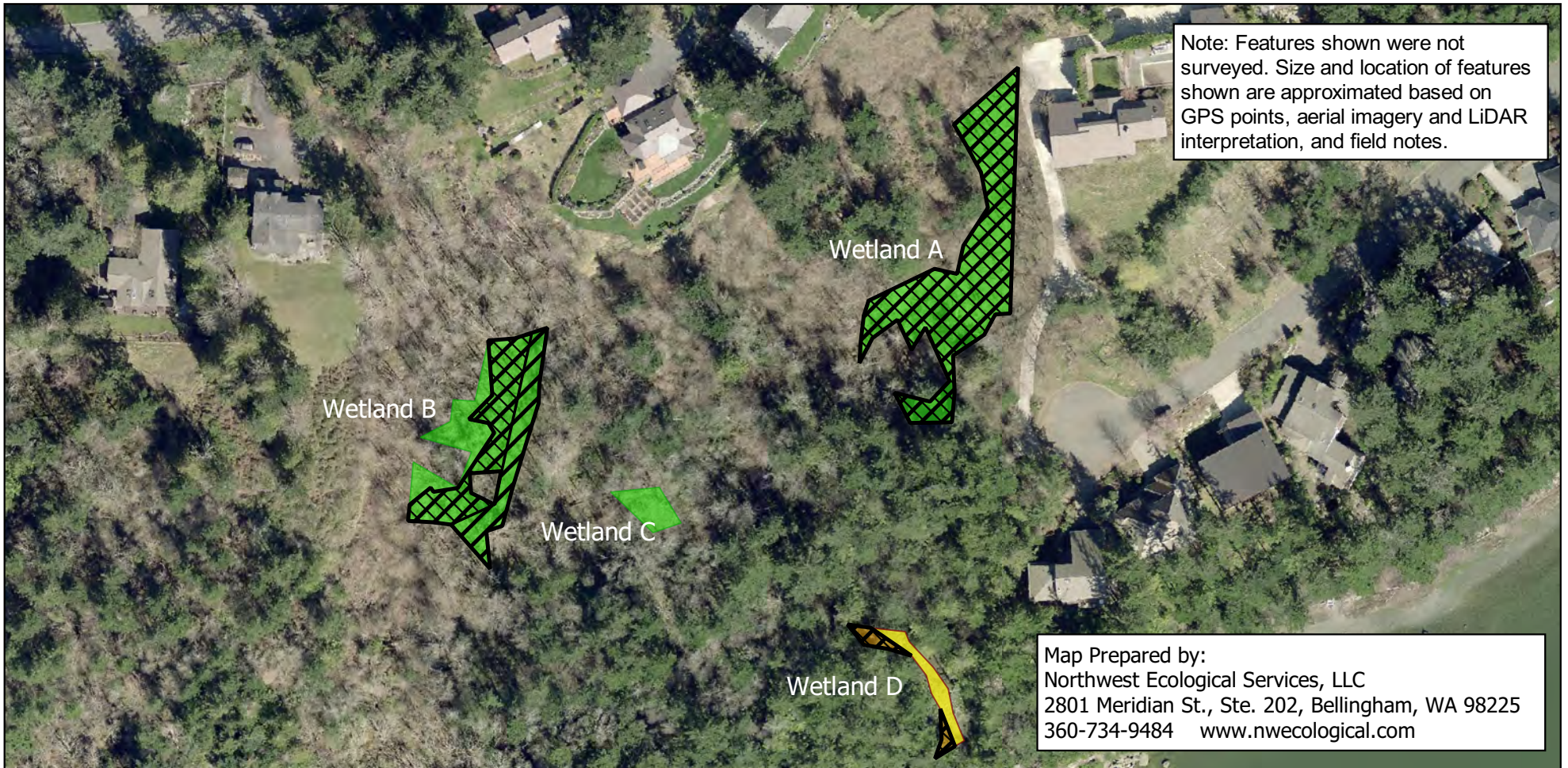
- **Aspen Stands:** Pure or mixed stands of aspen greater than 1 ac (0.4 ha).
- **Biodiversity Areas and Corridors:** Areas of habitat that are relatively important to various species of native fish and wildlife (*full descriptions in WDFW PHS report*).
- **Herbaceous Balds:** Variable size patches of grass and forbs on shallow soils over bedrock.
- **Old-growth/Mature forests: Old-growth west of Cascade crest** – Stands of at least 2 tree species, forming a multi-layered canopy with occasional small openings; with at least 8 trees/ac (20 trees/ha) > 32 in (81 cm) dbh or > 200 years of age. Mature forests – Stands with average diameters exceeding 21 in (53 cm) dbh; crown cover may be less than 100%, decay, decadence, numbers of snags, and quantity of large downed material is generally less than that found in old-growth; 80-200 years old west of the Cascade crest.
- **Oregon White Oak:** Woodland stands of pure oak or oak/conifer associations where canopy coverage of the oak component is important (*full descriptions in WDFW PHS report p. 158 – see web link above*).
- **Riparian:** The area adjacent to aquatic systems with flowing water that contains elements of both aquatic and terrestrial ecosystems which mutually influence each other.
- **Westside Prairies:** Herbaceous, non-forested plant communities that can either take the form of a dry prairie or a wet prairie (*full descriptions in WDFW PHS report p. 161 – see web link above*).
- **Instream:** The combination of physical, biological, and chemical processes and conditions that interact to provide functional life history requirements for instream fish and wildlife resources.
- ✗ **Nearshore:** Relatively undisturbed nearshore habitats. These include Coastal Nearshore, Open Coast Nearshore, and Puget Sound Nearshore. (*full descriptions of habitats and the definition of relatively undisturbed are in WDFW report – see web link on previous page*).
- **Caves:** A naturally occurring cavity, recess, void, or system of interconnected passages under the earth in soils, rock, ice, or other geological formations and is large enough to contain a human.
- **Cliffs:** Greater than 25 ft (7.6 m) high and occurring below 5000 ft elevation.
- **Talus:** Homogenous areas of rock rubble ranging in average size 0.5 - 6.5 ft (0.15 - 2.0 m), composed of basalt, andesite, and/or sedimentary rock, including riprap slides and mine tailings. May be associated with cliffs.
- ✗ **Snags and Logs:** Trees are considered snags if they are dead or dying and exhibit sufficient decay characteristics to enable cavity excavation/use by wildlife. Priority snags have a diameter at breast height of > 20 in (51 cm) in western Washington and are > 6.5 ft (2 m) in height. Priority logs are > 12 in (30 cm) in diameter at the largest end, and > 20 ft (6 m) long.

Note: All vegetated wetlands are by definition a priority habitat but are not included in this list because they are addressed elsewhere.



 Forested	 Scrub Shrub	 Dense Veg
 Emergent	 Rigid Veg	

Aerial Photo: Whatcom County 2019

0 50 100 150 200 ft



	<p>Wetland Rating Figure: Vegetation Map</p> <p>Viewcrest Wetland Delineation Update</p>	<p>Attachment A</p> <p>OCT 2021</p>
---	---	---

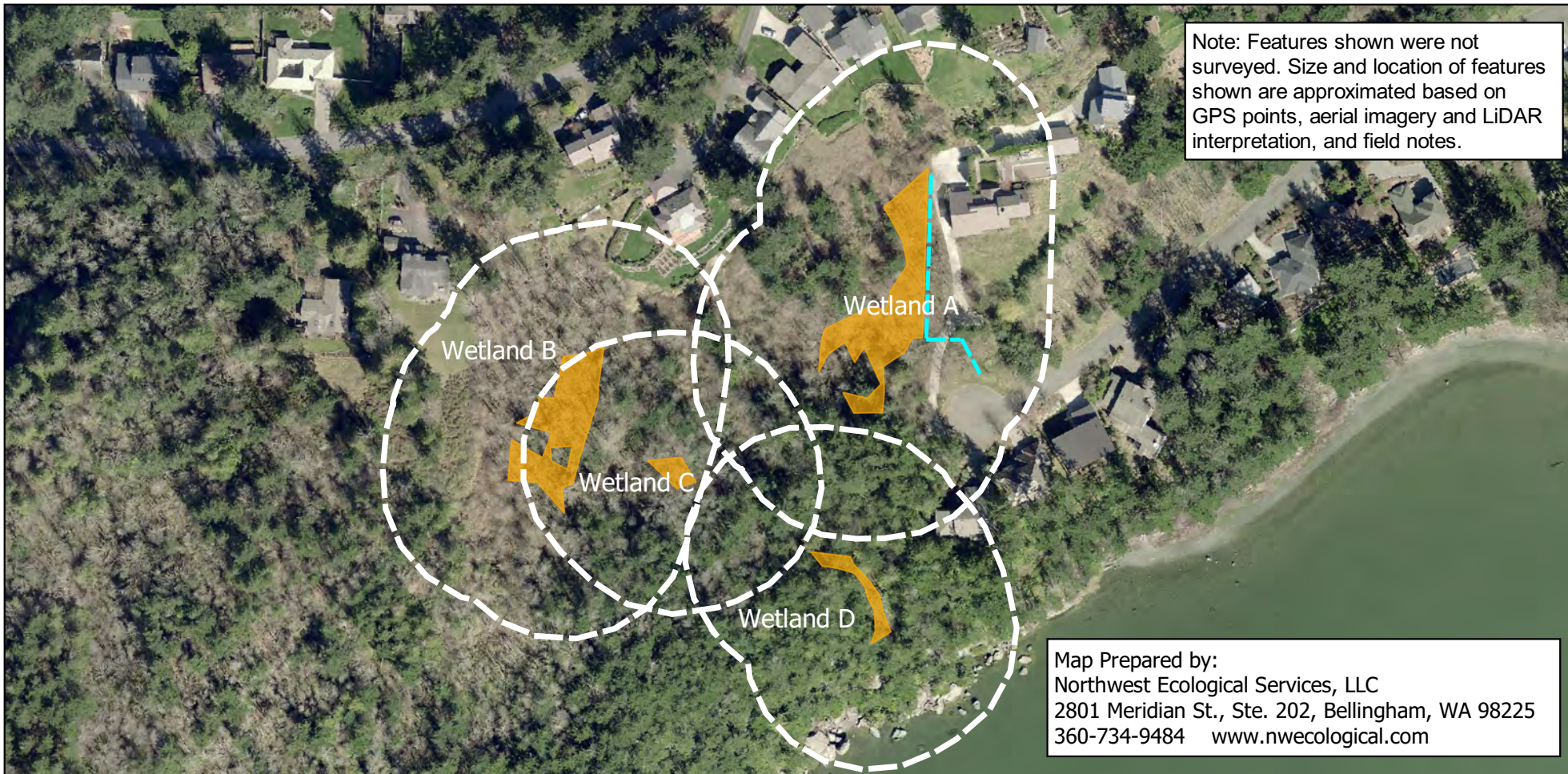

Note: Features shown were not surveyed. Size and location of features shown are approximated based on GPS points, aerial imagery and LiDAR interpretation, and field notes.

Map Prepared by:
 Northwest Ecological Services, LLC
 2801 Meridian St., Ste. 202, Bellingham, WA 98225
 360-734-9484 www.nwecological.com

150ft Polygon Saturated Ditch

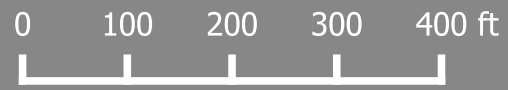

Aerial Photo: Whatcom County 2019

<p>ECOLOGICAL NORTHWEST</p> 	<p>Wetland Rating Figure: Hydrology Map</p> <p>Viewcrest Wetland Delineation Update</p>	<p>Attachment B</p> <p>OCT 2021</p>
--	--	---



Note: Features shown were not surveyed. Size and location of features shown are approximated based on GPS points, aerial imagery and LiDAR interpretation, and field notes.

Map Prepared by:
 Northwest Ecological Services, LLC
 2801 Meridian St., Ste. 202, Bellingham, WA 98225
 360-734-9484 www.nwecological.com

- Site Wetlands
- Moderate/Low Intensity
- 1km Polygon
- Undisturbed

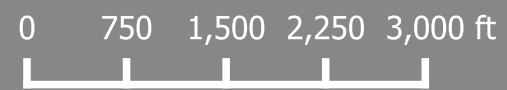

Aerial Photo: Whatcom County 2019

<p>NORTHWEST </p>	<p>Wetland Rating Figure: Land Use Map</p> <p>Viewcrest Wetland Delineation Update</p>	<p>Attachment C</p> <p>OCT 2021</p>
-------------------------------	---	---

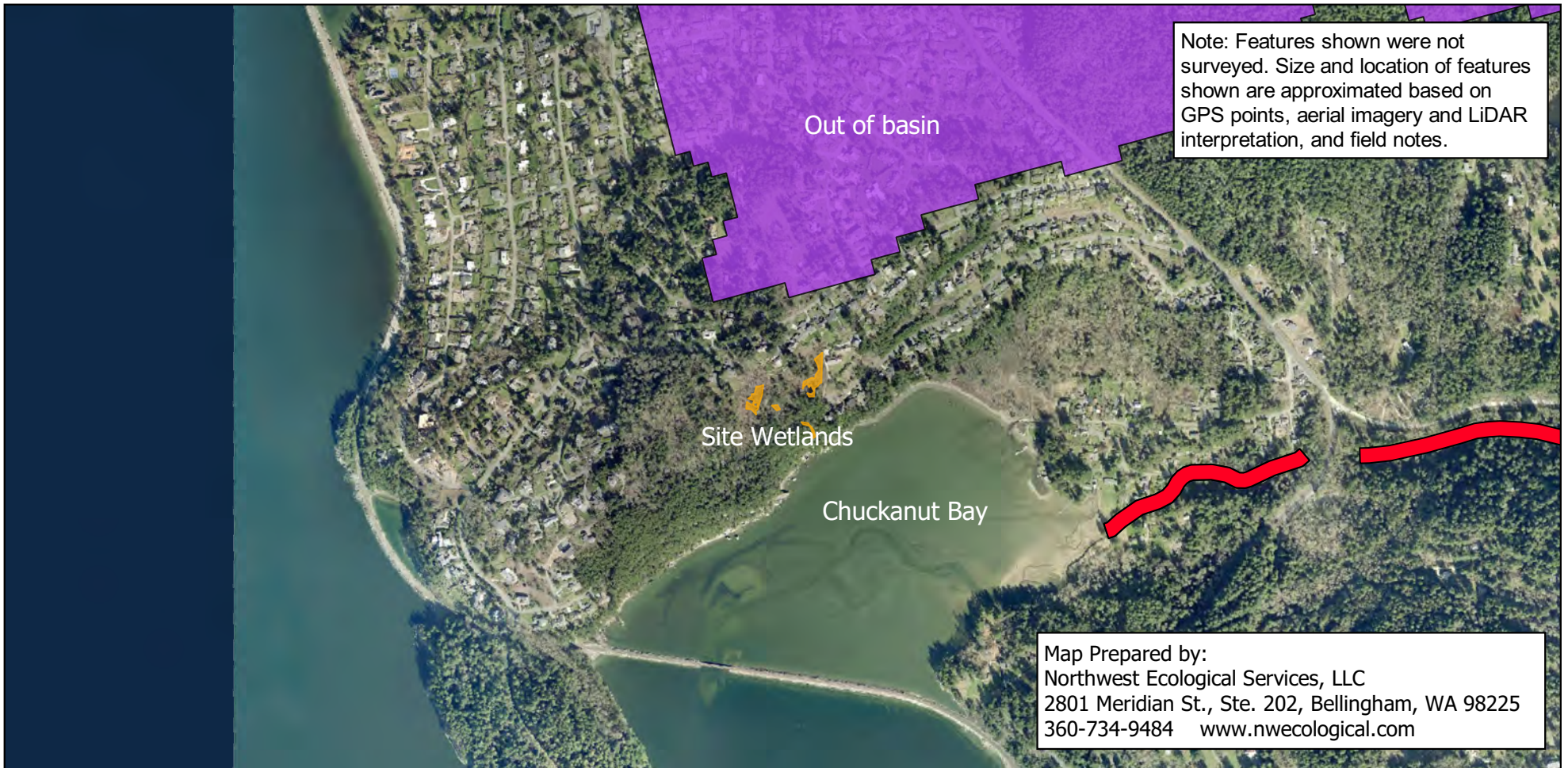

 Site Wetlands

TMDL Boundaries

 303d Waters

 Approved

 In Development

1 in = 1,000

0 500 1,000 1,500 2,000 ft



Aerial Photo: Whatcom County 2019

	<p style="text-align: center;">Wetland Rating Figure: Water Quality Map</p> <p style="text-align: center;">Viewcrest Wetland Delineation Update</p>	<p style="text-align: center;">Attachment D</p> <p style="text-align: center;">OCT 2021</p>
---	--	--

8.7 GULD FOR MODULAR WETLAND SYSTEM



August 2021

**GENERAL USE LEVEL DESIGNATION FOR BASIC (TSS)
ENHANCED AND PHOSPHORUS TREATMENT**

For

MWS-Linear Modular Wetland

Ecology's Decision

Based on Modular Wetland Systems, Inc, application submissions, including the Technical Evaluation Report, dated April 1, 2014, Ecology hereby issues the following use level designation:

1. General Use Level Designation (GULD) for the MWS-Linear Modular Wetland Stormwater Treatment System for Basic, Phosphorus, and Enhanced treatment
 - Sized at a hydraulic loading rate of:
 - 1 gallon per minute (gpm) per square foot (sq ft) of Wetland Cell Surface Area
 - Prefilter box (approved at either 22 inches or 33 inches tall)
 - 3.0 gpm/sq ft of prefilter box surface area for moderate pollutant loading rates (low to medium density residential basins).
 - 2.1 gpm/sq ft of prefilter box surface area for high pollutant loading rates (commercial and industrial basins).
2. Ecology approves the MWS – Linear Modular Wetland Stormwater Treatment System units for Basic, Phosphorus, and Enhanced treatment at the hydraulic loading rate listed above. Designers shall calculate the water quality design flow rates using the following procedures:
 - Western Washington: For treatment installed upstream of detention or retention, the water quality design flow rate is the peak 15-minute water quality treatment design flow rate as calculated using the latest version of the Western Washington Hydrology Model or other Ecology- approved continuous runoff model.

- Eastern Washington: For treatment installed upstream of detention or retention, the water quality design flow rate is the peak 15-minute water quality treatment design flow rate as calculated using one of the three methods described in Chapter 2.2.5 of the Stormwater Management Manual for Eastern Washington (SWMMEW) or local manual.
 - Entire State: For treatment installed downstream of detention, the water quality treatment design flow rate is the full 2-year release rate of the detention facility.
3. These use level designations have no expiration date but may be amended or revoked by Ecology, and are subject to the conditions specified below.

Ecology's Conditions of Use

Applicants shall comply with the following conditions:

- 1) Design, assemble, install, operate, and maintain the MWS – Linear Modular Wetland Stormwater Treatment System units, in accordance with Modular Wetland Systems, Inc. applicable manuals and documents and the Ecology Decision.
- 2) Each site plan must undergo Modular Wetland Systems, Inc. review and approval before site installation. This ensures that site grading and slope are appropriate for use of a MWS – Linear Modular Wetland Stormwater Treatment System unit.
- 3) MSW – Linear Modular Wetland Stormwater Treatment System media shall conform to the specifications submitted to and approved by Ecology.
- 4) The applicant tested the MWS – Linear Modular Wetland Stormwater Treatment System with an external bypass weir. This weir limited the depth of water flowing through the media, and therefore the active treatment area, to below the root zone of the plants. This GULD applies to MWS – Linear Modular Wetland Stormwater Treatment Systems whether plants are included in the final product or not.
- 5) Maintenance: The required maintenance interval for stormwater treatment devices is often dependent upon the degree of pollutant loading from a particular drainage basin. Therefore, Ecology does not endorse or recommend a “one size fits all” maintenance cycle for a particular model/size of stormwater treatment technology.
 - Typically, Modular Wetland Systems, Inc. designs MWS – Linear Modular Wetland systems for a target prefilter media life of 6 to 12 months.
 - Indications of the need for maintenance include effluent flow decreasing to below the design flow rate or decrease in treatment below required levels.
 - Owners/operators must inspect MWS – Linear Modular Wetland systems for a minimum of twelve months from the start of post-construction operation to determine site-specific maintenance schedules and requirements. You must conduct inspections monthly during the wet season, and every other month during the dry season (According to the SWMMWW, the wet season in western Washington is October 1 to April

30. According to the SWMMEW, the wet season in eastern Washington is October 1 to June 30). After the first year of operation, owners/operators must conduct inspections based on the findings during the first year of inspections.

- Conduct inspections by qualified personnel, follow manufacturer's guidelines, and use methods capable fo determining either a decrease in treated effluent flowrate and/or a decrease in pollutant removal ability.
- When inspections are performed, the following findings typically serve as maintenance triggers:
 - Standing water remains in the vault between rain events, or
 - Bypass occurs during storms smaller than the design storm.
 - If excessive floatables (trash and debris) are present (but no standing water or excessive sedimentation), perform a minor maintenance consisting of gross solids removal, not prefilter media replacement.
 - Additional data collection will be used to create a correlation between pretreatment chamber sediment depth and pre-filter clogging (see *Issues to be Addressed by the Company* section below)

6) Discharges from the MWS – Linear Modular Wetland Stormwater Treatment System units shall not cause or contribute to water quality standards violations in receiving waters.

Applicant: Modular Wetland Systems, Inc.

Applicant's Address: 5796 Armada Drive, Suite 250
Carlsbad, CA 92008

Application Documents:

Original Application for Conditional Use Level Designation, Modular Wetland System, Linear Stormwater Filtration System Modular Wetland Systems, Inc., January 2011

Quality Assurance Project Plan: Modular Wetland System – Linear Treatment System Performance Monitoring Project, draft, January 2011

Revised Application for Conditional Use Level Designation, Modular Wetland System, Linear Stormwater Filtration System Modular Wetland Systems, Inc., May 2011

Memorandum: Modular Wetland System-Linear GULD Application Supplementary Data, April 2014

Applicant's Use Level Request:

- General Use Level Designation as a Basic, Enhanced, and Phosphorus treatment device in accordance with Ecology's Guidance for Evaluating Emerging Stormwater Treatment Technologies Technology Assessment Protocol – Ecology (TAPE) January 2011 Revision.

Applicant's Performance Claims:

- The MWS – Linear Modular wetland is capable of removing a minimum of 80-percent of TSS from stormwater with influent concentrations between 100 and 200 mg/L.
- The MWS – Linear Modular wetland is capable of removing a minimum of 50-percent of total phosphorus from stormwater with influent concentrations between 0.1 and 0.5 mg/L.
- The MWS – Linear Modular wetland is capable of removing a minimum 30-percent of dissolved copper from stormwater with influent concentrations between 0.005 and 0.020 mg/L.
- The MWS – Linear Modular wetland is capable of removing a minimum 60-percent of dissolved zinc from stormwater with influent concentrations between 0.02 and 0.30 mg/L.

Ecology's Recommendations:

- Modular Wetland System, Inc. has shown Ecology, through laboratory and field-testing, that the MWS – Linear Modular Wetland Stormwater Treatment System filter system is capable of attaining Ecology's Basic, Phosphorus, and Enhanced treatment goals.

Findings of Fact:

Laboratory Testing

The MWS-Linear Modular wetland has the:

- Capability to remove 99 percent of total suspended solids (using Sil-Co-Sil 106) in a quarter-scale model with influent concentrations of 270 mg/L.
- Capability to remove 91 percent of total suspended solids (using Sil-Co-Sil 106) in laboratory conditions with influent concentrations of 84.6 mg/L at a flow rate of 3.0 gpm per square foot of media.
- Capability to remove 93 percent of dissolved Copper in a quarter-scale model with influent concentrations of 0.757 mg/L.
- Capability to remove 79 percent of dissolved Copper in laboratory conditions with influent concentrations of 0.567 mg/L at a flow rate of 3.0 gpm per square foot of media.

- Capability to remove 80.5-percent of dissolved Zinc in a quarter-scale model with influent concentrations of 0.95 mg/L at a flow rate of 3.0 gpm per square foot of media.
- Capability to remove 78-percent of dissolved Zinc in laboratory conditions with influent concentrations of 0.75 mg/L at a flow rate of 3.0 gpm per square foot of media.

Field Testing

- Modular Wetland Systems, Inc. conducted monitoring of an MWS-Linear (Model # MWS-L-4-13) from April 2012 through May 2013, at a transportation maintenance facility in Portland, Oregon. The manufacturer collected flow-weighted composite samples of the system's influent and effluent during 28 separate storm events. The system treated approximately 75 percent of the runoff from 53.5 inches of rainfall during the monitoring period. The applicant sized the system at 1 gpm/sq ft. (wetland media) and 3gpm/sq ft. (prefilter).
- Influent TSS concentrations for qualifying sampled storm events ranged from 20 to 339 mg/L. Average TSS removal for influent concentrations greater than 100 mg/L (n=7) averaged 85 percent. For influent concentrations in the range of 20-100 mg/L (n=18), the upper 95 percent confidence interval about the mean effluent concentration was 12.8 mg/L.
- Total phosphorus removal for 17 events with influent TP concentrations in the range of 0.1 to 0.5 mg/L averaged 65 percent. A bootstrap estimate of the lower 95 percent confidence limit (LCL95) of the mean total phosphorus reduction was 58 percent.
- The lower 95 percent confidence limit of the mean percent removal was 60.5 percent for dissolved zinc for influent concentrations in the range of 0.02 to 0.3 mg/L (n=11). The lower 95 percent confidence limit of the mean percent removal was 32.5 percent for dissolved copper for influent concentrations in the range of 0.005 to 0.02 mg/L (n=14) at flow rates up to 28 gpm (design flow rate 41 gpm). Laboratory test data augmented the data set, showing dissolved copper removal at the design flow rate of 41 gpm (93 percent reduction in influent dissolved copper of 0.757 mg/L).

Issues to be addressed by the Company:

1. Modular Wetland Systems, Inc. should collect maintenance and inspection data for the first year on all installations in the Northwest in order to assess standard maintenance requirements for various land uses in the region. Modular Wetland Systems, Inc. should use these data to establish required maintenance cycles.
2. Modular Wetland Systems, Inc. should collect pre-treatment chamber sediment depth data for the first year of operation for all installations in the Northwest. Modular Wetland Systems, Inc. will use these data to create a correlation between sediment depth and pre-filter clogging.

Technology Description:

Download at <http://www.modularwetlands.com/>

Contact Information:

Applicant: Zach Kent
 BioClean A Forterra Company
 5796 Armada Drive, Suite 250
 Carlsbad, CA 92008
 zach.kent@forterrabp.com

Applicant website: <http://www.modularwetlands.com/>

Ecology web link: <http://www.ecy.wa.gov/programs/wg/stormwater/newtech/index.html>

Ecology: Douglas C. Howie,
 P.E. Department of
 Ecology Water
 Quality Program
 (360) 870-0983
douglas.howie@ecy.wa.gov

Revision History

Date	Revision
June 2011	Original use-level-designation document
September 2012	Revised dates for TER and expiration
January 2013	Modified Design Storm Description, added Revision Table, added maintenance discussion, modified format in accordance with Ecology standard
December 2013	Updated name of Applicant
April 2014	Approved GULD designation for Basic, Phosphorus, and Enhanced treatment
December 2015	Updated GULD to document the acceptance of MWS – Linear Modular Wetland installations with or without the inclusion of plants
July 2017	Revised Manufacturer Contact Information (name, address, and email)
December 2019	Revised Manufacturer Contact Address
July 2021	Added additional prefilter sized at 33 inches
August 2021	Changed “Prefilter” to “Prefilter box”